

# APPENDIX 28E

## UNITIZATION PROCEDURES FOR BOXED AMMUNITION AND COMPONENTS ON 4-WAY ENTRY PALLETS

CARTRIDGE, 60MM, PACKED 16 PER WIREBOUND,  
BOX, UNITIZED 24 BOXES PER 40" X 48" PALLET;  
APPROX BOX SIZE 14-15/16" L X 13-3/16" W X  
14-5/8" H

NOTICE: THIS APPENDIX CANNOT STAND ALONE BUT MUST BE USED IN CONJUNCTION WITH  
THE BASIC UNITIZATION PROCEDURES DRAWING 19-48-4116-20PA1002.

DISTRIBUTION STATEMENT A.

APPROVED FOR PUBLIC RELEASE:  
DISTRIBUTION IS UNLIMITED.

U.S. ARMY MATERIEL COMMAND DRAWING			
APPROVED, U.S. ARMY INDUSTRIAL OPERATIONS COMMAND <i>NLH</i>  <i>David A. Piskovik</i> <i>David E. Otaekuba</i> AMSTA-AR-ESK                      AMSIO-TMJ	DRAFTSMAN	BETTY J. KUNDERT	
	ENGINEER	SANDRA M. SCHULTZ	
	SUPPLY ENGINEERING DIVISION	TRANSPORTATION ENGINEERING DIVISION	VALIDATION ENGINEERING DIVISION
	<i>T. J. Michel</i>	<i>W. Erenick</i>	<i>M. Becker</i>
APPROVED BY ORDER OF COMMANDING GENERAL, U.S. ARMY MATERIEL COMMAND  <i>Arthur J. Rosavalle</i>	LOGISTICS ENGINEERING OFFICE		
	<i>William J. Ernst</i>		
	JULY 1979		
U.S. ARMY DEFENSE AMMUNITION CENTER AND SCHOOL	CLASS	DIVISION	DRAWING
REVISION NO. 1      MARCH 1996	19	48	4116/ 28E
SEE THE REVISION LISTING ON PAGE 2			FILE 20PA 1002

DO NOT SCALE

PALLET UNIT DATA				
ITEMS INCLUDED		HAZARD CLASS AND DIVISION ●		APPROX WEIGHT LBS
NSN	DODIC	OD CLASS	COMP GROUP	
1310-00-134-8359	B632	(08)1.2	E	2,152
01-240-9255	B632	(08)1.2	E	2,152

- HAZARD CLASSIFICATION DATA CONTAINED IN THE ABOVE CHART IS FOR GUIDANCE AND INFORMATIONAL PURPOSES ONLY. VERIFICATION OF THE SPECIFIED DATA SHOULD BE MADE BY CONSULTING THE MOST RECENT JOINT HAZARD CLASSIFICATION SYSTEM LISTING OR OTHER APPROVED LISTING(S).

#### REVISION

REVISION NO. 1, DATED MARCH 1996, CONSISTS OF:

1. DELETING ITEMS BY NATIONAL STOCK NUMBER FROM "PALLET UNIT DATA" CHART.
2. ADDING ITEM BY NATIONAL STOCK NUMBER TO "PALLET UNIT DATA" CHART.
3. CHANGE HEIGHT OF BOX.
4. DELETED GENERAL NOTE RELATING TO STRAP CUTTER. ADDED GENERAL NOTE RELATING TO CHAMFERS AND STRAP SLOTS ON THE PALLET. RE-LETTERED OTHER GENERAL NOTES.

**GENERAL NOTES**

- A. THIS APPENDIX CANNOT STAND ALONE BUT MUST BE USED IN CONJUNCTION WITH THE BASIC UNITIZATION PROCEDURES DRAWING 19-48-4116-20PA1002. TO PRODUCE AN APPROVED UNIT LOAD, ALL PERTINENT PROCEDURES, SPECIFICATIONS AND CRITERIA SET FORTH WITHIN THE BASIC DRAWING WILL APPLY TO THE PROCEDURES DELINEATED IN THIS APPENDIX. ANY EXCEPTIONS TO THE BASIC PROCEDURES ARE SPECIFIED IN THIS APPENDIX.
- B. DIMENSIONS, CUBE AND WEIGHT OF A PALLET UNIT WILL VARY SLIGHTLY DEPENDING UPON THE ACTUAL DIMENSIONS OF THE BOXES AND THE WEIGHT OF THE SPECIFIC ITEM BEING UNITIZED.
- C. INSTALL EACH HORIZONTAL STRAP TO ENIRCLE A LAYER OF BOXES ON THE PALLET. NOTE THAT THE STRAPS WILL BE LOCATED AS SHOWN, NEAR THE TOP OF EACH LAYER. HORIZONTAL STRAPS MUST BE TENSIONED AND SEALED PRIOR TO APPLICATION OF TIEDOWN STRAPS.
- D. INSTALL EACH TIEDOWN STRAP TO PASS UNDER THE TOP DECK BOARDS OF THE PALLET AND TO BE LOCATED AS SHOWN. TIEDOWN STRAPS WILL NOT BE APPLIED UNTIL THE HORIZONTAL STRAPS HAVE BEEN TENSIONED AND SEALED.
- E. THE FOLLOWING AMC DRAWINGS ARE APPLICABLE FOR OUTLOADING AND STORAGE OF THE ITEMS COVERED BY THIS APPENDIX.
  - CARLOADING - - - - 19-48-4115-5PA1002
  - TRUCKLOADING - - - - 19-48-4117-11PA1003
  - STORAGE - - - - - 19-48-4118-1-2-3-4-14-22PA1002
  - END OPENING ISO
  - CONTAINER - - - - - 19-48-4153-15PA1002
  - MILVAN - - - - - 19-48-4166-15PA1003
  - SIDE OPENING ISO
  - CONTAINER - - - - - 19-48-4267-15PA1009
- F. IF ITEMS COVERED HEREIN ARE UNITIZED PRIOR TO ISSUANCE OF THIS APPENDIX, THE BOXES NEED NOT BE REUNITIZED SOLELY TO CONFORM TO THIS APPENDIX.
- G. THE UNITIZATION PROCEDURES DEPICTED HEREIN MAY ALSO BE USED FOR UNITIZING 60MM CARTRIDGES WHEN IDENTIFIED BY DIFFERENT NATIONAL STOCK NUMBERS (NSN) THAN WHAT IS SHOWN ON PAGE 2, PROVIDED THE BOX PACK DOES NOT VARY FROM WHAT IS DELINEATED HEREIN. THE EXPLOSIVE CLASSIFICATION OF OTHER ITEMS MAY BE DIFFERENT THAN WHAT IS SHOWN.
- H. POSITION THE EIGHT OUTBOARD BOXES ON THE 48" SIDES OF THE UNIT WITH THE TOPS OUTWARD.
- J. THE STYLE 1 PALLET DELINEATED IN THE DETAIL AT LEFT NEED NOT HAVE CHAMFERS OR STRAP SLOTS AS SPECIFIED WITHIN MILITARY SPECIFICATION MIL-P-15011 WHEN USED FOR THE UNITIZATION OF ITEMS COVERED BY THIS APPENDIX.

TIEDOWN STRAP, 3/4" X .035" OR .031" X 13'-5" LONG STEEL STRAPPING (4 REQD). SEE GENERAL NOTE "D" AT RIGHT.

HORIZONTAL STRAP, 3/4" X .035" OR .031" X 17'-2" LONG STEEL STRAPPING (2 REQD). SEE GENERAL NOTE "C" AT RIGHT.

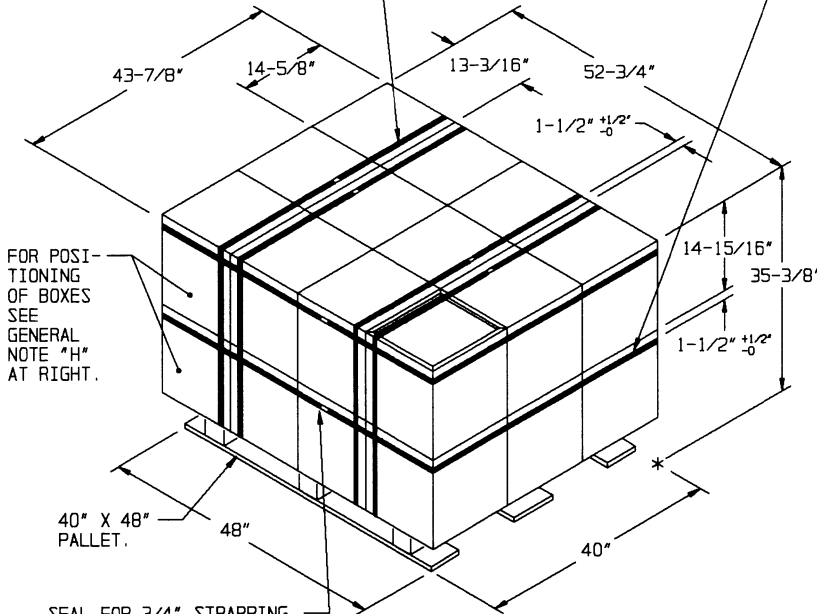

FOR POSITIONING OF BOXES SEE GENERAL NOTE "H" AT RIGHT.

SEAL FOR 3/4" STRAPPING (6 REQD, 1 PER STRAP). CRIMP EACH SEAL WITH TWO PAIR OF NOTCHES.

**PALLET UNIT**

SEE GENERAL NOTE "B" AT RIGHT.

24 BOXES OF 60MM CARTRIDGE (16 PER BOX) AT 86 LBS	-----	2,064 LBS (APPROX)
DUNNAGE	-----	8 LBS
PALLET	-----	80 LBS

TOTAL WEIGHT	-----	2,152 LBS (APPROX)
CUBE	-----	47.4 CU FT (APPROX)

**BILL OF MATERIAL**

PALLET, 40" X 48"	-----	1 REQD	-----	80 LBS
STEEL STRAPPING, 3/4"	-----	88' REQD	-----	7.86 LBS
SEAL FOR 3/4" STRAPPING	-----	6 REQD	-----	NIL

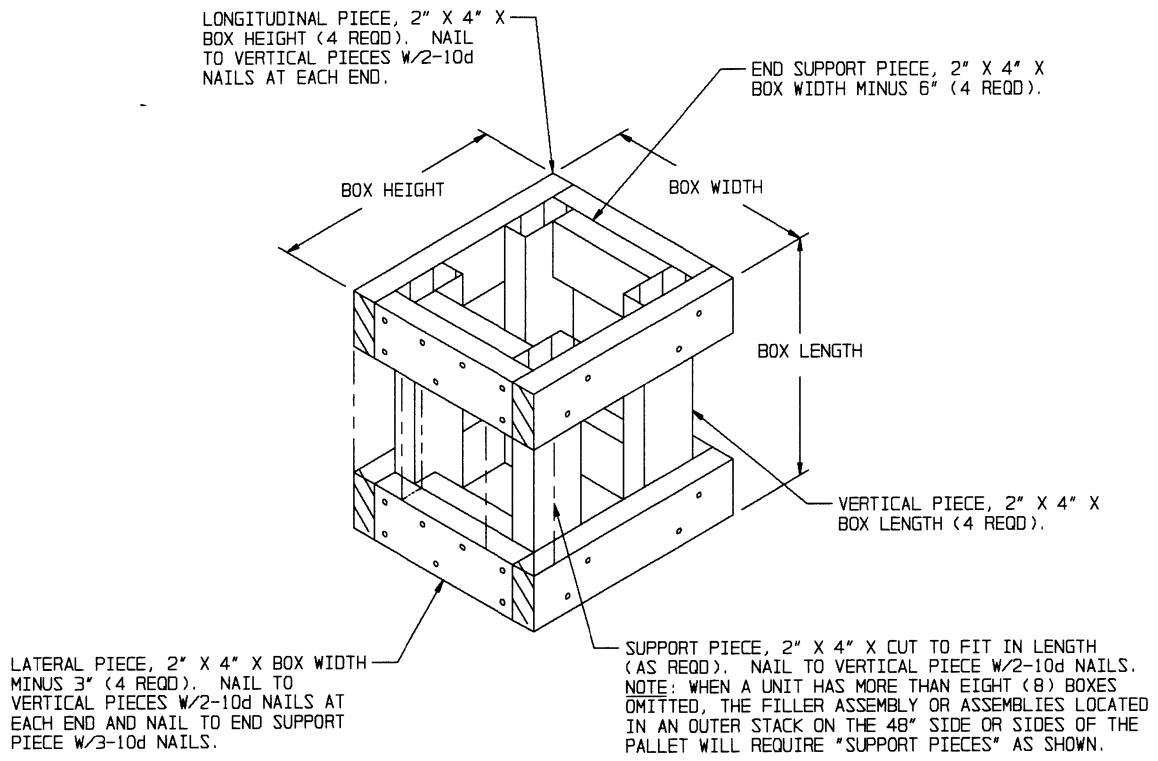

**FILLER ASSEMBLY**  
 (FOR MINUS ONE BOX)