

APPENDIX 28A

UNITIZATION PROCEDURES FOR BOXED AMMUNITION AND COMPO- NENTS ON 4-WAY ENTRY PALLETS

**CARTRIDGE, 60MM, PACKED 10 PER WOODEN BOX,
UNITIZED 40 BOXES PER 40" X 48" PALLET;
APPROX BOX SIZE 17-9/16" L X 12-1/8" W X 8-7/32" H**

NOTICE: THIS APPENDIX CANNOT STAND ALONE BUT MUST BE USED IN CONJUNCTION WITH THE BASIC UNITIZATION PROCEDURES DRAWING 19-48-4116-20PA1002.

DISTRIBUTION STATEMENT A:

APPROVED FOR PUBLIC RELEASE
DISTRIBUTION IS UNLIMITED.

U.S. ARMY MATERIEL COMMAND DRAWING

<p style="font-size: small;">APPROVED, U.S. ARMY FIELD SUPPORT COMMAND</p> <p style="font-size: x-large; font-family: cursive;"><i>David A. Peterson</i></p> <p style="font-size: x-small; text-align: right;">AMSRS-AAR-AIL-TP</p>	<p>CAUTION: VERIFY PRIOR TO USE AT WWW.DAC.ARMY.MIL THAT THIS IS THE MOST CURRENT VERSION OF THIS DOCUMENT. THIS IS PAGE 1 OF 4.</p>		
<p style="font-size: x-large; font-family: cursive;"><i>David A. Peterson</i></p> <p style="font-size: x-small; text-align: right;">AMSFS-ST</p>	<p>DO NOT SCALE</p>		<p style="font-size: large;">JULY 1979</p>
<p style="font-size: small;">APPROVED BY ORDER OF COMMANDING GENERAL, U.S. ARMY MATERIEL COMMAND</p> <p style="font-size: x-large; font-family: cursive;"><i>Sally Norstunen</i></p> <p style="font-size: x-small;">F/ James Q. Wheeler U.S. ARMY DEFENSE AMMUNITION CENTER</p>	ENGINEER OR TECHNICIAN	BASIC REV.	<p>GEORGE FECKE</p> <p>ADIN FELICIANO</p>
TRANSPORTATION ENGINEERING DIVISION	<i>G. L. Willie</i>		REVISION NO. 2
VALIDATION ENGINEERING DIVISION	<i>G. L. Willie</i>		APRIL 2005
ENGINEERING DIRECTORATE	<i>G. L. Willie</i>		SEE THE REVISION LISTING ON PAGE 2
TESTED	CLASS	DIVISION	DRAWING
FILE	19	48	4116/ 28A
FILE	20PA1002		

PALLET UNIT DATA				
ITEMS INCLUDED		*HAZARD CLASS AND DIVISION	*COMPATIBILITY GROUP	APPROX WEIGHT (LBS)
NSN	DODIC			
1310-				
00-015-8809	B632	1. 2. 2	E	2, 048
00-028-4944	B632	1. 2. 2	E	2, 048
00-143-7021	B632	1. 2. 2	E	2, 048
00-542-0383	B632	1. 2. 2	E	2, 048
00-926-9308	B632	1. 2. 2	E	2, 048
00-028-4939	B634	1. 2. 2	E	1, 808

*HAZARD AND CLASSIFICATION DATA CONTAINED IN THE ABOVE CHART IS FOR GUIDANCE AND INFORMATIONAL PURPOSES ONLY. VERIFICATION OF THE SPECIFIED DATA SHOULD BE MADE BY CONSULTING THE MOST RECENT JOINT HAZARD CLASSIFICATION SYSTEM LISTING OR OTHER APPROVED LISTING(S).

REVISIONS

REVISION NO. 1, DATED AUGUST 1994, CONSISTS OF:

1. DELETING ITEM BY NATIONAL STOCK NUMBER FROM "PALLET UNIT DATA" CHART.
2. ADDING ITEM BY NATIONAL STOCK NUMBER TO "PALLET UNIT DATA" CHART.

REVISION NO. 2, DATED APRIL 2005, CONSISTS OF:

1. REVISING DRAWING FORMAT.
2. REVISING "PALLET UNIT DATA" CHART FORMAT.
3. REVISING "HAZARD CLASS AND DIVISION" NUMBER FOR ALL ENTRIES IN "PALLET UNIT DATA" CHART.
4. ADDING ITEM BY NATIONAL STOCK NUMBER TO "PALLET UNIT DATA" CHART.

SEAL FOR 3/4" STRAPPING
(6 REQD, 1 PER STRAP).
CRIMP EACH SEAL WITH
TWO PAIR OF NOTCHES.

TIEDOWN STRAP, 3/4" X .035"
OR .031" X 13'-10" LONG
STEEL STRAPPING (4 REQD).
SEE GENERAL NOTE "D"
AT RIGHT.

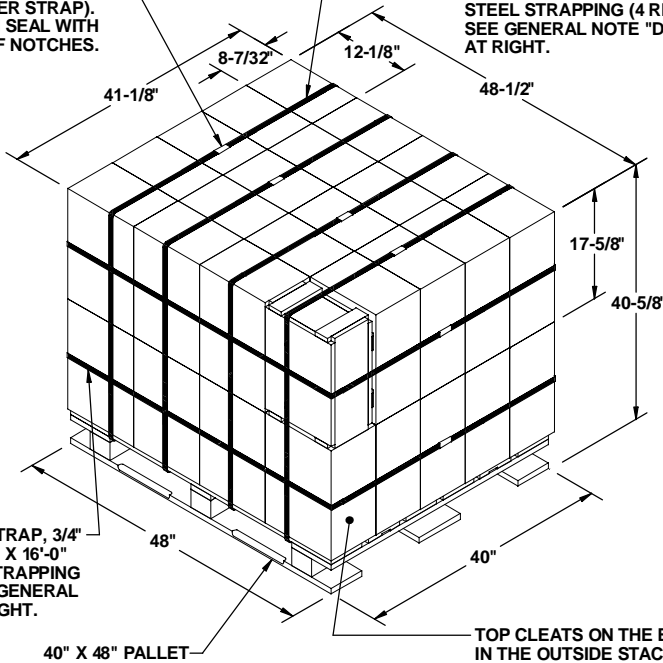

HORIZONTAL STRAP, 3/4"
X .035" OR .031" X 16'-0"
LONG STEEL STRAPPING
(2 REQD). SEE GENERAL
NOTE "C" AT RIGHT.

40" X 48" PALLET

TOP CLEATS ON THE BOXES
IN THE OUTSIDE STACKS WILL
BE TURNED INWARD, EXCEPT
AS OTHERWISE SPECIFIED IN
MIL-STD-129.

PALLET UNIT
SEE GENERAL NOTE "B" AT RIGHT.

GENERAL NOTES

A. THIS APPENDIX CANNOT STAND ALONE BUT MUST BE USED IN CONJUNCTION WITH THE BASIC UNITIZATION PROCEDURES DRAWING 19-48-4116-20PA1002. TO PRODUCE AN APPROVED UNIT LOAD, ALL PERTINENT PROCEDURES, SPECIFICATIONS AND CRITERIA SET FORTH WITHIN THE BASIC DRAWING WILL APPLY TO THE PROCEDURES DELINEATED IN THIS APPENDIX. ANY EXCEPTIONS TO THE BASIC PROCEDURES ARE SPECIFIED IN THIS APPENDIX.

B. DIMENSIONS, CUBE AND WEIGHT OF A PALLET UNIT WILL VARY SLIGHTLY DEPENDING UPON THE ACTUAL DIMENSIONS OF THE BOXES AND THE WEIGHT OF THE SPECIFIC ITEM BEING UNITIZED.

C. INSTALL EACH HORIZONTAL STRAP TO ENIRCLE A LAYER OF BOXES ON THE PALLET. HORIZONTAL STRAPS MUST BE TENSIONED AND SEALED PRIOR TO THE APPLICATION OF TIEDOWN STRAPS

D. INSTALL EACH TIEDOWN STRAP TO PASS UNDER THE TOP DECK BOARDS OF THE PALLET AND TO BE LOCATED AS SHOWN. TIEDOWN STRAPS WILL NOT BE APPLIED UNTIL THE LOAD STRAPS HAVE BEEN TENSIONED AND SEALED.

E. THE FOLLOWING AMC DRAWINGS ARE APPLICABLE FOR UNLOADING AND STORAGE OF THE ITEMS COVERED BY THIS APPENDIX.

CARLOADING - - - - 19-48-4115-5PA1002
TRUCKLOADING - - - - 19-48-4117-11PA1003
STORAGE - - - - - 19-48-4118-1-2-3-4-14-22PA1002

END OPENING ISO
CONTAINER - - - - 19-48-4153-15PA1002
MILVAN - - - - - 19-48-4166-15PA1003
SIDE OPENING ISO
CONTAINER - - - - 19-48-4267-15PA1009

F. IF ITEMS COVERED HEREIN ARE UNITIZED PRIOR TO ISSUANCE OF THIS REVISION TO THIS APPENDIX, THE BOXES NEED NOT BE REUNITIZED SOLELY TO CONFORM TO THIS APPENDIX.

G. THE UNITIZATION PROCEDURES DEPICTED HEREIN MAY ALSO BE USED FOR UNITIZING 60MM CARTRIDGES WHEN IDENTIFIED BY DIFFERENT NATIONAL STOCK NUMBERS (NSN) THAN WHAT IS SHOWN ON PAGE 2, PROVIDED THE BOX PACK DOES NOT VARY FROM WHAT IS DELINEATED HEREIN. THE EXPLOSIVE CLASSIFICATION OF OTHER ITEMS MAY BE DIFFERENT THAN WHAT IS SHOWN.

H. THE STYLE 1 PALLET DELINEATED IN THE DETAIL AT LEFT NEED NOT HAVE CHAMFERS OR STRAP SLOTS AS SPECIFIED WITHIN MILITARY SPECIFICATION MIL-P-15011 WHEN USED FOR THE UNITIZATION OF ITEMS COVERED BY THIS APPENDIX.

J. FOR DETAILS OF THE MIL-B-2427 WOODEN BOX SEE DRAWING 9281170.

40 BOXES OF 60MM CARTRIDGE (10 PER BOX) @ 49 LBS	1,960 LBS
DUNNAGE	8 LBS
PALLET	80 LBS

TOTAL WEIGHT - - - - - 2,048 LBS (APPROX)
CUBE - - - - - 46.9 CU FT (APPROX)

BILL OF MATERIAL

PALLET, 40" X 48"	1 REQD	80 LBS
STEEL STRAPPING, 3/4"	87.33' REQD	7.80 LBS
SEAL FOR 3/4" STRAPPING	6 REQD	0.27 LBS

