

APPENDIX 28

UNITIZATION PROCEDURES FOR BOXED AMMUNITION AND COMPONENTS ON 4-WAY ENTRY PALLETS

CARTRIDGE, 60MM, PACKED 12 PER WOODEN BOX,
UNITIZED 27 BOXES PER 35" X 45-1/2" PALLET;
APPROX BOX SIZE 16-3/8" L X 13-3/4" W X
11-1/2" H

NOTICE: THIS APPENDIX CANNOT STAND ALONE BUT MUST BE USED IN CONJUNCTION WITH THE BASIC UNITIZATION PROCEDURES DRAWING 19-48-4116-20PA1002.

WHEN UNITIZING THE 60MM CARTRIDGES COVERED BY THIS APPENDIX AND THE SPECIFIC STYLE 1A (35" X 45-1/2") IS NOT AVAILABLE, A STYLE 1 PALLET (40" X 48"), IF AVAILABLE, CAN BE SUBSTITUTED FOR THE STYLE 1A PALLET.

DISTRIBUTION STATEMENT A.

APPROVED FOR PUBLIC RELEASE;
DISTRIBUTION IS UNLIMITED.

U. S. ARMY MATERIEL COMMAND DRAWING																		
APPROVED, U.S. ARMY INDUSTRIAL OPERATIONS COMMAND <i>NH</i> <i>David L. Richard</i> AMSTA-AR-ESK	DRAFTSMAN ENGINEER BETTY J. KUNDERT SANDRA M. SCHULTZ																	
APPROVED BY ORDER OF COMMANDING GENERAL, U.S. ARMY MATERIEL COMMAND <i>Angus W. Col</i>	<table border="1" style="width: 100%; border-collapse: collapse;"> <tr> <td style="width: 33%;">SUPPLY ENGINEERING DIVISION <i>T. J. Weich</i></td> <td style="width: 33%;">TRANSPORTATION ENGINEERING DIVISION <i>W. Ernest</i></td> <td style="width: 33%;">VALIDATION ENGINEERING DIVISION <i>J. H. Koch</i></td> </tr> <tr> <td colspan="3" style="text-align: center;">LOGISTICS ENGINEERING OFFICE <i>William F. Ernst</i></td> </tr> <tr> <td colspan="3" style="text-align: center;">JULY 1979</td> </tr> <tr> <td>CLASS</td> <td>DIVISION</td> <td>DRAWING</td> <td>FILE</td> </tr> <tr> <td>19</td> <td>48</td> <td>4116/ 28</td> <td>20PA 1002</td> </tr> </table>	SUPPLY ENGINEERING DIVISION <i>T. J. Weich</i>	TRANSPORTATION ENGINEERING DIVISION <i>W. Ernest</i>	VALIDATION ENGINEERING DIVISION <i>J. H. Koch</i>	LOGISTICS ENGINEERING OFFICE <i>William F. Ernst</i>			JULY 1979			CLASS	DIVISION	DRAWING	FILE	19	48	4116/ 28	20PA 1002
SUPPLY ENGINEERING DIVISION <i>T. J. Weich</i>	TRANSPORTATION ENGINEERING DIVISION <i>W. Ernest</i>	VALIDATION ENGINEERING DIVISION <i>J. H. Koch</i>																
LOGISTICS ENGINEERING OFFICE <i>William F. Ernst</i>																		
JULY 1979																		
CLASS	DIVISION	DRAWING	FILE															
19	48	4116/ 28	20PA 1002															
U.S. ARMY DEFENSE AMMUNITION CENTER AND SCHOOL REVISION NO. 2 MARCH 1996 SEE THE REVISION LISTING ON PAGE 2																		

DO NOT SCALE

PALLET UNIT DATA				
ITEMS INCLUDED		HAZARD CLASS AND DIVISION		APPROX WEIGHT LBS
NSN	DODIC	OD CLASS	COMP GROUP	
1310-				
00-926-9428	B632	(08)1.2	E	1,882
00-935-9130	B632	(08)1.2	E	1,882
01-240-9254	B632	(08)1.2	E	1,882
00-935-1995	B634	(08)1.2	E	1,882
01-276-4075	B634	(08)1.2	E	1,882

- HAZARD CLASSIFICATION DATA CONTAINED IN THE ABOVE CHART IS FOR GUIDANCE AND INFORMATIONAL PURPOSES ONLY. VERIFICATION OF THE SPECIFIED DATA SHOULD BE MADE BY CONSULTING THE MOST RECENT JOINT HAZARD CLASSIFICATION SYSTEM LISTING OR OTHER APPROVED LISTING(S).

REVISION

REVISION NO. 1, DATED APRIL 1989,
CONSISTS OF:

1. ADDING DATA BY NATIONAL STOCK NUMBER (NSN) TO THE "PALLET UNIT DATA" CHART.
2. ADDING GENERAL NOTE.

REVISION NO. 2, DATED MARCH 1986, CONSISTS OF:

1. DELETING ITEMS BY NATIONAL STOCK NUMBER FROM "PALLET UNIT DATA" CHART.
2. ADDING ITEM BY NATIONAL STOCK NUMBER TO "PALLET UNIT DATA" CHART.
3. CHANGING WEIGHT OF ITEMS.

LOAD STRAP, 3/4" X .035" OR .031" X 15'-1" LONG STEEL STRAPPING (3 REQD). SEE GENERAL NOTE "C" AT RIGHT.

SEAL FOR 3/4" STRAPPING (6 REQD, 1 PER STRAP). CRIMP EACH SEAL WITH TWO PAIR OF NOTCHES.

TIEDOWN STRAP, 3/4" X .035" OR .031" X 13'-9" LONG STEEL STRAPPING (3 REQD). SEE GENERAL NOTE "D" AT RIGHT.

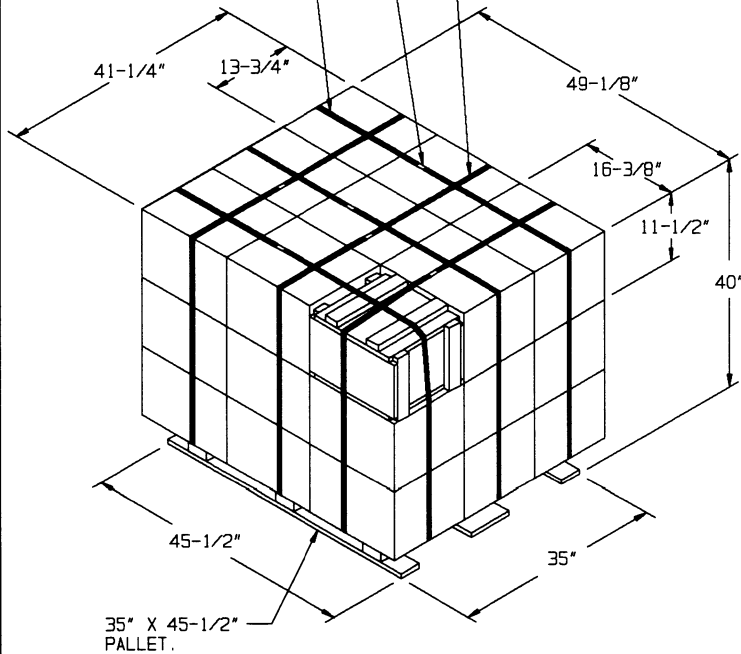

PALLET UNIT

SEE GENERAL NOTE "B" AT RIGHT.

27 BOXES OF 60MM CARTRIDGE (12 PER BOX) AT 67 LBS	-----	1,809 LBS (APPROX)
DUNNAGE	-----	8 LBS
PALLET	-----	65 LBS
<hr/>		
TOTAL WEIGHT	-----	1,882 LBS (APPROX)
CUBE	-----	46.9 CU FT (APPROX)

BILL OF MATERIAL

PALLET, 35" X 45-1/2"	---	1 REQD	-----	65 LBS	
STEEL STRAPPING, 3/4"	-	86.50'	REQD	-----	7.72 LBS
SEAL FOR 3/4" STRAPPING	---	6 REQD	-----	NIL	

GENERAL NOTES

- A. THIS APPENDIX CANNOT STAND ALONE BUT MUST BE USED IN CONJUNCTION WITH THE BASIC UNITIZATION PROCEDURES DRAWING 19-48-4116-20PA1002. TO PRODUCE AN APPROVED UNIT LOAD, ALL PERTINENT PROCEDURES, SPECIFICATIONS AND CRITERIA SET FORTH WITHIN THE BASIC DRAWING WILL APPLY TO THE PROCEDURES DELINEATED IN THIS APPENDIX. ANY EXCEPTIONS TO THE BASIC PROCEDURES ARE SPECIFIED IN THIS APPENDIX.
- B. DIMENSIONS, CUBE AND WEIGHT OF A PALLET UNIT WILL VARY SLIGHTLY DEPENDING UPON THE ACTUAL DIMENSIONS OF THE BOXES AND THE WEIGHT OF THE SPECIFIC ITEM BEING UNITIZED.
- C. THE LOAD STRAPS MAY BE THREADED THROUGH THE STRAP SLOTS OF A PALLET OR PRE-POSITIONED ON THE PALLET DECK PRIOR TO PLACING BOXES ON THE PALLET. LOAD STRAPS MUST BE TENSIONED AND SEALED AFTER APPLICATION OF TIEDOWN STRAPS.
- D. INSTALL EACH TIEDOWN STRAP TO PASS UNDER THE TOP DECK BOARDS OF THE PALLET AND TO BE LOCATED AS SHOWN. TIEDOWN STRAPS WILL BE APPLIED BEFORE THE LOAD STRAPS HAVE BEEN TENSIONED AND SEALED.
- E. THE FOLLOWING AMC DRAWINGS ARE APPLICABLE FOR UNLOADING AND STORAGE OF THE ITEMS COVERED BY THIS APPENDIX.
 - CARLOADING - - - - 19-48-4115-5PA1002
 - TRUCKLOADING - - - - 19-48-4117-11PA1003
 - STORAGE - - - - - 19-48-4118-1-2-3-4-14-22PA1002
 - END OPENING ISO
 - CONTAINER - - - - - 19-48-4153-15PA1002
 - MILVAN - - - - - 19-48-4166-15PA1003
 - SIDE OPENING ISO
 - CONTAINER - - - - - 19-48-4267-15PA1009
- F. IF ITEMS COVERED HEREIN ARE UNITIZED PRIOR TO ISSUANCE OF THIS APPENDIX, THE BOXES NEED NOT BE REUNITIZED SOLELY TO CONFORM TO THIS APPENDIX.
- G. THE UNITIZATION PROCEDURES DEPICTED HEREIN MAY ALSO BE USED FOR UNITIZING 60MM CARTRIDGES WHEN IDENTIFIED BY DIFFERENT NATIONAL STOCK NUMBERS (NSN) THAN WHAT IS SHOWN ON PAGE 2, PROVIDED THE BOX PACK DOES NOT VARY FROM WHAT IS DELINEATED HEREIN. THE EXPLOSIVE CLASSIFICATION OF OTHER ITEMS MAY BE DIFFERENT THAN WHAT IS SHOWN.
- H. THE STYLE 1A PALLET DELINEATED IN THE DETAIL AT LEFT NEED NOT HAVE CHAMFERS OR STRAP SLOTS AS SPECIFIED WITHIN MILITARY SPECIFICATION MIL-P-15011 WHEN USED FOR THE UNITIZATION OF ITEMS COVERED BY THIS APPENDIX.

TIE PIECE, 1" X 4" X BOX WIDTH (2 REQD).
 NAIL TO LONGITUDINAL PIECES W/2-6d NAILS
 AT EACH END AND TO LATERAL PIECE W/1-6d
 NAIL.

VERTICAL PIECE, 2" X 4" X BOX
 HEIGHT MINUS 3/4" (4 REQD).

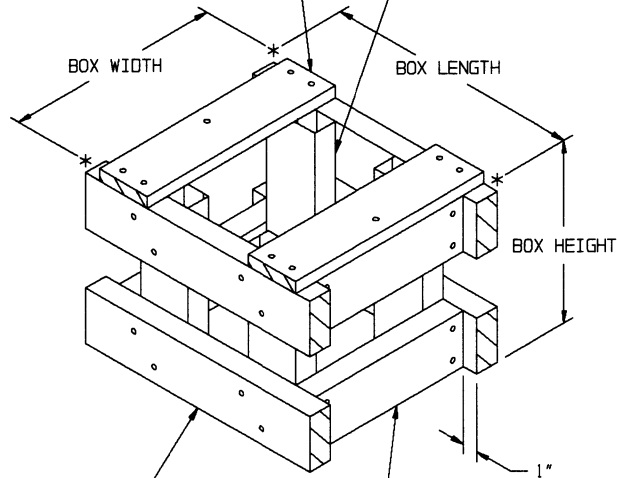

LONGITUDINAL PIECE, 2" X 4" X
 BOX LENGTH (4 REQD). NAIL TO
 VERTICAL PIECES W/2-10d NAILS
 AT EACH END.

LATERAL PIECE, 2" X 4" X BOX WIDTH MINUS
 3" (4 REQD). NAIL TO VERTICAL PIECES
 W/2-10d NAILS AT EACH END.

FILLER ASSEMBLY

(FOR MINUS ONE BOX)