

APPENDIX 27D

UNITIZATION PROCEDURES FOR BOXED AMMUNITION AND COMPONENTS ON 4-WAY ENTRY PALLETS

DUMMY CARTRIDGE, 57MM, PACKED 2 PER WOODEN
BOX, UNITIZED 48 BOXES PER 40" X 48" PALLET;
APPROX BOX SIZE 27 $\frac{3}{4}$ " L X 9 $\frac{3}{4}$ " W X 6 $\frac{1}{2}$ " H

PALLET UNIT DATA						
ITEMS INCLUDED		HAZARD CLASSIFICATION ^①				WEIGHT
NSN	DODIC	DOT CLASS	CG CLASS	QD CLASS	COMP GROUP	(LBS)
1310-00-308-5620	B582	—	—	—	—	2, 316

NOTICE: THIS APPENDIX CANNOT STAND ALONE BUT MUST BE USED IN CONJUNCTION WITH THE BASIC UNITIZATION PROCEDURES DRAWING 19-48-4116-20PA1002.

^① HAZARD CLASSIFICATION DATA CONTAINED IN THE ABOVE CHART IS FOR GUIDANCE AND INFORMATIONAL PURPOSES ONLY. VERIFICATION OF THE SPECIFIED DATA SHOULD BE MADE BY CONSULTING THE MOST RECENT JOINT HAZARD CLASSIFICATION SYSTEM LISTING OR OTHER APPROVED LISTING(S).

DO NOT SCALE

REVISIONS				DRAFTSMAN <i>R. B. B...</i>	PROJ ENG <i>R. B. B...</i>
				CHECKER <i>R. B. B...</i>	LOG ENGINE OFFICER <i>R. B. B...</i>
APPROVED, U. S. ARMY ARMAMENT, MUNITIONS AND CHEMICAL COMMAND					
			<i>Keith W. Benton</i>		
APPROVED BY ORDER OF COMMANDING GENERAL, U. S. ARMY MATERIEL DEVELOPMENT AND READINESS COMMAND (DARCOM)					
<i>James A. Reynolds</i>					
U. S. ARMY DEFENSE AMMUNITION CENTER AND SCHOOL					
U. S. ARMY DARCOM DRAWING					
SEPTEMBER 1983					
CLASS	DIVISION	DRAWING	FILE		
19	48	4116/27D	20PA 1002		

SEAL FOR 3/4" STRAPPING, (8 REQD, 1 PER STRAP). CRIMP EACH SEAL WITH TWO PAIR OF NOTCHES.

TIEDOWN STRAP, 3/4" X .035" OR .031" X 14'-4" LONG STEEL STRAPPING (4 REQD). SEE GENERAL NOTE "D" AT RIGHT.

SPACER ASSEMBLY (1 REQD). SEE THE DETAIL BELOW. STAPLE TIEDOWN STRAPS TO SPACER ASSEMBLY AS SHOWN.

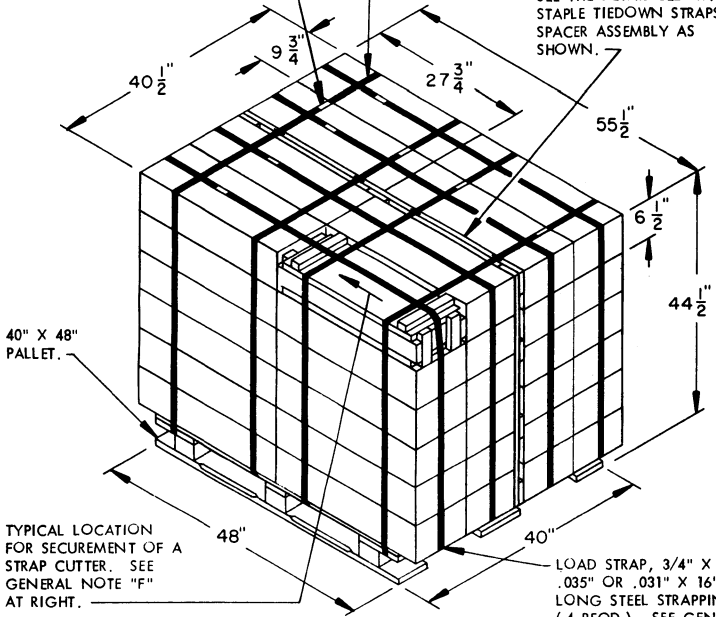

TYPICAL LOCATION FOR SECUREMENT OF A STRAP CUTTER. SEE GENERAL NOTE "F" AT RIGHT.

LOAD STRAP, 3/4" X .035" OR .031" X 16'-10" LONG STEEL STRAPPING (4 REQD). SEE GENERAL NOTE "C" AT RIGHT.

PALLET UNIT

SEE GENERAL NOTE "B" AT RIGHT.

48 BOXES OF 57MM DUMM CARTRIDGES (2 PER BOX) = 46 LBS----- 2,208 LBS (APPROX)
 DUNNAGE----- 28 LBS
 PALLET----- 80 LBS

TOTAL WEIGHT----- 2,316 LBS (APPROX)
 CUBE----- 57.9 CU FT (APPROX)

BILL OF MATERIAL

LUMBER	LINEAR FEET	BOARD FEET
1" X 4"	27.89	9.30
NAILS	NO. REQD	POUNDS
6d (2")	24	0.15

PALLET, 40" X 48" -----	1 REQD -----	80 LBS
STEEL STRAPPING, 3/4" -----	124.67 REQD -----	8.91 LBS
SEAL FOR 3/4" STRAPPING ---	8 REQD -----	NIL
STAPLE -----	4 REQD -----	NIL

GENERAL NOTES

- A. THIS APPENDIX CANNOT STAND ALONE BUT MUST BE USED IN CONJUNCTION WITH THE BASIC UNITIZATION PROCEDURES DRAWING 19-48-4116-20PA1002. TO PRODUCE AN APPROVED UNIT LOAD, ALL PERTINENT PROCEDURES, SPECIFICATIONS AND CRITERIA SET FORTH WITHIN THE BASIC DRAWING WILL APPLY TO THE PROCEDURES DELINEATED IN THIS APPENDIX. ANY EXCEPTIONS TO THE BASIC PROCEDURES ARE SPECIFIED IN THIS APPENDIX.
- B. DIMENSIONS, CUBE AND WEIGHT OF A PALLET UNIT WILL VARY SLIGHTLY DEPENDING UPON THE ACTUAL DIMENSIONS OF THE BOXES AND THE WEIGHT OF THE SPECIFIC ITEM BEING UNITIZED.
- C. THE LOAD STRAPS WILL BE PRE-POSITIONED ON THE PALLET DECK PRIOR TO PLACING BOXES ON THE PALLET.
- D. INSTALL EACH TIEDOWN STRAP TO PASS UNDER THE DECK/STRINGER BOARDS OF THE PALLET AND TO BE LOCATED AS SHOWN. TIEDOWN STRAPS WILL BE TENSIONED AND SEALED PRIOR TO LOAD STRAPS.
- E. THE FOLLOWING DARCOM DRAWINGS ARE APPLICABLE FOR OUTLOADING AND STORAGE OF THE ITEMS COVERED BY THIS APPENDIX.
 - CARLOADING ----- DRAWING 19-48-4115-5PA1002
 - TRUCKLOADING ----- DRAWING 19-48-4117-11PA1003
 - STORAGE ----- DRAWING 19-48-4118-1-2-3-4-14-22PA1002
- F. FOR METHOD OF SECURING A STRAP CUTTER TO THE PALLET UNIT, SEE DARCOM DRAWING 19-48-4127-20P1000.
- G. IF ITEMS COVERED HEREIN ARE UNITIZED PRIOR TO ISSUANCE OF THIS APPENDIX, THE BOXES NEED NOT BE REUNITIZED SOLELY TO CONFORM TO THIS APPENDIX.
- H. THE UNITIZATION PROCEDURES DEPICTED HEREIN MAY ALSO BE USED FOR UNITIZING 57MM DUMMY CARTRIDGES WHEN IDENTIFIED BY DIFFERENT NATIONAL STOCK NUMBERS (NSN) THAN WHAT IS SHOWN ON THE TITLE PAGE, PROVIDED THE BOX PACK DOES NOT VARY FROM WHAT IS DELINEATED HEREIN. THE EXPLOSIVE CLASSIFICATION OF OTHER ITEMS MAY BE DIFFERENT THAN WHAT IS SHOWN.
- J. WHEN THE UNIT LOAD DEPICTED AT LEFT IS TO BE USED FOR UNITIZING MARINE CORPS AMMUNITION, ONE LAYER OF BOXES MUST BE OMITTED, TIEDOWN STRAP LENGTHS MUST BE DECREASED TO 13'-3", AND LOAD STRAP LENGTHS MUST BE DECREASED TO 15'-9", AND THE SPACER ASSEMBLY MUST BE MODIFIED. SPACER ASSEMBLY MODIFICATIONS INCLUDE CHANGING VERTICAL PIECE LENGTHS TO 31'-1/4" AND LOCATING THE TOP HORIZONTAL PIECE AT 31'-1/4". THIS WILL RESULT IN AN OVERALL UNIT HEIGHT OF 38", A GROSS UNIT WEIGHT OF 1,946 POUNDS, AND A UNIT CUBE OF 49.4 CU FT. ADDITIONALLY, THE UNIT LOAD MAY BE MODIFIED AS DESCRIBED WHEN BEING SHIPPED BY MILVAN OR COMMERCIAL INTERMODAL FREIGHT CONTAINER, CONVENTIONAL VAN TRAILER OR CONVENTIONAL OR HIGH-CAPACITY BOXCAR. THE DETERMINATION TO REDUCE THE LOAD BY A LAYER FOR TRANSPORTATION WILL BE MADE BY THE RESPONSIBLE COMMAND AND WILL BE BASED UPON ECONOMICS OF TRANSPORTATION AND HANDLING.

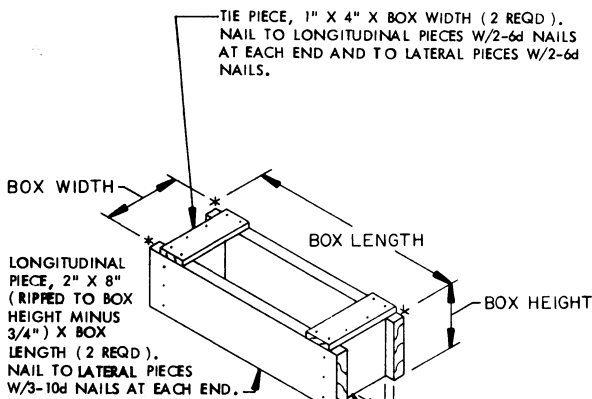

FILLER ASSEMBLY

(FOR MINUS ONE BOX)

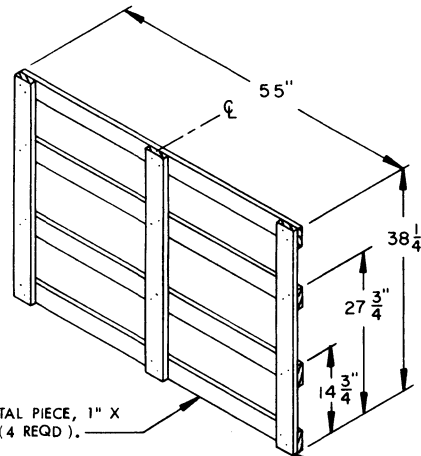

SPACER ASSEMBLY

(1 REQD.)