

# APPENDIX 27B

## UNITIZATION PROCEDURES FOR BOXED AMMUNITION AND COMPONENTS ON 4-WAY ENTRY PALLETS

CARTRIDGE, 57MM, PACKED 6 PER WOODEN BOX,  
UNITIZED 36 BOXES PER 35" X 45½" PALLET;  
APPROX BOX SIZE 19¼" L X 10⅝" W 8⅛" H

PALLET UNIT DATA						
ITEMS INCLUDED		HAZARD CLASSIFICATION				WEIGHT
NSN	DODIC	DOT CLASS	CG CLASS	QD CLASS	COMP GROUP	( LBS )
1310-00-028-4580	8585	B	II-B	( 08 ) 1.2	C	1,836
00-926-3953	8585	B	II-B	( 08 ) 1.2	C	1,836

NOTICE: THIS APPENDIX CANNOT STAND ALONE BUT MUST BE USED IN CONJUNCTION WITH THE BASIC UNITIZATION PROCEDURES DRAWING 19-48-4116-20PA1002.

REVISIONS				DRAFTSMAN	PROJ ENG
				<i>[Signature]</i>	<i>[Signature]</i>
				CHECKER	LOG ENGINE OFFICER
				<i>[Signature]</i>	<i>[Signature]</i>
APPROVED, U. S. ARMY ARMAMENT MATERIEL READINESS COMMAND					
<i>[Signature]</i>		<i>[Signature]</i>			
DRSAR - MAD		DRSAR - FND			
APPROVED BY ORDER OF COMMANDING GENERAL, U. S. ARMY MATERIEL DEVELOPMENT AND READINESS COMMAND (DARCOM)					
<i>[Signature]</i>					
U. S. ARMY DEFENSE AMMUNITION CENTER AND SCHOOL					
U. S. ARMY DARCOM DRAWING					
JULY 1979					
CLASS	DIVISION	DRAWING	FILE		
19	48	4116/27B	20PA 1002		

**DO NOT SCALE**

SEAL FOR 3/4" STRAPPING (8 REQD, 1 PER STRAP). CRIMP EACH SEAL WITH TWO PAIR OF NOTCHES.

LOAD STRAPS, 3/4" X .035" OR .031" X 14'-5" LONG STEEL STRAPPING (2 REQD). SEE GENERAL NOTE "C" AT RIGHT.

TIEDOWN STRAP, 3/4" X .035" OR .031" X 12'-8" LONG STEEL STRAPPING (5 REQD). SEE GENERAL NOTE "D" AT RIGHT.

**GENERAL NOTES**

- A. THIS APPENDIX CANNOT STAND ALONE BUT MUST BE USED IN CONJUNCTION WITH THE BASIC UNITIZATION PROCEDURES DRAWING 19-48-4116-20PA1002. TO PRODUCE AN APPROVED UNIT LOAD, ALL PERTINENT PROCEDURES, SPECIFICATIONS AND CRITERIA SET FORTH WITHIN THE BASIC DRAWING WILL APPLY TO THE PROCEDURES DELINEATED IN THIS APPENDIX. ANY EXCEPTIONS TO THE BASIC PROCEDURES ARE SPECIFIED IN THIS APPENDIX.
- B. DIMENSIONS, CUBE AND WEIGHT OF A PALLET UNIT WILL VARY SLIGHTLY DEPENDING UPON THE ACTUAL DIMENSIONS OF THE BOXES AND THE WEIGHT OF THE SPECIFIC ITEM BEING UNITIZED.
- C. THE LOAD STRAPS MAY BE THREADED THROUGH THE STRAP SLOTS OF A PALLET OR PRE-POSITIONED ON THE PALLET DECK PRIOR TO PLACING BOXES ON THE PALLET. LOAD STRAPS MUST BE TENSIONED AND SEALED PRIOR TO APPLICATION OF TIEDOWN STRAPS.
- D. INSTALL EACH TIEDOWN STRAP TO PASS UNDER THE DECK/STRINGER BOARDS OF THE PALLET AND TO BE LOCATED AS SHOWN. TIEDOWN STRAPS WILL NOT BE APPLIED UNTIL THE LOAD STRAPS HAVE BEEN TENSIONED AND SEALED.
- E. THE FOLLOWING DARCOM DRAWINGS ARE APPLICABLE FOR OUTLOADING AND STORAGE OF THE ITEMS COVERED BY THIS APPENDIX.
  - CARLOADING ----- DRAWING 19-48-4115-5PA1002
  - TRUCKLOADING ----- DRAWING 19-48-4117-11PA1003
  - STORAGE ----- DRAWING 19-48-4118-1-2-14-22PA1002
- F. FOR METHOD OF SECURING A STRAP CUTTER TO THE PALLET UNIT, SEE DARCOM DRAWING 19-48-4127-20P1000.
- G. IF ITEMS COVERED HEREIN ARE UNITIZED PRIOR TO ISSUANCE OF THIS APPENDIX, THE BOXES NEED NOT BE REUNITIZED SOLELY TO CONFORM TO THIS APPENDIX.
- H. THE UNITIZATION PROCEDURES DEPICTED HEREIN MAY ALSO BE USED FOR UNITIZING 57MM CARTRIDGES WHEN IDENTIFIED BY DIFFERENT NATIONAL STOCK NUMBERS (NSN) THAN WHAT IS SHOWN ON THE TITLE PAGE, PROVIDED THE BOX PACK DOES NOT VARY FROM WHAT IS DELINEATED HEREIN. THE EXPLOSIVE CLASSIFICATION OF OTHER ITEMS MAY BE DIFFERENT THAN WHAT IS SHOWN.

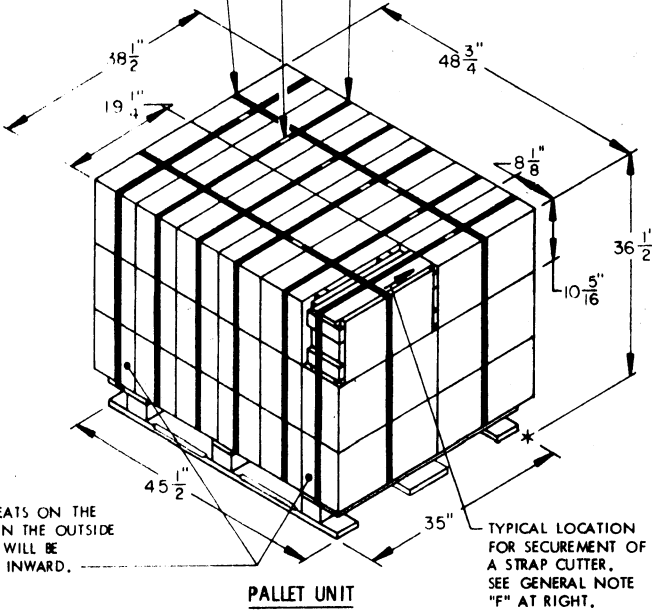

SEE GENERAL NOTE "B" AT RIGHT.

36 BOXES OF 57MM CARTRIDGE (6 PER BOX) @ 49 LBS -----	1,764 LBS (APPROX)
DUNNAGE -----	7 LBS
PALLET -----	65 LBS
<hr/>	
TOTAL WEIGHT -----	1,836 LBS (APPROX)
CUBE -----	39.6 CU FT (APPROX)

**BILL OF MATERIAL**

PALLET, 35" X 45-1/2" -----	1 REQD -----	65 LBS
STEEL STRAPPING, 3/4" -----	92.17' REQD -----	6.58 LBS
SEAL FOR 3/4" STRAPPING -----	8 REQD -----	NIL

VERTICAL PIECE, 2" X 4" X BOX WIDTH (4 REQD).

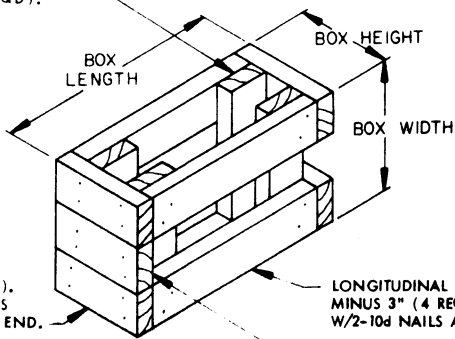

LATERAL PIECE, 2" X 4" X BOX HEIGHT (4 REQD). NAIL TO VERTICAL PIECES W/2-10d NAILS AT EACH END.

LONGITUDINAL PIECE, 2" X 4" X BOX LENGTH MINUS 3" (4 REQD). NAIL TO VERTICAL PIECES W/2-10d NAILS AT EACH END.

FILLER PIECE, 2" X 4" X BOX HEIGHT (1 REQD). NAIL TO VERTICAL PIECES W/2-10d NAILS AT EACH END.

**FILLER ASSEMBLY**

(FOR MINUS ONE BOX)