

APPENDIX 26Q

UNITIZATION PROCEDURES FOR BOXED AMMUNITION AND COMPO- NENTS ON 4-WAY ENTRY PALLETS

**CARTRIDGE, 40MM, PRACTICE, M781 OR TARGET
PRACTICE DAY/NIGHT/THERMAL (TP-DNT), M781E1,
PACKED 25 PER FIBERBOARD BOX, 4 BOXES PER
WIREBOUND BOX, UNITIZED 20 BOXES PER 42" X
53" PALLET; APPROX BOX SIZE 22-3/8" L X
10-13/16" W X 10-5/8" H**

**NOTICE: THIS APPENDIX CANNOT STAND ALONE BUT MUST BE USED IN CONJUNCTION WITH THE BASIC UNITIZATION
PROCEDURES DRAWING 19-48-4116-20PA1002.**

DISTRIBUTION STATEMENT A:

**APPROVED FOR PUBLIC RELEASE
DISTRIBUTION IS UNLIMITED.**

U.S. ARMY MATERIEL COMMAND DRAWING

<p>APPROVED, COMBAT CAPABILITIES DEVELOPMENT COMMAND ARMAMENTS CENTER</p> <p>HANSEN.JO SEPH.W.1376 495538</p> <p><small>Digitally signed by HANSEN.JOSEPH.W. 1376495538 Date: 2019.04.04 13:48:53 -05'00'</small></p> <p style="text-align: right;">FCDD-ACE-LTP</p>	<p>CAUTION: VERIFY PRIOR TO USE AT https://www.dau.mil/cop/ammo/Pages/Default.aspx THAT THIS IS THE MOST CURRENT VERSION OF THIS DOCUMENT. THIS IS PAGE 1 OF 4.</p>			<p>SEPTEMBER 1985</p>				
<p>APPROVED, U.S. ARMY JOINT MUNITIONS COMMAND</p> <p>RUS.ALLEN.J .1230354282</p> <p><small>Digitally signed by RUS.ALLEN.J.1230354282 Date: 2019.04.05 08:56:05 -05'00'</small></p> <p style="text-align: right;">AMSJM-MMT</p>	<p>DO NOT SCALE</p>	<p>LAURA A. FIEFFER</p>		<p>REVISION NO. 2</p>		<p>MARCH 2019</p>		
<p>APPROVED BY ORDER OF COMMANDING GENERAL, U.S. ARMY MATERIEL COMMAND</p> <p>THOMAS.CARL.AN THONY.110462137 2</p> <p><small>Digitally signed by THOMAS.CARL.ANTHONY.1104 621372 Date: 2019.04.05 10:41:41 -05'00'</small></p> <p style="text-align: right;">U.S. ARMY DEFENSE AMMUNITION CENTER</p>	<p>DESIGN ENGINEER</p>	<p>BASIC</p>	<p>LAURA A. FIEFFER</p>		<p>SEE THE REVISION LISTING ON PAGE 2</p>			
	<p>ENGINEERING DIVISON</p>		<p>FIEFFER.LAUR A.A.1230375727</p> <p><small>Digitally signed by FIEFFER.LAURA.A.1230375727 Date: 2019.03.05 15:32:09 -06'00'</small></p>		<p>CLASS</p>	<p>DIVISION</p>	<p>DRAWING</p>	<p>FILE</p>
	<p>TEST ENGINEER</p>	<p>TEST REPORT</p>	<p>NA</p>		<p>19</p>	<p>48</p>	<p>4116/26Q</p>	<p>20PA1002</p>
	<p>EXPLOSIVE SAFETY DIRECTORATE</p>		<p>BARICKMAN.PHIL IP.W.1230202202</p> <p><small>Digitally signed by BARICKMAN.PHILIP.W.12302022 02 Date: 2019.03.20 10:28:17 -05'00'</small></p>					

PALLET UNIT DATA				
ITEMS INCLUDED		*HAZARD CLASS AND DIVISION	*COMPATIBILITY GROUP	APPROX WEIGHT (LBS)
NSN	DODIC			
1310-				
01-211-8073	B519	1.4	S	1,319
01-667-2668	BA54	1.4	C	1,319

*HAZARD CLASSIFICATION DATA CONTAINED IN THE ABOVE CHART IS FOR GUIDANCE AND INFORMATIONAL PURPOSES ONLY. VERIFICATION OF THE SPECIFIED DATA SHOULD BE MADE BY CONSULTING THE MOST RECENT JOINT HAZARD CLASSIFICATION SYSTEM LISTING OR OTHER APPROVED LISTING(S).

REVISION

REVISION NO. 1, DATED DECEMBER 1985, CONSISTS OF:

1. ADDING ITEM BY NATIONAL STOCK NUMBER TO "PALLET UNIT DATA" CHART.

REVISION NO. 2, DATED MARCH 2019, CONSISTS OF CHANGES PER ECP R17K2017 (1 AND 2) INCLUDING:

1. ADDING ITEM BY NATIONAL STOCK NUMBER TO "PALLET UNIT DATA" CHART.
2. ADDING "DISTRIBUTION STATEMENT A".
3. UPDATING DRAWING TO CURRENT STANDARDS.

GENERAL NOTES

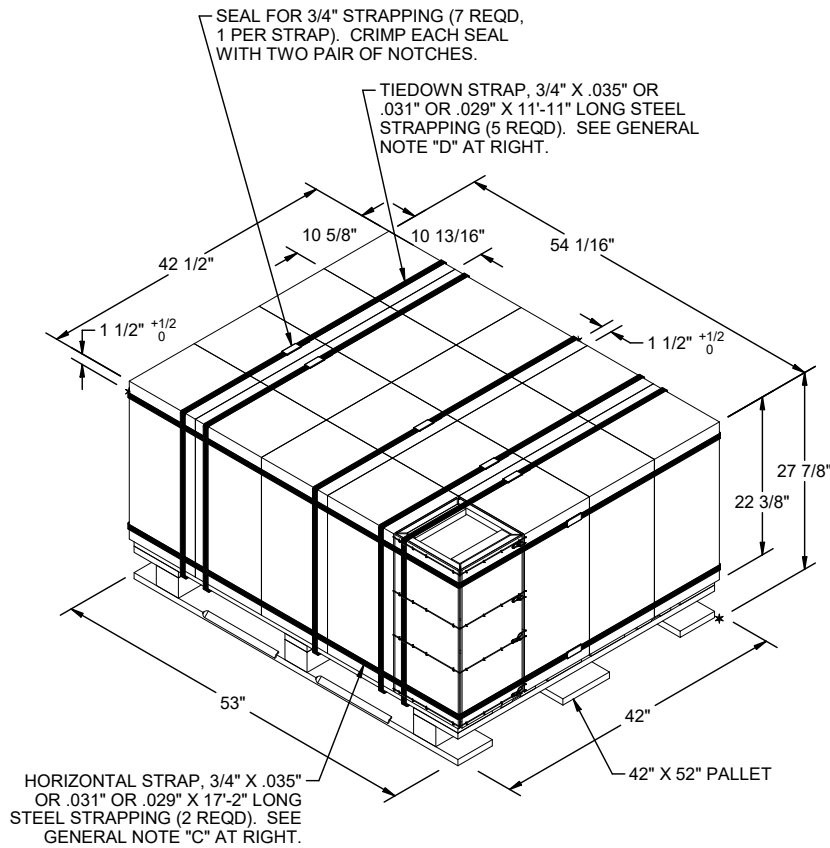

A. THIS APPENDIX CANNOT STAND ALONE BUT MUST BE USED IN CONJUNCTION WITH THE BASIC UNITIZATION PROCEDURES DRAWING 19-48-4116-20PA1002. TO PRODUCE AN APPROVED UNIT LOAD, ALL PERTINENT PROCEDURES, SPECIFICATIONS AND CRITERIA SET FORTH WITHIN THE BASIC DRAWING WILL APPLY TO THE PROCEDURES DELINEATED IN THIS APPENDIX. ANY EXCEPTIONS TO THE BASIC PROCEDURES ARE SPECIFIED IN THIS APPENDIX.

B. DIMENSIONS, CUBE AND WEIGHT OF A PALLET UNIT WILL VARY SLIGHTLY DEPENDING UPON THE ACTUAL DIMENSIONS OF THE BOXES AND THE WEIGHT OF THE SPECIFIC ITEM BEING UNITIZED.

C. INSTALL EACH HORIZONTAL STRAP TO ENCIRCLE THE BOXES ON THE PALLET. NOTE THAT THE STRAPS WILL BE LOCATED AS SHOWN, NEAR THE TOP AND BOTTOM OF THE LAYER. HORIZONTAL STRAPS MUST BE TENSIONED AND SEALED PRIOR TO THE APPLICATION OF TIEDOWN STRAPS.

D. INSTALL EACH TIEDOWN STRAP TO PASS UNDER THE TOP DECK BOARDS OF THE PALLET. NOTE THAT THE STRAPS WILL BE LOCATED AS SHOWN, NEAR THE SIDE CLEATS OF THE END PANELS OF THE BOX. TIEDOWN STRAPS WILL NOT BE APPLIED UNTIL THE HORIZONTAL STRAPS HAVE BEEN TENSIONED AND SEALED.

E. THE FOLLOWING AMC DRAWINGS ARE APPLICABLE FOR OUTLOADING AND STORAGE OF THE ITEMS COVERED BY THIS APPENDIX.

CARLOADING	- - - -	19-48-4115-5PA1002
TRUCKLOADING	- - - -	19-48-4117-11PA1003
STORAGE	- - - -	19-48-4118-1-2-3-4-14-22PA1002
END OPENING ISO		
CONTAINER	- - - -	19-48-4153-15PA1002
MILVAN	- - - -	19-48-4166-15PA1003
SIDE OPENING ISO		
CONTAINER	- - - -	19-48-4267-15PA1009

F. IF ITEMS COVERED HEREIN ARE UNITIZED PRIOR TO ISSUANCE OF THIS REVISION TO THIS APPENDIX, THE BOXES NEED NOT BE REUNITIZED SOLELY TO CONFORM TO THIS REVISION.

G. THE UNITIZATION PROCEDURES DEPICTED HEREIN MAY ALSO BE USED FOR UNITIZING 40MM CARTRIDGES WHEN IDENTIFIED BY DIFFERENT NATIONAL STOCK NUMBERS (NSN) THAN WHAT IS SHOWN ON PAGE 2, PROVIDED THE BOX PACK DOES NOT VARY FROM WHAT IS DELINEATED HEREIN. THE EXPLOSIVE CLASSIFICATION OF OTHER ITEMS MAY BE DIFFERENT THAN WHAT IS SHOWN.

H. THE STYLE 1B PALLET DELINEATED IN THE DETAIL AT LEFT NEED NOT HAVE CHAMFERS OR STRAP SLOTS AS SPECIFIED WITHIN MILITARY SPECIFICATION MIL-DTL-15011 WHEN USED FOR THE UNITIZATION OF ITEMS COVERED BY THIS APPENDIX.

J. IF THERE IS NEED FOR FILLER ASSEMBLIES AND AT LEAST TWO PALLET UNITS ARE BEING CONSTRUCTED, NOT MORE THAN 16 FILLERS WILL BE INSTALLED IN ANY ONE PALLET UNIT. ADDITIONAL FILLERS CAN BE PUT IN A SECOND PALLET UNIT AS REQUIRED WHEN THE QUANTITY OF 16 FILLERS IN THE FIRST REDUCED PALLET UNIT IS INSUFFICIENT TO SATISFY THE TOTAL REDUCTION NEEDED. USING TWO PALLET UNITS TO SATISFY THE PALLETIZATION CRITERIA APPLICABLE TO LESS-THAN-FULL PALLET UNITS IS AN EXCEPTION TO THE BASIC PROCEDURES. HOWEVER, THE EXCEPTION IS NECESSARY FOR THE AMMUNITION PACK COVERED BY THIS APPENDIX TO MOST EFFECTIVELY GET AN ACCEPTABLE, COMPACT AND SOUND PALLET UNIT.

K. FOR DETAILS OF THE WIREBOUND BOX SEE ARDEC DRAWING 9325896 OR 13071653.

PALLET UNIT
SEE GENERAL NOTE "B" AT RIGHT.

20 BOXES OF 40MM CARTRIDGES (100 PER BOX) @ 61 LBS	- - - -	1,220 LBS (APPROX)
DUNNAGE	- - - -	9 LBS
PALLET	- - - -	90 LBS
<hr/>		
TOTAL WEIGHT	- - - -	1,319 LBS (APPROX)
CUBE	- - - -	37.1 CU FT (APPROX)

BILL OF MATERIAL			
PALLET, 42" X 53"	- - - -	1 REQD	- - - - 90 LBS
STEEL STRAPPING, 3/4"	- 93.92'	REQD	- - - - 8.39 LBS
SEAL FOR 3/4" STRAPPING	- - - -	7 REQD	- - - - NIL

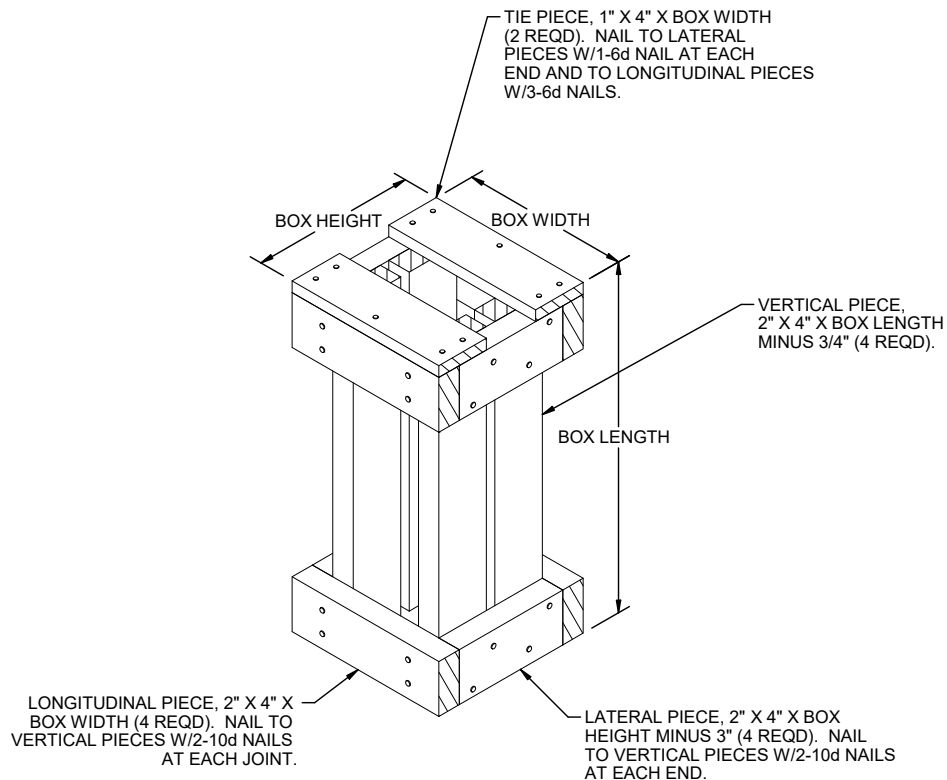

FILLER ASSEMBLY
(FOR MINUS ONE BOX)