

## APPENDIX 26P

# UNITIZATION PROCEDURES FOR BOXED AMMUNITION AND COMPONENTS ON 4-WAY ENTRY PALLETS

CARTRIDGE, 40MM, PACKED 20 PER WOODEN BOX,  
UNITIZED 18 BOXES PER 40" X 48" PALLET;  
APPROX BOX SIZE 25" L X 15 $\frac{3}{8}$ " W X 14 $\frac{1}{4}$ " H

PALLET UNIT DATA						
ITEMS INCLUDED		HAZARD CLASSIFICATION <sup>①</sup>				WEIGHT (LBS)
NSN	DOD IC	DOT CLASS	CG CLASS	QD CLASS	COMP GROUP	
UN- ASSIGNED	B511	—	—	—	—	2,969
	B517	—	—	—	—	2,969
	B518	—	—	—	—	2,969
	B583	—	—	—	—	2,969

① HAZARD CLASSIFICATION DATA CONTAINED IN THE ABOVE CHART IS FOR GUIDANCE AND INFORMATIONAL PURPOSES ONLY. VERIFICATION OF THE SPECIFIED HAZARD DATA SHOULD BE MADE BY CONSULTING THE MOST RECENT JOINT HAZARD CLASSIFICATION SYSTEM LISTING OR OTHER APPROVED LISTING(S).

NOTICE: THIS APPENDIX CANNOT STAND ALONE BUT MUST BE USED IN CONJUNCTION WITH THE BASIC UNITIZATION PROCEDURES DRAWING 19-48-4116-20PA1002.

**DO NOT SCALE**

REVISIONS				DRAFTSMAN <i>gw</i>	PROJ ENG <i>bh</i>
				CHECKER <i>W &amp; Ernst</i>	LOG ENGRG OFFICE <i>W &amp; Ernst</i>
				APPROVED, U.S. ARMY ARMAMENT, MUNITIONS AND CHEMICAL COMMAND <i>W. Martin</i>	
				APPROVED BY ORDER OF COMMANDING GENERAL, U.S. ARMY MATERIEL DEVELOPMENT AND READINESS COMMAND (DARCOM) <i>John X. Boyall</i>	
U. S. ARMY DARCOM DRAWING					
MARCH 1984					
				CLASS	DIVISION
				DRAWING	FILE
				19	48
				4116/ 26P	20PA 1002

LOAD STRAP, 3/4" X .035" OR .031" X 17'-2" LONG STEEL STRAPPING (3 REQD). SEE GENERAL NOTE "C" AT RIGHT.

SEAL FOR 3/4" STRAPPING (7 REQD, 1 PER STRAP). CRIMP EACH SEAL WITH TWO PAIR OF NOTCHES.

THE TOP CLEATS ON THE BOXES IN THE OUTSIDE STACKS WILL BE TURNED INWARD, EXCEPT AS OTHERWISE SPECIFIED IN MIL-STD-129.

TIEDOWN STRAP, 3/4" X .035" OR .031" X 15'-11" LONG STEEL STRAPPING (4 REQD). SEE GENERAL NOTE "D" AT RIGHT.

40" X 48" PALLET.

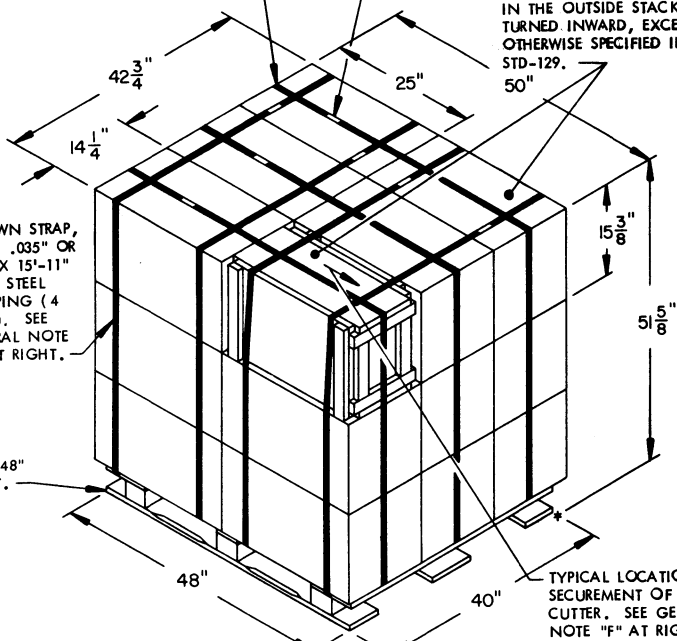

**PALLET UNIT**

SEE GENERAL NOTE "B" AT RIGHT.

18 BOXES OF 40MM CARTRIDGES (20 PER BOX) @ 160 LBS	-----	2,880 LBS (APPROX)
DUNNAGE	-----	9 LBS
PALLET	-----	80 LBS

TOTAL WEIGHT	-----	2,969 LBS (APPROX)
CUBE	-----	63.9 CU FT. (APPROX)

**GENERAL NOTES**

- A. THIS APPENDIX CANNOT STAND ALONE BUT MUST BE USED IN CONJUNCTION WITH THE BASIC UNITIZATION PROCEDURES DRAWING 19-48-4116-20PA1002. TO PRODUCE AN APPROVED UNIT LOAD, ALL PERTINENT PROCEDURES, SPECIFICATIONS AND CRITERIA SET FORTH WITHIN THE BASIC DRAWING WILL APPLY TO THE PROCEDURES DELINEATED IN THIS APPENDIX. ANY EXCEPTIONS TO THE BASIC PROCEDURES ARE SPECIFIED IN THIS APPENDIX.
- B. DIMENSIONS, CUBE AND WEIGHT OF A PALLET UNIT WILL VARY SLIGHTLY DEPENDING UPON THE ACTUAL DIMENSIONS OF THE BOXES AND THE WEIGHT OF THE SPECIFIC ITEM BEING UNITIZED.
- C. THE LOAD STRAPS WILL BE PRE-POSITIONED ON THE PALLET DECK PRIOR TO PLACING BOXES ON THE PALLET. LOAD STRAPS MUST BE TENSIONED AND SEALED PRIOR TO APPLICATION OF TIEDOWN STRAPS.
- D. INSTALL EACH TIEDOWN STRAP TO PASS UNDER THE TOP DECK/ STRINGER BOARDS OF THE PALLET AND TO BE LOCATED AS SHOWN. TIEDOWN STRAPS WILL NOT BE APPLIED UNTIL THE LOAD STRAPS HAVE BEEN TENSIONED AND SEALED.
- E. THE FOLLOWING DARCOM DRAWINGS ARE APPLICABLE FOR OUT-LOADING AND STORAGE OF THE ITEMS COVERED BY THIS APPENDIX.
 

CARLOADING	-----	DRAWING 19-48-4115-5PA1002
TRUCKLOADING	-----	DRAWING 19-48-4117-11PA1003
STORAGE	-----	DRAWING 19-48-4118-1-2-3-4-14-22PA1002
- F. FOR METHOD OF SECURING A STRAP CUTTER TO THE PALLET UNIT, SEE DARCOM DRAWING 19-48-4127-20P1000.
- G. IF ITEMS COVERED HEREIN ARE UNITIZED PRIOR TO ISSUANCE OF THIS APPENDIX, THE BOXES NEED NOT BE REUNITIZED SOLELY TO CONFORM TO THIS APPENDIX.
- H. THE UNITIZATION PROCEDURES DEPICTED HEREIN MAY ALSO BE USED FOR UNITIZING 40MM CARTRIDGES WHEN IDENTIFIED BY DIFFERENT NATIONAL STOCK NUMBERS (NSN) THAN WHAT IS SHOWN ON THE TITLE PAGE, PROVIDED THE BOX PACK DOES NOT VARY FROM WHAT IS DELINEATED HEREIN. THE EXPLOSIVE CLASSIFICATION OF OTHER ITEMS MAY BE DIFFERENT THAN WHAT IS SHOWN.
- J. WHEN THE UNIT LOAD DEPICTED AT LEFT IS TO BE USED FOR UNITIZING MARINE CORPS AMMUNITION, ONE LAYER OF BOXES MUST BE OMITTED, TIEDOWN STRAP LENGTHS MUST BE DECREASED TO 13'-4", AND LOAD STRAP LENGTHS MUST BE DECREASED TO 14'-7". THIS WILL RESULT IN AN OVERALL UNIT HEIGHT OF 36'-1/4", A GROSS UNIT WEIGHT OF 2,007 POUNDS, AND A UNIT CUBE OF 44.8 CUBIC FEET. ADDITIONALLY, THE UNIT LOAD MAY BE MODIFIED AS DESCRIBED WHEN BEING SHIPPED BY MILVAN OR COMMERCIAL INTER-MODAL FREIGHT CONTAINER, CONVENTIONAL VAN TRAILER OR CONVENTIONAL OR HIGH-CAPACITY BOXCAR. THE DETERMINATION TO REDUCE THE LOAD BY A LAYER FOR TRANSPORTATION WILL BE MADE BY THE RESPONSIBLE COMMAND AND WILL BE BASED UPON ECONOMICS OF TRANSPORTATION AND HANDLING.

**BILL OF MATERIAL**

PALLET, 40" X 48"	-----	1 REQD	-----	80 LBS
STEEL STRAPPING, 3/4" X 115.17'	-----	3 REQD	-----	8.23 LBS
SEAL FOR 3/4" STRAPPING	-----	7 REQD	-----	NIL

LATERAL PIECE, 2" X 4" X BOX HEIGHT MINUS 3" (4 REQD). NAIL TO VERTICAL PIECES W/2-10d NAILS AT EACH END AND TO CENTER SUPPORT PIECE W/2-10d NAILS.

VERTICAL PIECE, 2" X 4" X BOX WIDTH (4 REQD).

CENTER SUPPORT PIECE, 2" X 4" X BOX LENGTH MINUS 3" (1 REQD).

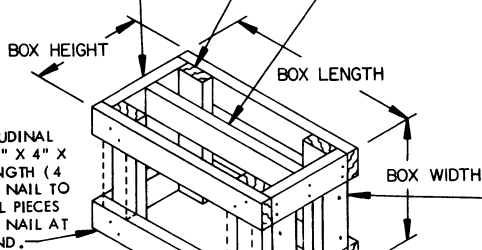

LONGITUDINAL PIECE, 2" X 4" X BOX LENGTH (4 REQD). NAIL TO VERTICAL PIECES W/2-10d NAIL AT EACH END.

FILL PIECE, 2" X 4" X CUT-TO-FIT (2 REQD). NAIL TO VERTICAL PIECE W/2-10d NAILS.

SUPPORT PIECE, 2" X 4" X CUT-TO-FIT (2 REQD). NAIL TO VERTICAL PIECE W/2-10d NAILS. NOTE: WHEN A UNIT HAS MORE THAN TEN BOXES OMITTED, THE FILLER ASSEMBLY OR ASSEMBLIES LOCATED IN AN OUTER STACK ON THE 48" SIDE OR SIDES OF THE PALLET WILL REQUIRE SUPPORT PIECES AS SHOWN.

**FILLER ASSEMBLY**  
(FOR MINUS ONE BOX)