

APPENDIX 26J

UNITIZATION PROCEDURES FOR BOXED AMMUNITION AND COMPONENTS ON 4-WAY ENTRY PALLETS

CARTRIDGE, 40MM, PACKED 32 PER WIREBOUND BOX,
UNITIZED 48 BOXES PER 35" X 45½" PALLET; APPROX
BOX SIZE 17⅝" L X 11¾" W X 8" H

PALLET UNIT DATA						
ITEMS INCLUDED		HAZARD CLASSIFICATION ①				WEIGHT (LBS)
NSN	DODIC	DOT CLASS	CG CLASS	QD CLASS	COMP GROUP	
1310- 00-935-9229	B537	C	XI-B	1.4	G	2,236
00-995-9230	B538	C	I	1.4	G	2,236

NOTICE: THIS APPENDIX CANNOT STAND ALONE BUT MUST
BE USED IN CONJUNCTION WITH THE BASIC UNITIZATION
PROCEDURES DRAWING 19-48-4116-20PA1002.

① HAZARD CLASSIFICATION DATA CONTAINED IN THE ABOVE CHART IS FOR GUIDANCE AND INFORMATIONAL PURPOSES ONLY. VERIFICATION OF THE SPECIFIED DATA SHOULD BE MADE BY CONSULTING THE MOST RECENT JOINT HAZARD CLASSIFICATION SYSTEM LISTING OR OTHER APPROVED LISTING(S).

DO NOT SCALE

REVISIONS																											
			<table border="1" style="width: 100%; border-collapse: collapse;"> <tr> <td style="font-size: small;">DRAFTSMAN B.L.</td> <td style="font-size: small;">PLOT/ENG <i>W.F. Bunt</i></td> </tr> <tr> <td style="font-size: small;">CHECKER <i>GRS</i></td> <td style="font-size: small;">LOG ENGINE OFFICE <i>W.F. Bunt</i></td> </tr> <tr> <td colspan="2" style="font-size: x-small;">APPROVES, U. S. ARMY ARMAMENT, MUNITIONS AND CHEMICAL COMMAND</td> </tr> <tr> <td style="text-align: center;"><i>[Signature]</i></td> <td style="text-align: center;"><i>[Signature]</i></td> </tr> <tr> <td colspan="2" style="font-size: x-small;">APPROVED BY ORDER OF COMMANDER GENERAL, U. S. ARMY MATERIEL DEVELOPMENT AND READINESS COMMAND (DARCOM)</td> </tr> <tr> <td colspan="2" style="text-align: center;"><i>[Signature]</i> U. S. ARMY DEFENSE AMMUNITION CENTER AND SCHOOL</td> </tr> <tr> <td colspan="2" style="text-align: center;">U. S. ARMY DARCOM DRAWING</td> </tr> <tr> <td colspan="2" style="text-align: center;">NOVEMBER 1983</td> </tr> <tr> <td style="font-size: x-small;">CLASS</td> <td style="font-size: x-small;">DIVISION</td> <td style="font-size: x-small;">DRAWING</td> <td style="font-size: x-small;">FILE</td> </tr> <tr> <td style="text-align: center;">19</td> <td style="text-align: center;">48</td> <td style="text-align: center;">4116/ 26J</td> <td style="text-align: center;">20PA 1002</td> </tr> </table>	DRAFTSMAN B.L.	PLOT/ENG <i>W.F. Bunt</i>	CHECKER <i>GRS</i>	LOG ENGINE OFFICE <i>W.F. Bunt</i>	APPROVES, U. S. ARMY ARMAMENT, MUNITIONS AND CHEMICAL COMMAND		<i>[Signature]</i>	<i>[Signature]</i>	APPROVED BY ORDER OF COMMANDER GENERAL, U. S. ARMY MATERIEL DEVELOPMENT AND READINESS COMMAND (DARCOM)		<i>[Signature]</i> U. S. ARMY DEFENSE AMMUNITION CENTER AND SCHOOL		U. S. ARMY DARCOM DRAWING		NOVEMBER 1983		CLASS	DIVISION	DRAWING	FILE	19	48	4116/ 26J	20PA 1002
DRAFTSMAN B.L.	PLOT/ENG <i>W.F. Bunt</i>																										
CHECKER <i>GRS</i>	LOG ENGINE OFFICE <i>W.F. Bunt</i>																										
APPROVES, U. S. ARMY ARMAMENT, MUNITIONS AND CHEMICAL COMMAND																											
<i>[Signature]</i>	<i>[Signature]</i>																										
APPROVED BY ORDER OF COMMANDER GENERAL, U. S. ARMY MATERIEL DEVELOPMENT AND READINESS COMMAND (DARCOM)																											
<i>[Signature]</i> U. S. ARMY DEFENSE AMMUNITION CENTER AND SCHOOL																											
U. S. ARMY DARCOM DRAWING																											
NOVEMBER 1983																											
CLASS	DIVISION	DRAWING	FILE																								
19	48	4116/ 26J	20PA 1002																								

GENERAL NOTES

- A. THIS APPENDIX CANNOT STAND ALONE BUT MUST BE USED IN CONJUNCTION WITH THE BASIC UNITIZATION PROCEDURES DRAWING 19-48-4116-20PA1002. TO PRODUCE AN APPROVED UNIT LOAD, ALL PERTINENT PROCEDURES, SPECIFICATIONS AND CRITERIA SET FORTH WITHIN THE BASIC DRAWING WILL APPLY TO THE PROCEDURES DELINEATED IN THIS APPENDIX. ANY EXCEPTIONS TO THE BASIC PROCEDURES ARE SPECIFIED IN THIS APPENDIX.
- B. DIMENSIONS, CUBE AND WEIGHT OF A PALLET UNIT WILL VARY SLIGHTLY DEPENDING UPON THE ACTUAL DIMENSIONS OF THE BOXES AND THE WEIGHT OF THE SPECIFIC ITEM BEING UNITIZED.
- C. INSTALL EACH HORIZONTAL STRAP TO ENCIRCLE A LAYER OF BOXES ON THE PALLET. NOTE THAT THE STRAPS WILL BE LOCATED AS DIMENSIONED, NEAR THE TOP OF EACH LAYER. HORIZONTAL STRAPS MUST BE TENSIONED AND SEALED PRIOR TO APPLICATION OF TIEDOWN STRAPS.
- D. INSTALL EACH TIEDOWN STRAP TO PASS UNDER THE TOP DECK BOARDS OF THE PALLET AND TO BE LOCATED AS SHOWN. TIEDOWN STRAPS WILL NOT BE APPLIED UNTIL THE HORIZONTAL STRAPS HAVE BEEN TENSIONED AND SEALED.
- E. THE FOLLOWING DARCOM DRAWINGS ARE APPLICABLE FOR OUTLOADING AND STORAGE OF THE ITEMS COVERED BY THIS APPENDIX.
 - CARLOADING----- DRAWING 19-48-4115-5PA1002
 - TRUCKLOADING---- DRAWING 19-48-4117-11PA1003
 - STORAGE----- DRAWING 19-48-4118-1-2-3-4-14-22PA1002
- F. FOR METHOD OF SECURING A STRAP CUTTER TO THE PALLET UNIT, SEE DARCOM DRAWING 19-48-4127-20P1000.
- G. IF ITEMS COVERED HEREIN ARE UNITIZED PRIOR TO ISSUANCE OF THIS APPENDIX, THE BOXES NEED NOT BE REUNITIZED SOLELY TO CONFORM TO THIS APPENDIX.
- H. THE UNITIZATION PROCEDURES DEPICTED HEREIN MAY ALSO BE USED FOR UNITIZING 40MM CARTRIDGES WHEN IDENTIFIED BY DIFFERENT NATIONAL STOCK NUMBERS (NSN) THAN WHAT IS SHOWN ON THE TITLE PAGE, PROVIDED THE BOX PACK DOES NOT VARY FROM WHAT IS DELINEATED HEREIN. THE EXPLOSIVE CLASSIFICATION OF OTHER ITEMS MAY BE DIFFERENT THAN WHAT IS SHOWN.
- J. WHEN THE UNIT LOAD DEPICTED AT LEFT IS TO BE USED FOR UNITIZING MARINE CORPS AMMUNITION, TWO LAYERS OF BOXES MUST BE OMITTED, TIEDOWN STRAP LENGTHS MUST BE DECREASED TO 12'-4", AND TWO HORIZONTAL STRAPS MUST BE OMITTED. THIS WILL RESULT IN AN OVERALL UNIT HEIGHT OF 37'-1/2", A GROSS UNIT WEIGHT OF 1,513 POUNDS, AND A UNIT CUBE OF 36.0 CUBIC FEET. ADDITIONALLY, THE UNIT LOAD MAY BE MODIFIED AS DESCRIBED WHEN BEING SHIPPED BY MILVAN OR COMMERCIAL INTERMODAL FREIGHT CONTAINER, CONVENTIONAL VAN TRAILER OR CONVENTIONAL OR HIGH-CAPACITY BOXCAR. THE DETERMINATION TO REDUCE THE LOAD BY LAYER(S) FOR TRANSPORTATION WILL BE MADE BY THE RESPONSIBLE COMMAND AND WILL BE BASED UPON ECONOMICS OF TRANSPORTATION AND HANDLING.

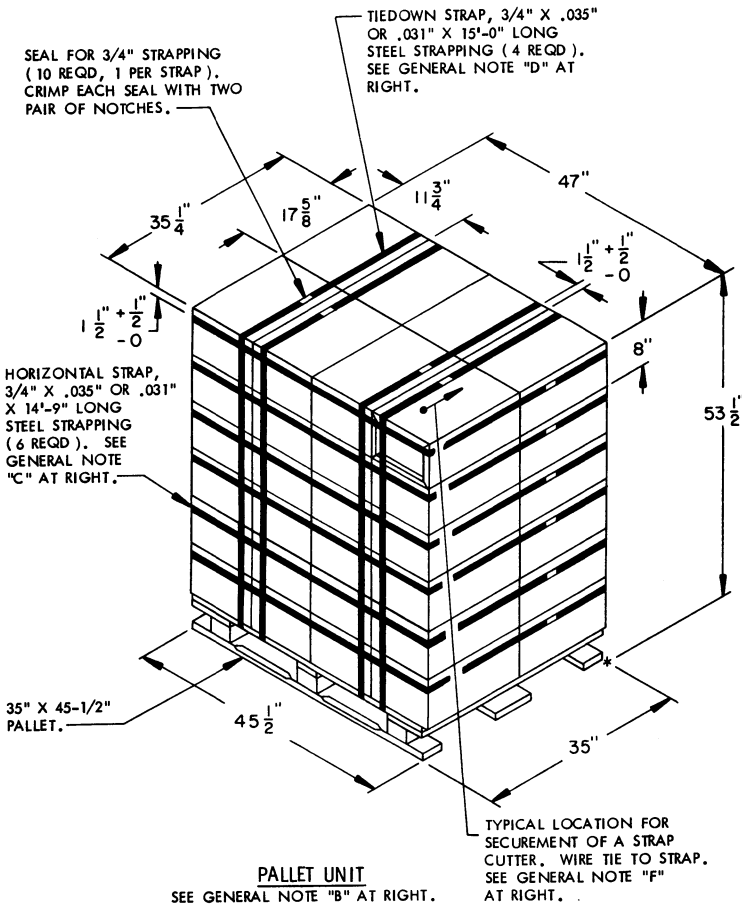

48 BOXES OF 40MM CARTRIDGE (32 PER BOX) @ 45 LBS-----	2,160 LBS (APPROX)
DUNNAGE -----	11 LBS
PALLET -----	65 LBS
TOTAL WEIGHT -----	2,236 LBS (APPROX)
CUBE -----	51.3 CU FT (APPROX)

BILL OF MATERIAL			
PALLET, 35" X 45-1/2" -----	1 REQD -----	65 LBS	
STEEL STRAPPING 3/4" -----	148.50' REQD -----	10.61 LBS	
SEAL FOR 3/4" STRAPPING -----	10 REQD -----	NIL	

