

APPENDIX 26E

UNITIZATION PROCEDURES FOR BOXED AMMUNITION AND COMPONENTS ON 4-WAY ENTRY PALLETS

CARTRIDGE, 40MM, PACKED 75 OR 100 PER
WOODEN BOX, UNITIZED 18 BOXES PER 35" X
45 ¹/₂" PALLET; APPROX BOX SIZE 22 ³/₄" L X 11 ¹/₁₆" W
X 11 ⁵/₈" H

PALLET UNIT DATA						
ITEMS INCLUDED		HAZARD CLASSIFICATION ①				WEIGHT
NSN	DODIC	DOT CLASS	CG CLASS	QD CLASS	COMP GROUP	(LBS)
1310-01-050-7967	B519	C	I	1.4	C	1,026
01-148-8881	B519	C	I	1.4	C	1,224

REVISION

REVISION NO. 1, DATED NOVEMBER 1983, CONSISTS OF:

1. CHANGING BOX DIMENSIONS.
2. CHANGING UNITIZATION PROCEDURES TO CONFORM TO 1.
3. ADDING ITEM BY NATIONAL STOCK NUMBER TO THE "PALLET UNIT DATA" CHART.

NOTICE: THIS APPENDIX CANNOT STAND ALONE BUT MUST BE USED IN CONJUNCTION WITH THE BASIC UNITIZATION PROCEDURES DRAWING 19-48-4116-20PA1002.

① HAZARD CLASSIFICATION DATA CONTAINED IN THE ABOVE CHART IS FOR GUIDANCE AND INFORMATIONAL PURPOSES ONLY. VERIFICATION OF THE SPECIFIED DATA SHOULD BE MADE BY CONSULTING THE MOST RECENT JOINT HAZARD CLASSIFICATION SYSTEM LISTING OR OTHER APPROVED LISTING(S).

DO NOT SCALE

REVISIONS				DRAFTSMAN PAB/roch	PROJ ENG J. H. W.
1	NOV 83	WFE	DRMC-LEP DRMC-TMD	RST	LOG ENGR OFFICE John R. Boyd
				APPROVED, U. S. ARMY ARMAMENT MATERIEL READINESS COMMAND	
				DRBAR - MAD DRBAR - TMD	
				APPROVED BY ORDER OF COMMANDING GENERAL, U. S. ARMY MATERIEL DEVELOPMENT AND READINESS COMMAND (DARCOM)	
				U. S. ARMY DEFENSE AMMUNITION CENTER AND SCHOOL	
				U. S. ARMY DARCOM DRAWING	
				MAY 1980	
		CLASS	DIVISION	DRAWING	FILE
		19	48	4116/ 26E	20PA 1002

LOAD STRAP, 3/4" X .035" OR .031" X 14'-3" LONG STEEL STRAPPING (3 REQD). SEE GENERAL NOTE "C" AT RIGHT.

SEAL FOR 3/4" STRAPPING (7 REQD, 1 PER STRAP). CRIMP EACH SEAL WITH TWO PAIR OF NOTCHES.

TIEDOWN STRAP, 3/4" X .035" OR .031" X 12'-5" LONG STEEL STRAPPING (4 REQD). SEE GENERAL NOTE "D" AT RIGHT.

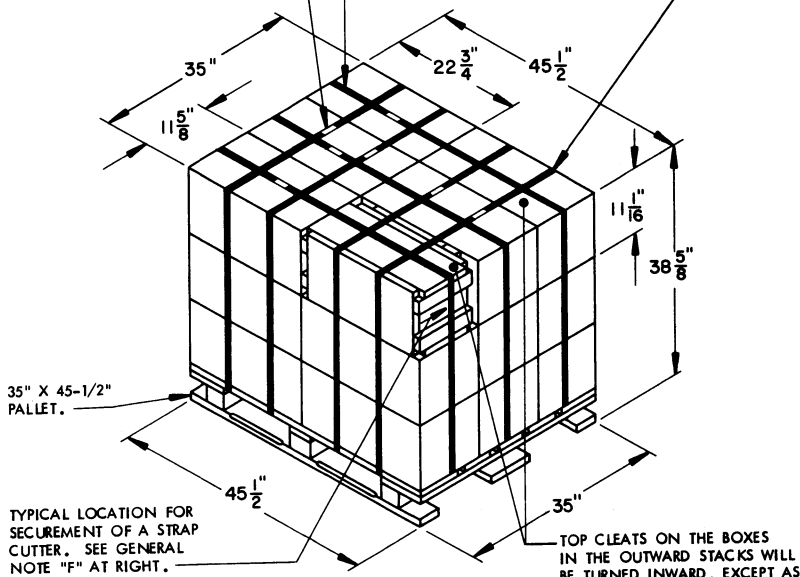

PALLET UNIT DATA

SEE GENERAL NOTE "B" AT RIGHT.

18 BOXES OF 40MM CARTRIDGE (75 PER BOX) @ 64 LBS	-----	1,152 LBS (APPROX)
DUNNAGE	-----	7 LBS
PALLET	-----	65 LBS
TOTAL WEIGHT	-----	1,224 LBS (APPROX)
CUBE	-----	35.5 CU FT (APPROX)

BILL OF MATERIAL

PALLET, 35" X 45-1/2"	-----	1 REQD	-----	65 LBS
STEEL STRAPPING	-----	92.42 REQD	-----	6.60 LBS
SEAL FOR 3/4" STRAPPING	-----	7 REQD	-----	NIL

END SUPPORT PIECE, 2" X 4" X BOX HEIGHT MINUS 6" (4 REQD).

VERTICAL PIECE, 2" X 4" X BOX WIDTH (4 REQD).

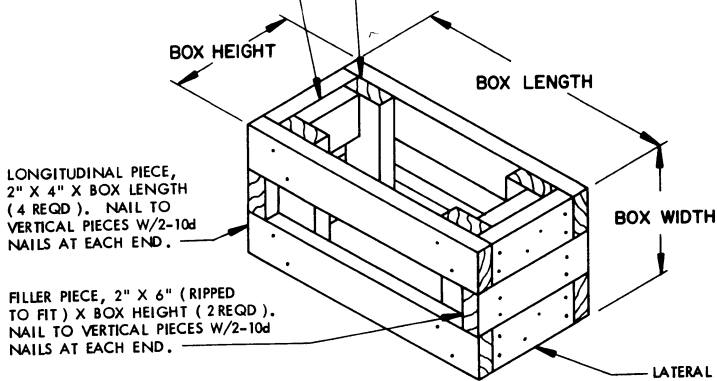

FILLER ASSEMBLY
(FOR MINUS ONE BOX)

LATERAL PIECE, 2" X 4" X BOX HEIGHT MINUS 3" (4 REQD). NAIL TO VERTICAL PIECES W/2-10d NAILS AT EACH END AND TO END SUPPORT PIECES W/2-10d NAILS.

GENERAL NOTES

- A. THIS APPENDIX CANNOT STAND ALONE BUT MUST BE USED IN CONJUNCTION WITH THE BASIC UNITIZATION PROCEDURES DRAWING 19-48-4116-20PA1002. TO PRODUCE AN APPROVED UNIT LOAD, ALL PERTINENT PROCEDURES, SPECIFICATIONS AND CRITERIA SET FORTH WITHIN THE BASIC DRAWING WILL APPLY TO THE PROCEDURES DELINEATED IN THIS APPENDIX. ANY EXCEPTIONS TO THE BASIC PROCEDURES ARE SPECIFIED IN THIS APPENDIX.
- B. DIMENSIONS, CUBE AND WEIGHT OF A PALLET UNIT WILL VARY SLIGHTLY DEPENDING UPON THE ACTUAL DIMENSIONS OF THE BOXES AND THE WEIGHT OF THE SPECIFIC ITEM BEING UNITIZED.
- C. THE LOAD STRAPS WILL BE PRE-POSITIONED ON THE PALLET DECK PRIOR TO PLACING BOXES ON THE PALLET. LOAD STRAPS MUST BE TENSIONED AND SEALED PRIOR TO APPLICATION OF TIEDOWN STRAPS.
- D. INSTALL EACH TIEDOWN STRAP TO PASS UNDER THE TOP DECK BOARDS OF THE PALLET AND TO BE LOCATED AS SHOWN. TIEDOWN STRAPS WILL NOT BE APPLIED UNTIL THE LOAD STRAPS HAVE BEEN TENSIONED AND SEALED.
- E. THE FOLLOWING DARCOM DRAWINGS ARE APPLICABLE FOR OUTLOADING AND STORAGE OF THE ITEMS COVERED BY THIS APPENDIX.

CARLOADING --- DRAWING 19-48-4115-5PA1002
TRUCKLOADING - DRAWING 19-48-4117-11PA1003
STORAGE----- DRAWING 19-48-4118-1-2-3-4-14-22PA1002
- F. FOR METHOD OF SECURING A STRAP CUTTER TO THE PALLET UNIT, SEE DARCOM DRAWING 19-48-4127-20P1000.
- G. IF ITEMS COVERED HEREIN ARE UNITIZED PRIOR TO ISSUANCE OF THIS APPENDIX, THE BOXES NEED NOT BE REUNITIZED SOLELY TO CONFORM TO THIS APPENDIX.
- H. THE UNITIZATION PROCEDURES DEPICTED HEREIN MAY ALSO BE USED FOR UNITIZING 40MM CARTRIDGES WHEN IDENTIFIED BY DIFFERENT NATIONAL STOCK NUMBERS (NSN) THAN WHAT IS SHOWN ON THE TITLE PAGE, PROVIDED THE BOX PACK DOES NOT VARY FROM WHAT IS DELINEATED HEREIN. THE EXPLOSIVE CLASSIFICATION OF OTHER ITEMS MAY BE DIFFERENT THAN WHAT IS SHOWN.