

APPENDIX 172

UNITIZATION PROCEDURES FOR BOXED AMMUNITION AND COMPONENTS ON 4-WAY ENTRY PALLETS

MASK, CHEMICAL-BIOLOGICAL, PROTECTIVE,
PACKED 8 PER CLEATED PLYWOOD BOX,
UNITIZED 4 BOXES PER 35" X 45-1/2"
PALLET; APPROX BOX SIZE 26-1/8" L X
25-7/8" W X 19-1/2" H

NOTICE: THIS APPENDIX CANNOT STAND ALONE BUT MUST BE USED IN CONJUNCTION WITH
THE BASIC UNITIZATION PROCEDURES DRAWING 19-48-4116-20PA1002.

DISTRIBUTION STATEMENT A.

APPROVED FOR PUBLIC RELEASE;
DISTRIBUTION IS UNLIMITED.

U. S. ARMY MATERIEL COMMAND DRAWING				
APPROVED, U.S. ARMY INDUSTRIAL OPERATIONS COMMAND <i>WH</i> <i>David L. Ashovich</i> AMSTA-AR-ESK	<i>David E. Stackwich</i> AMSIO-TMJ	DRAFTSMAN ENGINEER	BETTY J. KUNDERT SANDRA M. SCHULTZ	
APPROVED BY ORDER OF COMMANDING GENERAL, U.S. ARMY MATERIEL COMMAND <i>Larry V. Dilledge</i> U.S. ARMY DEFENSE AMMUNITION CENTER AND SCHOOL		SUPPLY ENGINEERING DIVISION <i>J. J. Wehler</i>	TRANSPORTATION ENGINEERING DIVISION <i>Laura A. Fuhr</i>	VALIDATION ENGINEERING DIVISION <i>J. J. Wehler</i>
		LOGISTICS ENGINEERING OFFICE <i>William F. Ernst</i>		
		MARCH 1988		
		CLASS	DIVISION	DRAWING
REVISION NO. 1	MAY 1996	19	48	4116/ 172
SEE THE REVISION LISTING ON PAGE 2				20PA 1002

DO NOT SCALE

PALLET UNIT DATA				
ITEMS INCLUDED		HAZARD CLASS AND DIVISION ●		APPROX WEIGHT LBS
NSN	DODIC	OD CLASS	COMP GROUP	
4240-				
01-258-0061	----		INERT	386
01-258-0062	----		INERT	386
01-258-0063	----		INERT	386
01-258-0064	----		INERT	386
01-258-0065	----		INERT	386
01-257-0066	----		INERT	386

● HAZARD CLASSIFICATION DATA CONTAINED IN THE ABOVE CHART IS FOR GUIDANCE AND INFORMATIONAL PURPOSES ONLY. VERIFICATION OF THE SPECIFIED DATA SHOULD BE MADE BY CONSULTING THE MOST RECENT JOINT HAZARD CLASSIFICATION SYSTEM LISTING OR OTHER APPROVED LISTING(S).

REVISION

REVISION NO. 1, DATED MAY 1996, CONSISTS OF:

1. CHANGING BOX SIZE.
2. DELETING GENERAL NOTE RELATING TO STRAP CUTTER AND RE-LETTERING OTHER GENERAL NOTES ACCORDINGLY.

GENERAL NOTES

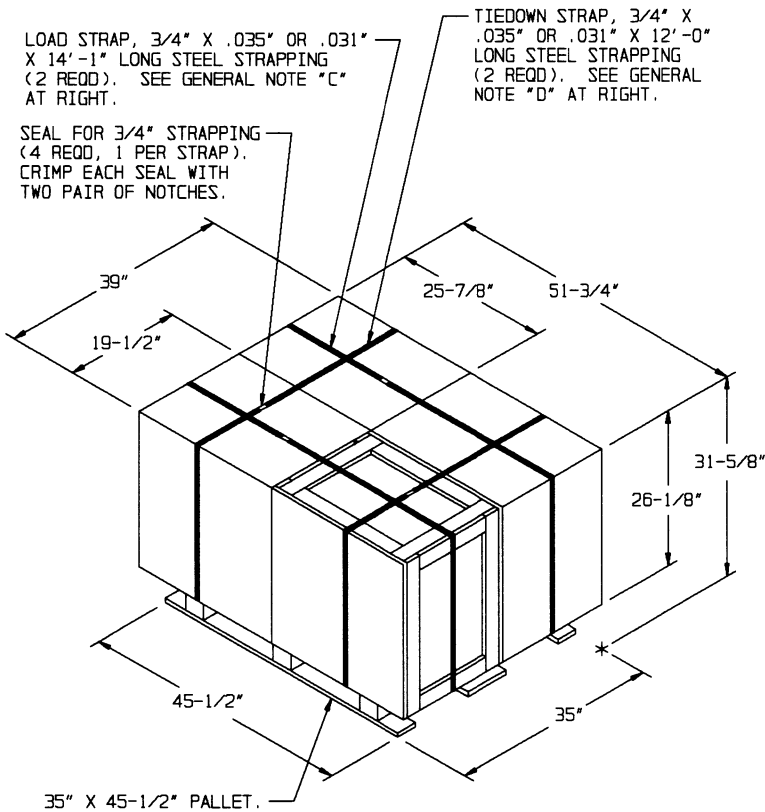

PALLET UNIT

SEE GENERAL NOTE "B" AT RIGHT.

4 BOXES OF MASKS (8 PER BOX) AT 79 LBS	-----	316 LBS (APPROX)
DUNNAGE	-----	5 LBS
PALLET	-----	65 LBS
<hr/>		
TOTAL WEIGHT	-----	386 LBS (APPROX)
CUBE	-----	36.9 CU FT (APPROX)

- A. THIS APPENDIX CANNOT STAND ALONE BUT MUST BE USED IN CONJUNCTION WITH THE BASIC UNITIZATION PROCEDURES DRAWING 19-48-4116-20PA1002. TO PRODUCE AN APPROVED UNIT LOAD, ALL PERTINENT PROCEDURES, SPECIFICATIONS AND CRITERIA SET FORTH WITHIN THE BASIC DRAWING WILL APPLY TO THE PROCEDURES DELINEATED IN THIS APPENDIX. ANY EXCEPTIONS TO THE BASIC PROCEDURES ARE SPECIFIED IN THIS APPENDIX.
- B. DIMENSIONS, CUBE AND WEIGHT OF A PALLET UNIT WILL VARY SLIGHTLY DEPENDING UPON THE ACTUAL DIMENSIONS OF THE BOXES AND THE WEIGHT OF THE SPECIFIC ITEM BEING UNITIZED.
- C. THE LOAD STRAPS MAY BE THREADED THROUGH THE STRAP SLOTS OF A PALLET OR PRE-POSITIONED ON THE PALLET DECK PRIOR TO PLACING BOXES ON THE PALLET. LOAD STRAPS MUST BE TENSIONED AND SEALED PRIOR TO APPLICATION OF TIEDOWN STRAPS.
- D. INSTALL EACH TIEDOWN STRAP TO PASS UNDER THE TOP DECK BOARDS OF THE PALLET. TIEDOWN STRAPS WILL NOT BE APPLIED UNTIL THE LOAD STRAPS HAVE BEEN TENSIONED AND SEALED.
- E. THE FOLLOWING AMC DRAWINGS ARE APPLICABLE FOR OUTLOADING AND STORAGE OF THE ITEMS COVERED BY THIS APPENDIX.
 - CARLOADING - - - - 19-48-4115-5PA1002
 - TRUCKLOADING - - - - 19-48-4117-11PA1003
 - STORAGE - - - - - 19-48-4118-1-2-3-4-14-22PA1002
 - END OPENING ISO
 - CONTAINER - - - - - 19-48-4153-15PA1002
 - MILVAN - - - - - 19-48-4166-15PA1003
 - SIDE OPENING ISO
 - CONTAINER - - - - - 19-48-4267-15PA1009
- F. IF ITEMS COVERED HEREIN ARE UNITIZED PRIOR TO ISSUANCE OF THIS APPENDIX, THE BOXES NEED NOT BE REUNITIZED SOLELY TO CONFORM TO THIS APPENDIX.
- G. THE UNITIZATION PROCEDURES DEPICTED HEREIN MAY ALSO BE USED FOR UNITIZING MASKS WHEN IDENTIFIED BY DIFFERENT NATIONAL STOCK NUMBERS (NSN) THAN WHAT IS SHOWN ON PAGE 2, PROVIDED THE BOX PACK DOES NOT VARY FROM WHAT IS DELINEATED HEREIN. THE EXPLOSIVE CLASSIFICATION OF OTHER ITEMS MAY BE DIFFERENT THAN WHAT IS SHOWN.
- H. THE STYLE 1A PALLET DELINEATED IN THE DETAIL AT LEFT NEED NOT HAVE CHAMFERS OR STRAP SLOTS AS SPECIFIED WITHIN MILITARY SPECIFICATION MIL-P-15011 WHEN USED FOR THE UNITIZATION OF ITEMS COVERED BY THIS APPENDIX.
- J. THE 51-3/4" LENGTH DIMENSION IS AN EXCEPTION TO THE BASIC PROCEDURES. HOWEVER, THE EXCEPTION IS NECESSARY FOR THE AMMUNITION PACK COVERED BY THIS APPENDIX, TO MOST EFFECTIVELY GET AN ACCEPTABLE, COMPACT AND SOUND PALLET UNIT.

BILL OF MATERIAL

PALLET, 35" X 45-1/2"	- - - 1 REQD	-----	65 LBS
STEEL STRAPPING, 3/4"	- 52.17' REQD	-----	4.66 LBS
SEAL FOR 3/4" STRAPPING	- - 4 REQD	-----	NIL

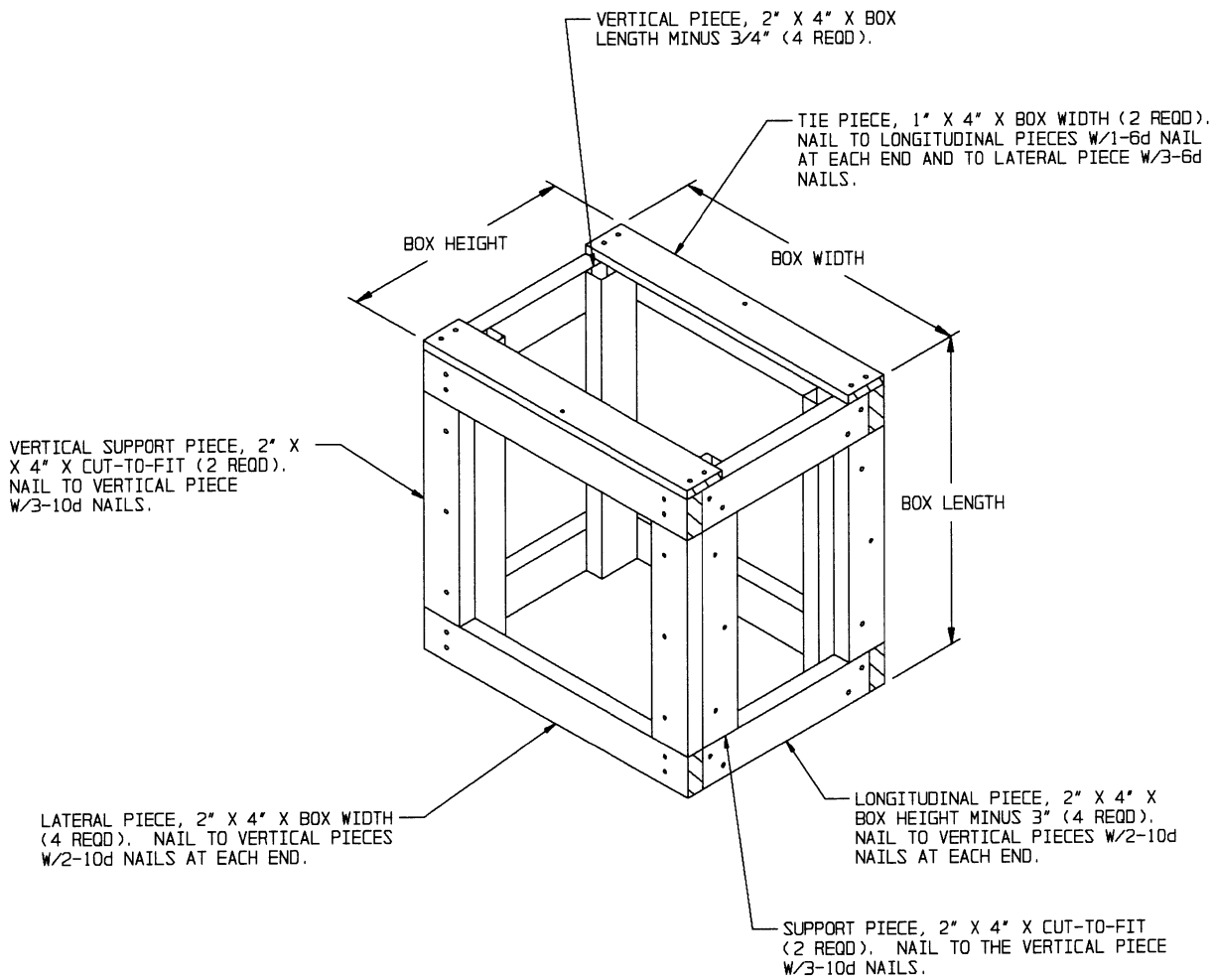

FILLER ASSEMBLY
(FOR MINUS ONE BOX)