

APPENDIX 17

UNITIZATION PROCEDURES FOR BOXED AMMUNITION AND COMPONENTS ON 4-WAY ENTRY PALLETS

25MM CARTRIDGE, PACKED 30 PER M621 SHIPPING
AND STORAGE CONTAINER, UNITIZED 27
CONTAINERS PER 42" X 53" PALLET; APPROX
BOX SIZE 13-3/4" L X 5-5/8" W X 14-3/8" H

NOTICE: THIS APPENDIX CANNOT STAND ALONE BUT MUST BE USED IN CONJUNCTION WITH
THE BASIC UNITIZATION PROCEDURES DRAWING 19-48-4116-20PA1002.

DISTRIBUTION STATEMENT A.

APPROVED FOR PUBLIC RELEASE:
DISTRIBUTION IS UNLIMITED.

U. S. ARMY MATERIEL COMMAND DRAWING			
APPROVED, U.S. ARMY ARMAMENT, MUNITIONS AND CHEMICAL COMMAND <i>David A. Piskoun</i> <i>Timothy Ford</i> SMCAR-ESK AMSMC-TMG	DRAFTSMAN	INGEBORG DEPPE	
	ENGINEER	SANDRA M. SCHULTZ	
	SUPPLY ENGINEERING DIVISION	TRANSPORTATION ENGINEERING DIVISION	VALIDATION ENGINEERING DIVISION
	<i>J. J. Michel</i>	<i>W. Smith</i>	<i>...</i>
APPROVED BY ORDER OF COMMANDING GENERAL, U.S. ARMY MATERIEL COMMAND <i>John L. Beard, P.E.</i>	LOGISTICS ENGINEERING OFFICE <i>William J. Ernst</i>		
	NOVEMBER 1989		
U. S. ARMY DEFENSE AMMUNITION CENTER AND SCHOOL	CLASS	DIVISION	DRAWING
REVISION NO. 5	AUGUST 1994	19	48
SEE THE REVISION LISTING ON PAGE 2		4116/ 17	20PA 1002

DO NOT SCALE

PALLET UNIT DATA				
ITEMS INCLUDED		HAZARD CLASS AND DIVISION		APPROX WEIGHT LBS
NSN	DODIC	OD CLASS	COMP GROUP	
1305-				
01-286-5185	A940	(08)1.2	C	1,056
01-105-4095	A967	INERT		1,515
01-092-0428	A974	1.4	C	1,515
01-094-1035	A975	(04)1.2	E	1,515
01-092-0429	A976	1.4	C	1,515
01-304-9977	A986	(04)1.2	C	1,515

● HAZARD CLASSIFICATION DATA CONTAINED IN THE ABOVE CHART IS FOR GUIDANCE AND INFORMATIONAL PURPOSES ONLY. VERIFICATION OF THE SPECIFIED DATA SHOULD BE MADE BY CONSULTING THE MOST RECENT JOINT HAZARD CLASSIFICATION SYSTEM LISTING OR OTHER APPROVED LISTING(S).

REVISIONS

REVISION NO. 1, DATED JULY 1982, CONSISTS OF:

1. ADDING ITEMS BY NATIONAL STOCK NUMBER IN THE "PALLET UNIT DATA" CHART.

REVISION NO. 2, DATED APRIL 1984, CONSISTS OF:

1. ADDING GENERAL NOTES FOR MARKING OF PALLET DUNNAGE.
2. ADDING HAZARD CLASSIFICATION NOTE.

REVISION NO. 3, DATED NOVEMBER 1989, CONSISTS OF:

1. ADDING ITEM BY NATIONAL STOCK NUMBER TO THE "PALLET UNIT DATA" CHART.
2. ADDING DOT PROPER SHIPPING NAMES TO THE "PALLET UNIT DATA" CHART.
3. REVISING NOTES "J" AND "K".
4. DELETING NOTE "L".

REVISION NO. 4, DATED JULY 1992, CONSISTS OF:

1. ADDING ITEM BY NATIONAL STOCK NUMBER TO THE "PALLET UNIT DATA" CHART.

REVISION NO. 5, DATED AUGUST 1994, CONSISTS OF:

1. ADDING HAZARD CLASSIFICATION TO ITEM IN THE "PALLET UNIT DATA" CHART.

GENERAL NOTES

- A. THIS APPENDIX CANNOT STAND ALONE BUT MUST BE USED IN CONJUNCTION WITH THE BASIC UNITIZATION PROCEDURES DRAWING 19-48-4116-20PA1002. TO PRODUCE AN APPROVED UNIT LOAD, ALL PERTINENT PROCEDURES, SPECIFICATIONS AND CRITERIA SET FORTH WITHIN THE BASIC DRAWING WILL APPLY TO THE PROCEDURES DELINEATED IN THIS APPENDIX. ANY EXCEPTIONS TO THE BASIC PROCEDURES ARE SPECIFIED IN THIS APPENDIX.
- B. DIMENSIONS, CUBE AND WEIGHT OF A PALLET UNIT WILL VARY SLIGHTLY DEPENDING UPON THE ACTUAL DIMENSIONS OF THE BOXES AND THE WEIGHT OF THE SPECIFIC ITEM BEING UNITIZED.
- C. INSTALL EACH HORIZONTAL STRAP TO ENCIRCLE THE DUNNAGE ASSEMBLIES. HORIZONTAL STRAPS MUST BE TENSIONED AND SEALED PRIOR TO APPLICATION OF TIEDOWN STRAPS.
- D. INSTALL EACH TIEDOWN STRAP TO PASS UNDER THE TOP DECK BOARDS OF THE PALLET. TIEDOWN STRAPS WILL NOT BE APPLIED UNTIL THE HORIZONTAL STRAPS HAVE BEEN TENSIONED AND SEALED.
- E. THE FOLLOWING AMC DRAWINGS ARE APPLICABLE FOR OUTLOADING AND STORAGE OF THE ITEMS COVERED BY THIS APPENDIX.
 - CARLOADING - - - - 19-48-4115-5PA1002
 - TRUCKLOADING - - - - 19-48-4117-11PA1003
 - STORAGE - - - - 19-48-4118-1-2-3-4-14-22PA1002
 - END OPENING ISO CONTAINER - - - - 19-48-4153-15PA1002
 - MILVAN - - - - 19-48-4166-15PA1003
 - SIDE OPENING ISO CONTAINER - - - - 19-48-4267-15PA1009
- F. FOR METHOD OF SECURING A STRAP CUTTER TO THE PALLET UNIT, SEE AMC DRAWING 19-48-4127-20P1000.
- G. IF ITEMS COVERED HEREIN ARE UNITIZED PRIOR TO ISSUANCE OF THIS APPENDIX, THE BOXES NEED NOT BE REUNITIZED SOLELY TO CONFORM TO THIS APPENDIX.
- H. THE UNITIZATION PROCEDURES DEPICTED HEREIN MAY ALSO BE USED FOR UNITIZING 25MM CARTRIDGES WHEN IDENTIFIED BY DIFFERENT NATIONAL STOCK NUMBERS (NSN) THAN WHAT IS SHOWN ON PAGE 2, PROVIDED THE CONTAINER DOES NOT VARY FROM WHAT IS DELINEATED HEREIN. THE EXPLOSIVE CLASSIFICATION OF OTHER ITEMS MAY BE DIFFERENT THAN WHAT IS SHOWN.
- J. THIS PALLETIZATION PROCEDURE IS THE OUTER SHIPPING CONTAINER FOR PACKAGING M621 PLASTIC CONTAINERS. THE OUTER DUNNAGE MUST BE MARKED IN ACCORDANCE WITH MIL-STD-129 AND DRAWING 8796522, WITH 1/4-INCH MINIMUM LETTERING, EXCEPT THAT LOT AND DODIC MARKING ON ENDS OF THE BOX MAY BE IN THE HORIZONTAL DIRECTION AND PROPER SHIPPING NAME ON TOP OF THE BOX WILL BE IN 1/2-INCH LETTER SIZE (MIN).
- K. THIS PACKAGE IS CERTIFIED UNDER AMCCOM COE IN ACCORDANCE WITH 49 CFR173.7A AND DARCOM R700.103-CCN-84 061 APPLIES. UNDER THE REQUIREMENTS OF THIS COE, THE DRAWING NUMBER 19-48-4116/17-20PA1002 MUST WILL BE MARKED CLEARLY ON THE OUTER DUNNAGE SO AS NOT TO INTERFERE WITH OTHER MARKINGS. MINIMUM MARKING IS NSN, NOMENCLATURE, LOT NO. (UNDERLINED), GROSS WT. ON FRONT SIDE OF DUNNAGE, DODIC AND LOT NUMBER ON EACH END OF UNIT, AND PROPER SHIPPING NAME ON TOP DUNNAGE.
- L. THE STYLE 1B PALLET DELINEATED IN THE DETAIL AT LEFT NEED NOT HAVE CHAMFERS OR STRAP SLOTS AS SPECIFIED WITHIN MILITARY SPECIFICATION MIL-P-15011 WHEN USED FOR THE UNITIZATION OF ITEMS COVERED BY THIS APPENDIX.

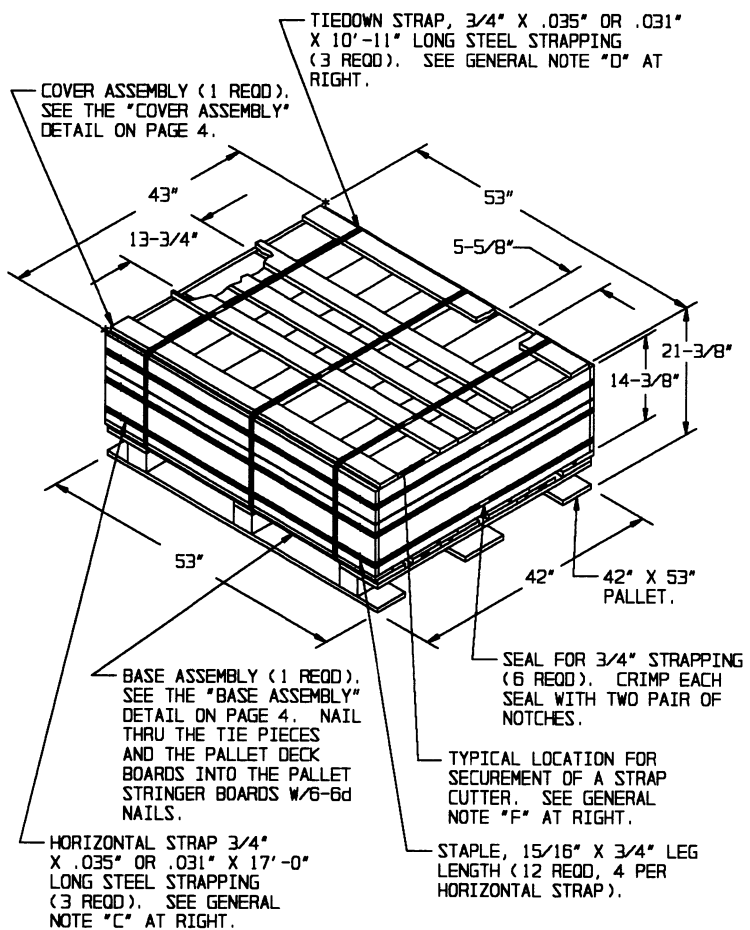

PALLET UNIT

SEE GENERAL NOTE "B" AT RIGHT.

27 CNTRS OF 25MM CTG (30 PER CONTAINER) @ 50 LBS	-	1,350 LBS (APPROX)
DUNNAGE	-	75 LBS
PALLET	-	90 LBS

TOTAL WEIGHT	-	1,515 LBS (APPROX)
CUBE	-	28.2 CU FT (APPROX)

BILL OF MATERIAL		
LUMBER	LINEAR FEET	BOARD FEET
1" X 4"	39.75	13.25
1" X 6"	15.75	7.88
1" X 10"	15.75	13.13
NAILS	NO. REOD	POUNDS
6d (2")	62	0.36

PALLET, 42" X 53"	-	1 REOD	-	90 LBS
STEEL STRAPPING, 3/4"	-	83.75' REOD	-	5.98 LBS
SEAL FOR 3/4" STRAPPING	-	6 REOD	-	NIL

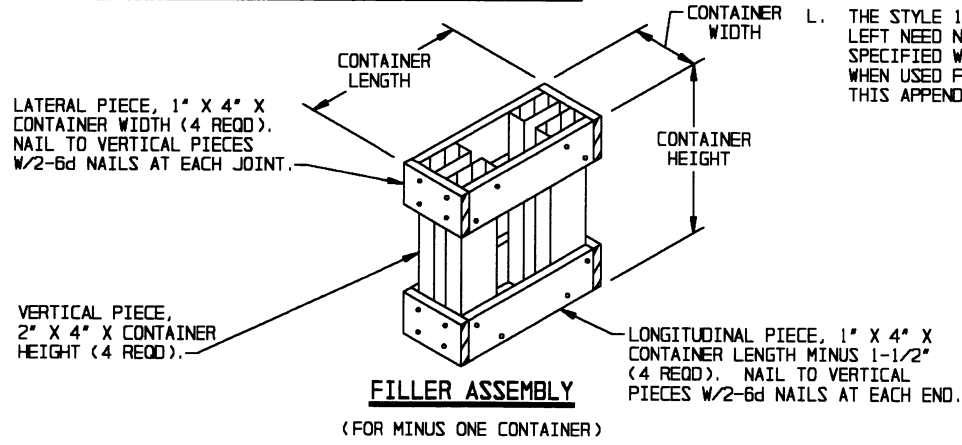

FILLER ASSEMBLY

(FOR MINUS ONE CONTAINER)

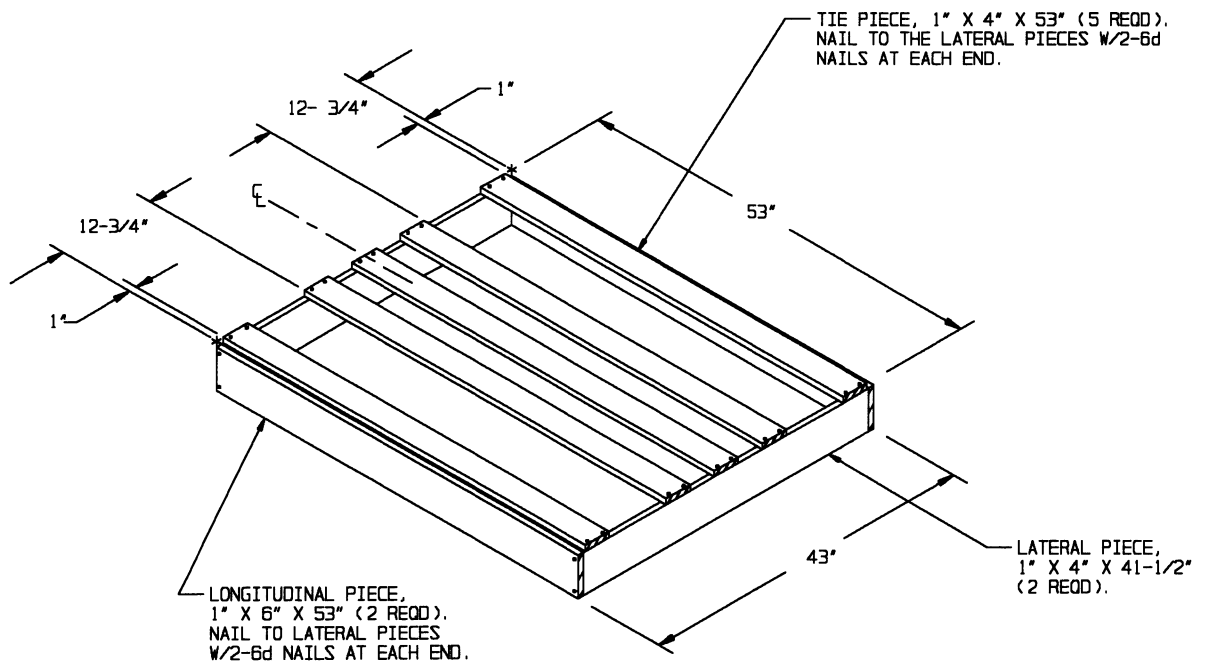

COVER ASSEMBLY

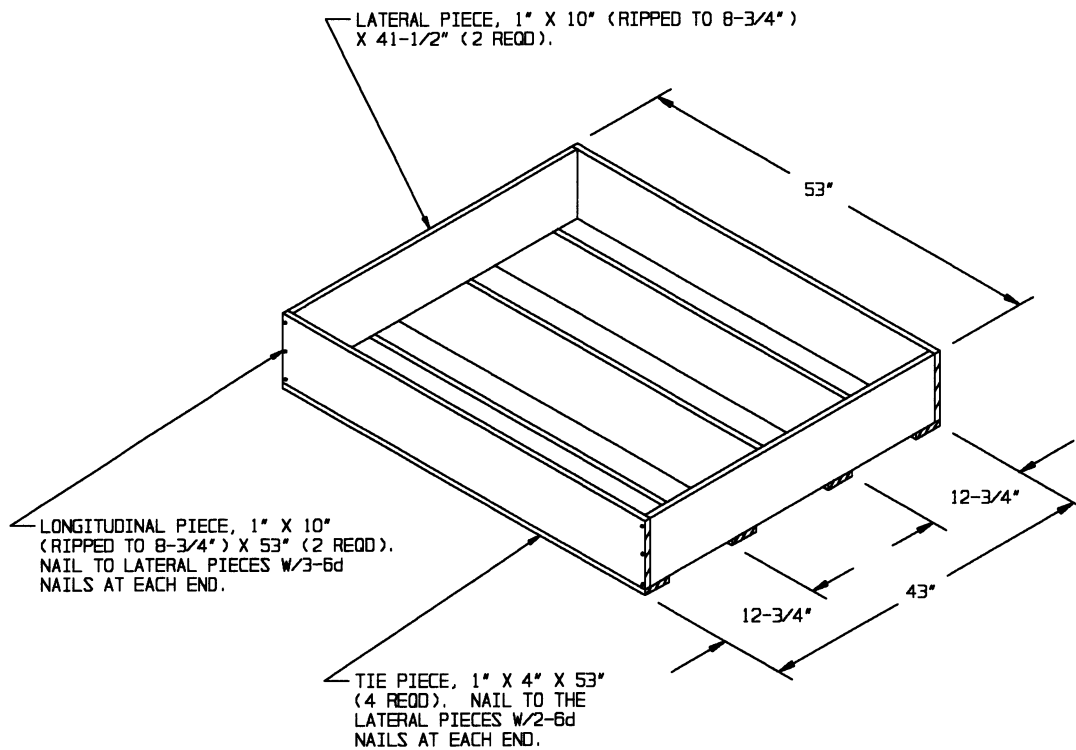

BASE ASSEMBLY