

APPENDIX 162A

UNITIZATION PROCEDURES FOR BOXED AMMUNITION AND COMPONENTS ON 4-WAY ENTRY PALLETS

AGENT, DECONTAMINATING, DS2, PACKED IN 5-GAL
PAIL, UNITIZED 24 PAILS PER 35" X 45-1/2"
PALLET; PAIL SIZE 11-3/8" DIA X 13-1/2" H

NOTICE: THIS APPENDIX CANNOT STAND ALONE BUT MUST BE USED IN CONJUNCTION WITH
THE BASIC UNITIZATION PROCEDURES DRAWING 19-48-4116-20PA1002.

U.S. ARMY MATERIEL COMMAND DRAWING			
APPROVED, U.S. ARMY ARMAMENT, MUNITIONS AND CHEMICAL COMMAND <i>mjr</i> <i>David A. Pichault</i> SMCAR-ESK	DRAFTSMAN D. WHITMORE ENGINEER SANDRA M. SCHULTZ		
<i>David E. Hawick</i> AMSMC-TMD	SUPPLY ENGINEERING DIVISION <i>W F Ernst</i>	TRANSPORTATION ENGINEERING DIVISION <i>J. Simons</i>	VALIDATION ENGINEERING DIVISION <i>Amel...sch</i>
APPROVED BY ORDER OF COMMANDING GENERAL, U.S. ARMY MATERIEL COMMAND <i>William L. B...y</i> U.S. ARMY DEFENSE AMMUNITION CENTER AND SCHOOL	LOGISTICS ENGINEERING OFFICE <i>William F Ernst</i> AUGUST 1983		
REVISION NO. 1	MARCH 1992	CLASS 19	DIVISION 48
SEE THE REVISION LISTING ON PAGE 2		DRAWING 4116/ 162A	FILE 20PA 1002

DO NOT SCALE

PALLET UNIT DATA					
ITEMS INCLUDED		HAZARD CLASSIFICATION ●			APPROX WEIGHT LBS
NSN	DODIC	CG CLASS	HAZARD CLASS AND DIVISION		
			OD CLASS	COMP GROUP	
6850- 00-753-4870			—CORROSIVE—		1,256

- HAZARD CLASSIFICATION DATA CONTAINED IN THE ABOVE CHART IS FOR GUIDANCE AND INFORMATIONAL PURPOSES ONLY. VERIFICATION OF THE SPECIFIED DATA SHOULD BE MADE BY CONSULTING THE MOST RECENT HAZARDOUS COMPONENT SAFETY DATA STATEMENT 20059 OR THE APPROVED PACKAGING DRAWING.

REVISION

REVISION NO. 1, DATED MARCH 1992, CONSISTS OF:

1. ADDING INTERMEDIATE DUNNAGE ASSEMBLY.
2. ADDING LOAD STRAPS.
3. UPDATING NOTES AND WEIGHTS.

GENERAL NOTES

- A. THIS APPENDIX CANNOT STAND ALONE BUT MUST BE USED IN CONJUNCTION WITH THE BASIC UNITIZATION PROCEDURES DRAWING 19-48-4116-20PA1002. TO PRODUCE AN APPROVED UNIT LOAD, ALL PERTINENT PROCEDURES, SPECIFICATIONS AND CRITERIA SET FORTH WITHIN THE BASIC DRAWING WILL APPLY TO THE PROCEDURES DELINEATED IN THIS APPENDIX. ANY EXCEPTIONS TO THE BASIC PROCEDURES ARE SPECIFIED IN THIS APPENDIX.
- B. DIMENSIONS, CUBE AND WEIGHT OF A PALLET UNIT WILL VARY SLIGHTLY DEPENDING UPON THE ACTUAL DIMENSIONS OF THE PAILS AND THE WEIGHT OF THE SPECIFIC ITEM BEING UNITIZED.
- C. INSTALL EACH HORIZONTAL STRAP TO ENCIRCLE A DUNNAGE ASSEMBLY. HORIZONTAL STRAPS MUST BE TENSIONED AND SEALED PRIOR TO THE APPLICATION OF TIEDOWN AND LOAD STRAPS.
- D. INSTALL EACH TIEDOWN STRAP TO PASS UNDER THE TOP DECK BOARDS OF THE PALLET. NOTE THAT THE STRAPS WILL BE LOCATED AS SHOWN. TIEDOWN STRAPS WILL NOT BE APPLIED UNTIL THE HORIZONTAL AND LOAD STRAPS HAVE BEEN TENSIONED AND SEALED.
- E. THE FOLLOWING AMC DRAWINGS ARE APPLICABLE FOR OVLADING AND STORAGE OF THE ITEMS COVERED BY THIS APPENDIX.
 - CARLOADING - - - - 19-48-4115-5PA1002
 - TRUCKLOADING - - - 19-48-4117-11PA1003
 - STORAGE - - - - - 19-48-4118-1-2-3-4-14-22PA1002
 - COMMERCIAL CONTAINER - - - - 19-48-4153-15PA1002
 - MILVAN - - - - - 19-48-4166-15PA1003
- F. FOR METHOD OF SECURING A STRAP CUTTER TO THE PALLET UNIT, SEE AMC DRAWING 19-48-4127-20P1000.
- G. IF ITEMS COVERED HEREIN ARE UNITIZED PRIOR TO ISSUANCE OF THIS APPENDIX, THE PAILS NEED NOT BE REUNITIZED SOLELY TO CONFORM TO THIS APPENDIX.
- H. THE UNITIZATION PROCEDURES DEPICTED HEREIN MAY ALSO BE USED FOR UNITIZING DECONTAMINATING AGENT WHEN IDENTIFIED BY DIFFERENT NATIONAL STOCK NUMBERS (NSN) THAN WHAT IS SHOWN ON PAGE 2, PROVIDED THE PAIL DOES NOT VARY FROM WHAT IS DELINEATED HEREIN. THE HAZARD CLASSIFICATION OF OTHER ITEMS MAY BE DIFFERENT THAN WHAT IS SHOWN.
- J. NOTICE: THE PAILS MUST BE ORIENTED IN SUCH A MANNER THAT AT LEAST ONE PRECAUTIONARY HANDLING LABEL AFFIXED TO A PAIL IS VISIBLE FROM EACH OF THE FOUR SIDES OF THE UNIT LOAD.
- K. THE STYLE 1A PALLET DELINEATED IN THE DETAIL AT LEFT NEED NOT HAVE CHAMFERS OR STRAP SLOTS AS SPECIFIED WITHIN MILITARY SPECIFICATION MIL-P-15011 WHEN USED FOR THE UNITIZATION OF ITEMS COVERED BY THIS APPENDIX.

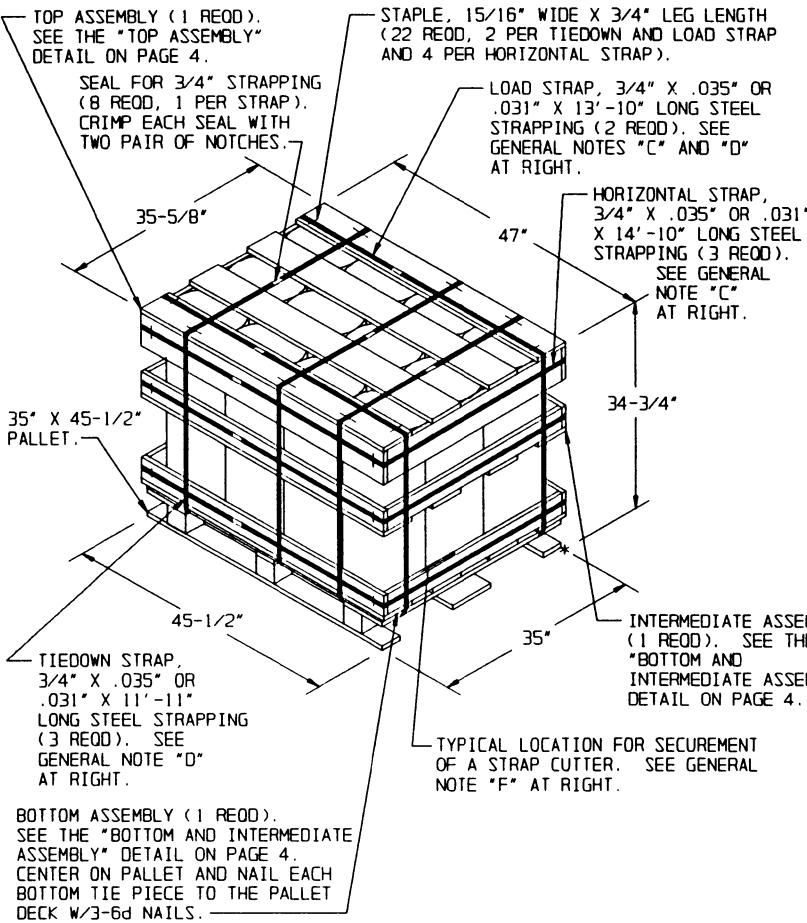

PALLET UNIT

SEE GENERAL NOTE "B" AT RIGHT.

24 PAILS OF DECONTAMINATING AGENT (5 GAL PAIL) @ 46 LBS - 1,104 LBS (APPROX)
 DUNNAGE - - - - - 87 LBS
 PALLET - - - - - 65 LBS

TOTAL WEIGHT - - - - - 1,256 LBS (APPROX)
 CUBE - - - - - 33.67 CU FT (APPROX)

BILL OF MATERIAL		
LUMBER	LINEAR FEET	BOARD FEET
1" X 4"	27.04	9.01
1" X 6"	60.52	30.26
NAILS	NO. REOD	POUNDS
6d (2")	130	0.76
PALLET, 35" X 45-1/2" - - - - 1 REOD - - - - 65 LBS		
STEEL STRAPPING, 3/4" - 107.90' REOD - - - - 7.68 LBS		
SEAL FOR 3/4" STRAPPING - - 8 REOD - - - - NIL		
STAPLE, 15/16" X 3/4" - - 22 REOD - - - - NIL		

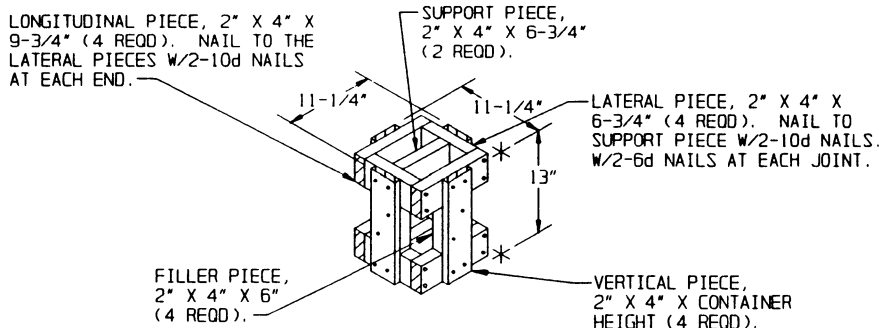

FILLER ASSEMBLY

(FOR MINUS ONE CONTAINER)

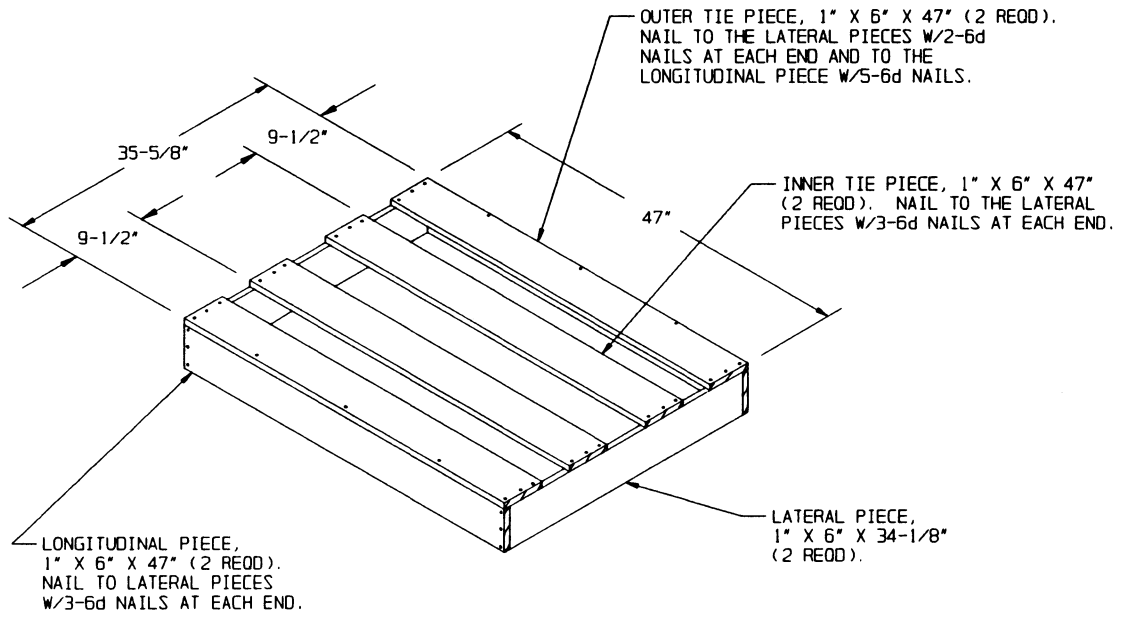

TOP ASSEMBLY
(1 REOD)

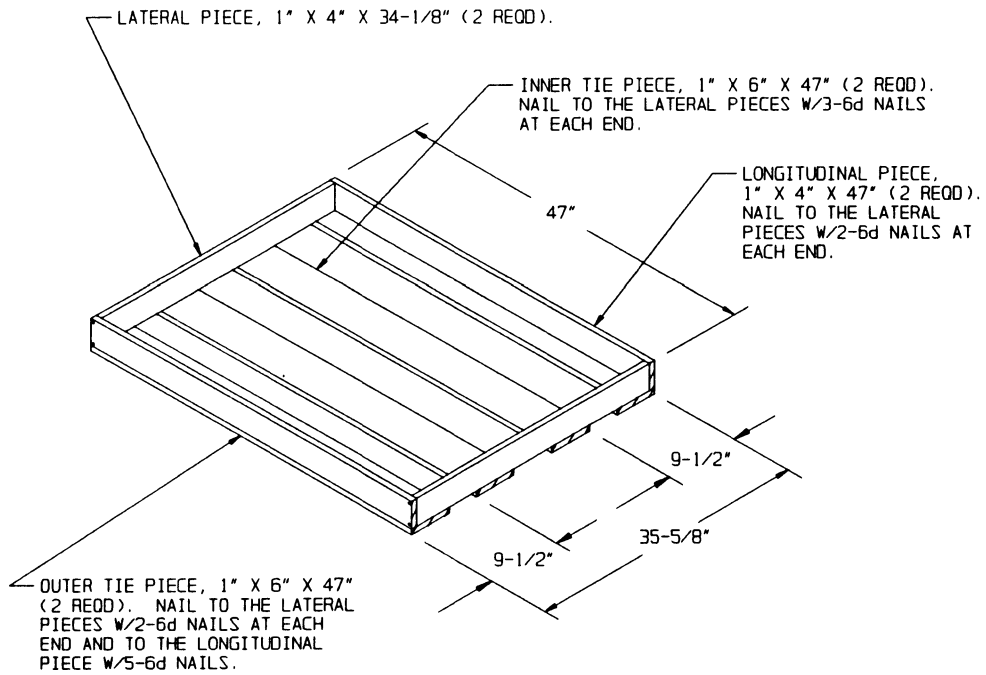

BOTTOM AND INTERMEDIATE ASSEMBLY
(1 EACH REOD)