

APPENDIX 158D

UNITIZATION PROCEDURES FOR BOXED AMMUNITION AND COMPONENTS ON 4-WAY ENTRY PALLETS

PRIMER, PERCUSSION, PACKED 200 PER WOODEN
BOX, UNITIZED 24 BOXES PER 35" X 45-1/2"
PALLET; APPROX BOX SIZE 17-1/4" L X
12-5/8" W X 9-3/4" H

NOTICE: THIS APPENDIX CANNOT STAND ALONE BUT MUST BE USED IN CONJUNCTION WITH
THE BASIC UNITIZATION PROCEDURES DRAWING 19-48-4116-20PA1002.

DISTRIBUTION STATEMENT A.

APPROVED FOR PUBLIC RELEASE;
DISTRIBUTION IS UNLIMITED.

U. S. ARMY MATERIEL COMMAND DRAWING			
APPROVED, U. S. ARMY ARMAMENT, MUNITIONS AND CHEMICAL COMMAND <i>NLH</i> <i>David O. ...</i> SMCAR-ESK	ENGINEER SANDRA M. SCHULTZ	DRAFTSMAN D. WHITMORE	ENGINEER SANDRA M. SCHULTZ
APPROVED BY ORDER OF COMMANDING GENERAL, U. S. ARMY MATERIEL COMMAND <i>William L. ...</i> U. S. ARMY DEFENSE AMMUNITION CENTER AND SCHOOL	SUPPLY ENGINEERING DIVISION <i>S. Schultz</i>	TRANSPORTATION ENGINEERING DIVISION <i>W. ...</i>	VALIDATION ENGINEERING DIVISION <i>...</i>
APPROVED BY ORDER OF COMMANDING GENERAL, U. S. ARMY MATERIEL COMMAND <i>William L. ...</i> U. S. ARMY DEFENSE AMMUNITION CENTER AND SCHOOL		LOGISTICS ENGINEERING OFFICE <i>William F. Ernst</i>	
DECEMBER 1980			
REVISION NO. 1	AUGUST 1994	CLASS	DIVISION
SEE THE REVISION LISTING ON PAGE 2	19	48	DRAWING
		4116/ 158D	FILE
			20PA 1002

DO NOT SCALE

PALLET UNIT DATA				
ITEMS INCLUDED		HAZARD CLASS AND DIVISION ●		APPROX WEIGHT LBS
NSN	DODIC	OD CLASS	COMP GROUP	
1390-00-151-2556	N518	1.4	G	2,134
00-825-1370	N518	1.4	G	2,134
00-857-2955	N558	1.4	G	2,134

● HAZARD CLASSIFICATION DATA CONTAINED IN THE ABOVE CHART IS FOR GUIDANCE AND INFORMATIONAL PURPOSES ONLY. VERIFICATION OF THE SPECIFIED DATA SHOULD BE MADE BY CONSULTING THE MOST RECENT JOINT HAZARD CLASSIFICATION SYSTEM LISTING OR OTHER APPROVED LISTING(S).

REVISION

REVISION NO. 1, DATED AUGUST 1994, CONSISTS OF:

1. ADDING ITEM BY NATIONAL STOCK NUMBER TO THE "PALLET UNIT DATA" CHART.
2. CHANGING DODIC AND OD CLASS OF NATIONAL STOCK NUMBERS ON THE "PALLET UNIT DATA" CHART.
3. CHANGING THE DESCRIPTION OF PACKAGING.

GENERAL NOTES

- A. THIS APPENDIX CANNOT STAND ALONE BUT MUST BE USED IN CONJUNCTION WITH THE BASIC UNITIZATION PROCEDURES DRAWING 19-48-4116-20PA1002. TO PRODUCE AN APPROVED UNIT LOAD, ALL PERTINENT PROCEDURES, SPECIFICATIONS AND CRITERIA SET FORTH WITHIN THE BASIC DRAWING WILL APPLY TO THE PROCEDURES DELINEATED IN THIS APPENDIX. ANY EXCEPTIONS TO THE BASIC PROCEDURES ARE SPECIFIED IN THIS APPENDIX.
- B. DIMENSIONS, CUBE AND WEIGHT OF A PALLET UNIT WILL VARY SLIGHTLY DEPENDING UPON THE ACTUAL DIMENSIONS OF THE BOXES AND THE WEIGHT OF THE SPECIFIC ITEM BEING UNITIZED.
- C. INSTALL EACH HORIZONTAL STRAP TO ENCIRCLE A LAYER OF BOXES ON THE PALLET. HORIZONTAL STRAPS MUST BE TENSIONED AND SEALED PRIOR TO THE APPLICATION OF TIEDOWN STRAPS.
- D. INSTALL EACH TIEDOWN STRAP TO PASS UNDER THE TOP DECK BOARDS OF THE PALLET. TIEDOWN STRAPS WILL NOT BE APPLIED UNTIL THE HORIZONTAL STRAPS HAVE BEEN TENSIONED AND SEALED.
- E. THE FOLLOWING AMC DRAWINGS ARE APPLICABLE FOR OUTLOADING AND STORAGE OF THE ITEMS COVERED BY THIS APPENDIX.
 - CARLOADING - - - - 19-48-4115-SPA1002
 - TRUCKLOADING - - - - 19-48-4117-11PA1003
 - STORAGE - - - - 19-48-4118-1-2-3-4-14-22PA1002
 - END OPENING ISO
 - CONTAINER - - - - 19-48-4153-15PA1002
 - MILVAN - - - - 19-48-4166-15PA1003
 - SIDE OPENING ISO
 - CONTAINER - - - - 19-48-4267-15PA1009
- F. FOR METHOD OF SECURING A STRAP CUTTER TO THE PALLET UNIT, SEE AMC DRAWING 19-48-4127-20P1000.
- G. IF ITEMS COVERED HEREIN ARE UNITIZED PRIOR TO ISSUANCE OF THIS APPENDIX, THE BOXES NEED NOT BE REUNITIZED SOLELY TO CONFORM TO THIS APPENDIX.
- H. THE UNITIZATION PROCEDURES DEPICTED HEREIN MAY ALSO BE USED FOR UNITIZING PERCUSSION PRIMERS WHEN IDENTIFIED BY DIFFERENT NATIONAL STOCK NUMBERS (NSN) THAN WHAT IS SHOWN ON PAGE 2, PROVIDED THE BOX PACK DOES NOT VARY FROM WHAT IS DELINEATED HEREIN. THE EXPLOSIVE CLASSIFICATION OF OTHER ITEMS MAY BE DIFFERENT THAN WHAT IS SHOWN.

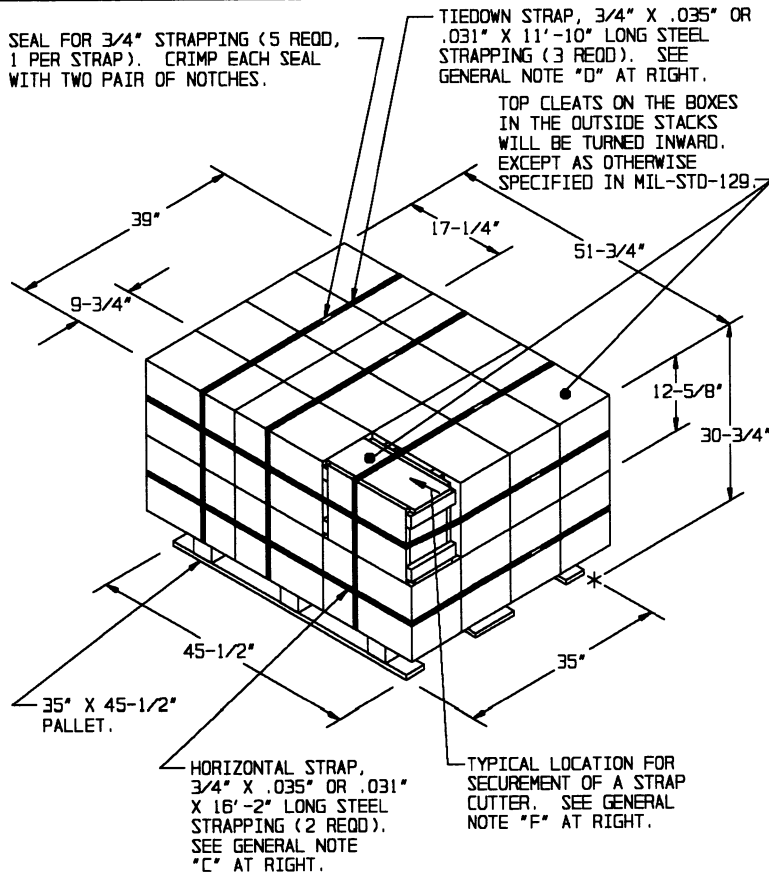

PALLET UNIT

SEE GENERAL NOTE "B" AT RIGHT.

24 BOXES OF PERCUSSION PRIMER (200 PER BOX) AT 86 LBS -	2,064 LBS (APPROX)	J.
DUNNAGE - - - - -	5 LBS	
PALLET - - - - -	65 LBS	
<hr/>		
TOTAL WEIGHT - - - - -	2,134 LBS (APPROX)	
CUBE - - - - -	35.9 CU FT (APPROX)	

THE STYLE 1A PALLET DELINEATED IN THE DETAIL AT LEFT NEED NOT HAVE CHAMFERS OR STRAP SLOTS AS SPECIFIED WITHIN MILITARY SPECIFICATION MIL-P-15011 WHEN USED FOR THE UNITIZATION OF ITEMS COVERED BY THIS APPENDIX.

BILL OF MATERIAL

PALLET, 35" X 45-1/2" - - -	1 REQD - - - - -	65 LBS
STEEL STRAPPING, 3/4" -	67.83' REQD - - - - -	4.85 LBS
SEAL FOR 3/4" STRAPPING - -	5 REQD - - - - -	NIL

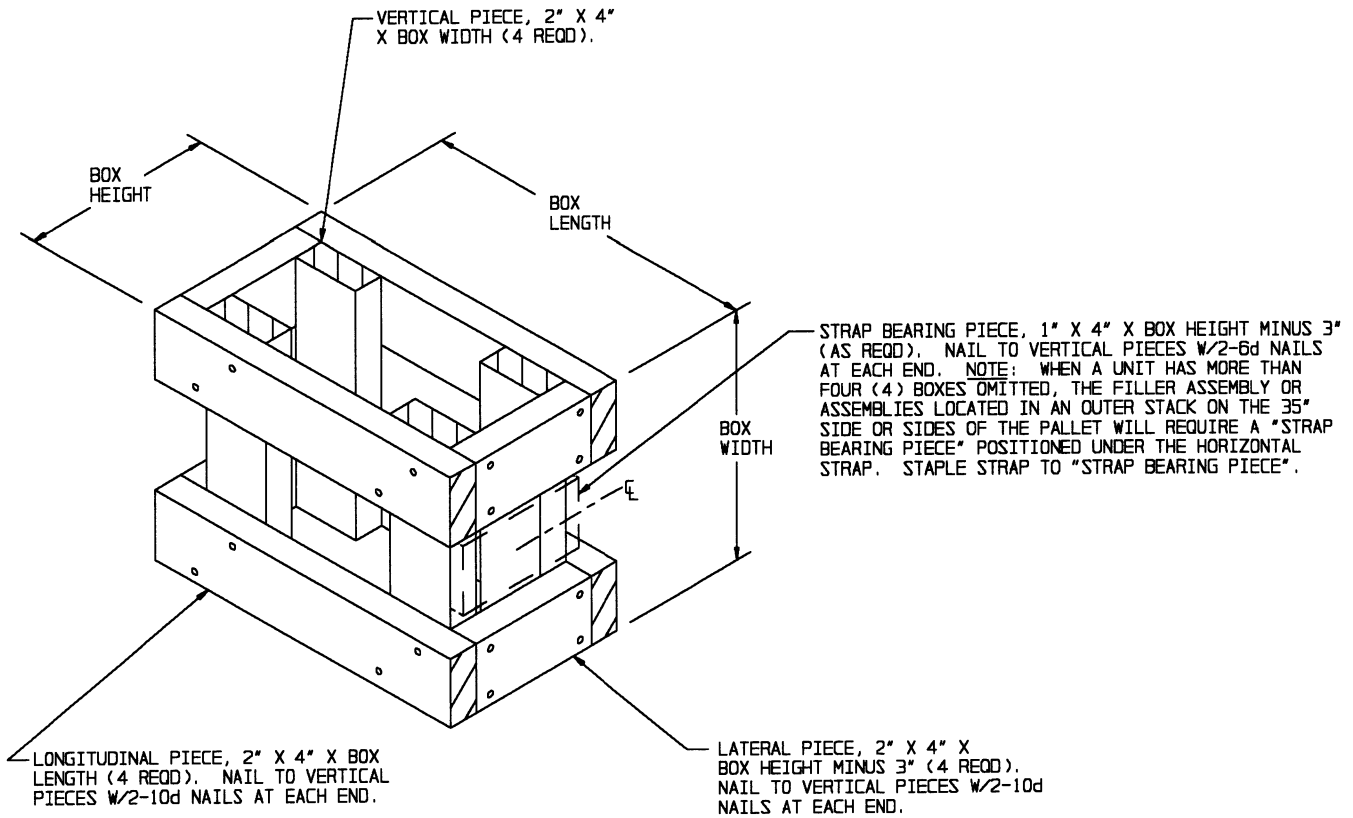

FILLER ASSEMBLY

(FOR MINUS ONE BOX)