

# APPENDIX 151A

## UNITIZATION PROCEDURES FOR BOXED AMMUNITION AND COMPONENTS ON 4-WAY ENTRY PALLETS

CARTRIDGE, IMPULSE, PACKED VARIOUS QUANTITIES  
PER WOODEN BOX, UNITIZED 12 BOXES PER 40" X  
48" PALLET; APPROX BOX SIZE 20 $\frac{1}{8}$ " L X 18 $\frac{5}{8}$ " W  
X 17 $\frac{5}{8}$ " H

PALLET UNIT DATA						
ITEMS INCLUDED		HAZARD CLASSIFICATION ①				WEIGHT (LBS)
NSN	DODIC	DOT CLASS	CG CLASS	QD CLASS	COMP GROUP	
1377- 00-516-9924	M187	C	I	1,4	C	1,034
00-585-9291	M189	C	I	1,4	C	1,214

### REVISIONS

REVISION NO. 1, DATED MARCH 1985, CONSISTS OF:

1. ADDING ITEM BY NATIONAL STOCK NUMBER TO "PALLET UNIT DATA" CHART.
2. UPDATING DRAWING.

**NOTICE:** THIS APPENDIX CANNOT STAND ALONE BUT MUST  
BE USED IN CONJUNCTION WITH THE BASIC UNITIZATION  
PROCEDURES DRAWING 19-48-4116-20PA1002.

① HAZARD CLASSIFICATION DATA CONTAINED IN THE ABOVE CHART IS FOR GUIDANCE AND INFORMATIONAL PURPOSES ONLY. VERIFICATION OF THE SPECIFIED DATA SHOULD BE MADE BY CONSULTING THE MOST RECENT JOINT HAZARD CLASSIFICATION SYSTEM LISTING OR OTHER APPROVED LISTING(S).

**DO NOT SCALE**

REVISIONS				DRAFTSMAN <i>SW</i>	/ <i>LB</i>	PROJ ENG <i>RAR</i>	/ <i>NW</i>
1	MAR 85	<i>WRF</i> <i>wjg</i>	<i>William &amp; Ernst</i>	<i>GBS</i>	<i>W &amp; Ernst</i>		
				APPROVED, U.S. ARMY ARMAMENT, MUNITIONS AND CHEMICAL COMMAND			
				<i>D. Martin</i>		<i>BQ Braden</i>	
				APPROVED BY ORDER OF COMMANDING GENERAL, U. S. ARMY MATERIEL DEVELOPMENT AND READINESS COMMAND (DARCOM)			
				<i>John L. Bryant</i> U. S. ARMY DEFENSE AMMUNITION CENTER AND SCHOOL			
<b>U. S. ARMY DARCOM DRAWING</b>							
<b>APRIL 1984</b>							
		CLASS	DIVISION	DRAWING	FILE		
		19	48	4116/ 151A	20PA 1002		

**GENERAL NOTES**

- A. THIS APPENDIX CANNOT STAND ALONE BUT MUST BE USED IN CONJUNCTION WITH THE BASIC UNITIZATION PROCEDURES DRAWING 19-48-4116-20PA1002. TO PRODUCE AN APPROVED UNIT LOAD, ALL PERTINENT PROCEDURES, SPECIFICATIONS AND CRITERIA SET FORTH WITHIN THE BASIC DRAWING WILL APPLY TO THE PROCEDURES DELINEATED IN THIS APPENDIX. ANY EXCEPTIONS TO THE BASIC PROCEDURES ARE SPECIFIED IN THIS APPENDIX.
- B. DIMENSIONS, CUBE AND WEIGHT OF A PALLET UNIT WILL VARY SLIGHTLY DEPENDING UPON THE ACTUAL DIMENSIONS OF THE BOXES AND THE WEIGHT OF THE SPECIFIC ITEM BEING UNITIZED.
- C. INSTALL EACH TIEDOWN STRAP TO PASS UNDER THE TOP DECK BOARDS OF THE PALLET AND BE LOCATED AS SHOWN. TIEDOWN STRAPS WILL BE APPLIED BUT NOT TENSIONED UNTIL THE LOAD STRAPS HAVE BEEN TENSIONED AND SEALED.
- D. THE LOAD STRAPS MAY BE THREADED THROUGH THE STRAP SLOTS OF THE PALLET OR PREPOSITIONED ON THE PALLET DECK. LOAD STRAPS WILL BE TENSIONED AND SEALED PRIOR TO TIEDOWN STRAPS.
- E. THE FOLLOWING AMC (DARCOM) DRAWINGS ARE APPLICABLE FOR OUT-LOADING AND STORAGE OF THE ITEMS COVERED BY THIS APPENDIX.  
 CARLOADING ---- DRAWING 19-48-4115-5PA1002  
 TRUCKLOADING --- DRAWING 19-48-4117-11PA1003  
 STORAGE ----- DRAWING 19-48-4118-1-2-3-4-14-22PA1002
- F. FOR METHOD OF SECURING A STRAP CUTTER TO THE PALLET UNIT, SEE DARCOM DRAWING 19-48-4127-20P1000.
- G. IF ITEMS COVERED HEREIN ARE UNITIZED PRIOR TO ISSUANCE OF THIS APPENDIX, THE BOXES NEED NOT BE REUNITIZED SOLELY TO CONFORM TO THIS APPENDIX.
- H. THE UNITIZATION PROCEDURES DEPICTED HEREIN MAY ALSO BE USED FOR UNITIZING IMPULSE CARTRIDGES WHEN IDENTIFIED BY DIFFERENT NATIONAL STOCK NUMBERS (NSN) THAN WHAT IS SHOWN ON THE TITLE PAGE, PROVIDED THE BOX PACK DOES NOT VARY FROM WHAT IS DELINEATED HEREIN. THE EXPLOSIVE CLASSIFICATION OF OTHER ITEMS MAY BE DIFFERENT THAN WHAT IS SHOWN.
- J. THE STYLE I PALLET DELINEATED IN THE DETAIL AT LEFT NEED NOT HAVE CHAMFERS OR STRAP SLOTS AS SPECIFIED WITHIN MILITARY SPECIFICATION MIL-P-15011 WHEN USED FOR THE UNITIZATION OF THE ITEMS COVERED BY THIS APPENDIX. IF THE PALLET TO BE USED DOES NOT HAVE STRAP SLOTS, HOWEVER, THE LOAD STRAPS MUST BE PRE-POSITIONED ON THE PALLET DECK PRIOR TO PLACING THE BOXES ON THE PALLET.

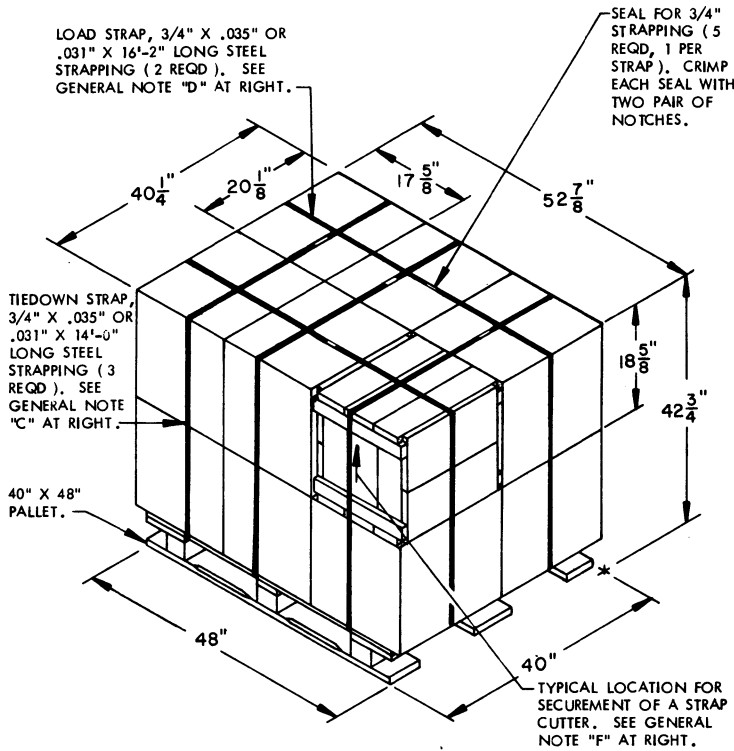

**PALLET UNIT**

SEE GENERAL NOTE "B" AT RIGHT.

12 BOXES OF IMPULSE CARTRIDGES (125 PE. BOX) @ 94 LBS	-----	1,128 LBS (APPROX)
DUNNAGE	-----	6 LBS
PALLET	-----	80 LBS
TOTAL WEIGHT		----- 1,214 LBS (APPROX)
CUBE		----- 52.7 CU FT (APPROX)

**BILL OF MATERIAL**

PALLET, 40" X 48"	----- 1 REQD	----- 80 LBS
STEEL STRAPPING, 3/4"	----- 74.33' REQD	----- 5.31 LBS
SEAL FOR 3/4" STRAPPING	----- 5 REQD	----- NIL

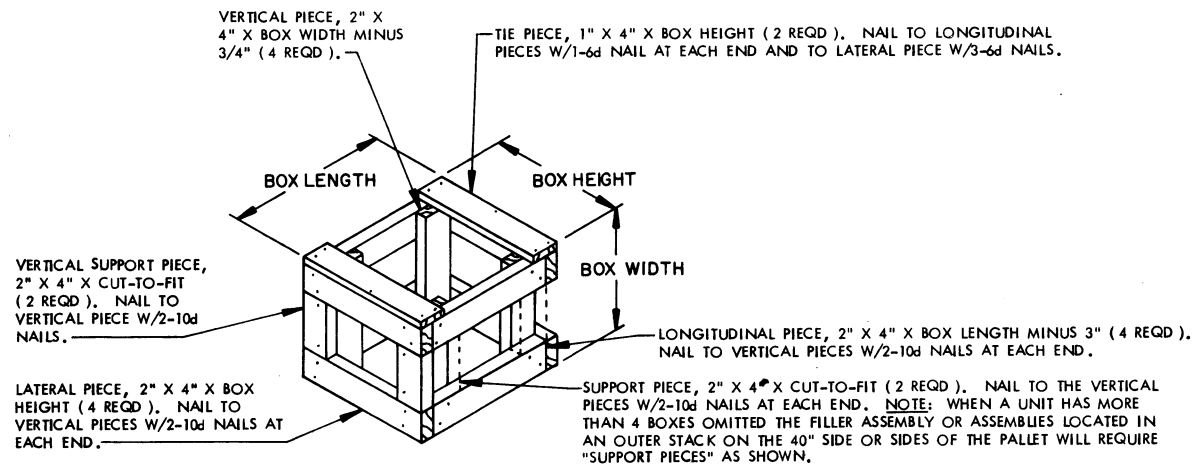

**FILLER ASSEMBLY**  
(FOR MINUS ONE BOX)