

APPENDIX 14L

UNITIZATION PROCEDURES FOR BOXED AMMUNITION AND COMPONENTS ON 4-WAY ENTRY PALLETS

CARTRIDGE, CALIBER .50, PACKED 390 PER
METAL BOX, UNITIZED 30 BOXES PER 35"
X 45 $\frac{1}{2}$ " PALLET; APPROX BOX SIZE 18 $\frac{1}{4}$ " L
X 9 $\frac{1}{2}$ " W X 14 $\frac{3}{4}$ " H

PALLET UNIT DATA						
ITEMS INCLUDED		HAZARD CLASSIFICATION [Ⓢ]				WEIGHT
NSN	DODIC	DOT CLASS	CG CLASS	QD CLASS	COMP GROUP	(LBS)
1305-00-585-5195	A542	C	I	1.4	G	3,853

NOTICE: THIS APPENDIX CANNOT STAND ALONE BUT MUST BE USED IN CONJUNCTION WITH THE BASIC UNITIZATION PROCEDURES DRAWING 19-48-4116-20PA1002.

[Ⓢ] HAZARD CLASSIFICATION DATA CONTAINED IN THE ABOVE CHART IS FOR GUIDANCE AND INFORMATIONAL PURPOSES ONLY. VERIFICATION OF THE SPECIFIED DATA SHOULD BE MADE BY CONSULTING THE MOST RECENT JOINT HAZARD CLASSIFICATION SYSTEM LISTING OR OTHER APPROVED LISTING(S).

DO NOT SCALE

REVISIONS				PROJ. NO.	PROJ. DATE
				19-48-4116-20PA1002	11/83
				CHECKED	LOGGING OFFICER
				<i>RSA</i>	<i>John Sygal</i>
				APPROVED, U. S. ARMY ARMAMENT, IDENTIFICATION AND CHEMICAL DIVISION	
				<i>William J. ...</i>	
				APPROVED BY ORDER OF COMMANDING GENERAL, U. S. ARMY MATERIEL DEVELOPMENT AND READINESS COMMAND (DARCOM)	
				<i>John X. ...</i>	
				U. S. ARMY DARCOC DRAWING	
				NOVEMBER 1983	
				CLASS	DIVISION
				DRAWING	FILE
				19	48
				4116/14L	20PA1002

LOAD STRAP, 3/4" X .035" OR .031" X 16'-5" LONG STEEL STRAPPING (2 REQD). SEE GENERAL NOTE "C" AT RIGHT.

SEAL FOR 3/4" STRAPPING (7 REQD, 1 PER STRAP). CRIMP EACH SEAL WITH TWO PAIR OF NOTCHES.

TIEDOWN STRAP, 3/4" X .035" OR .031" X 14'-7" LONG STEEL STRAPPING (5 REQD). SEE GENERAL NOTE "D" AT RIGHT.

35" X 45-1/2" PALLET.

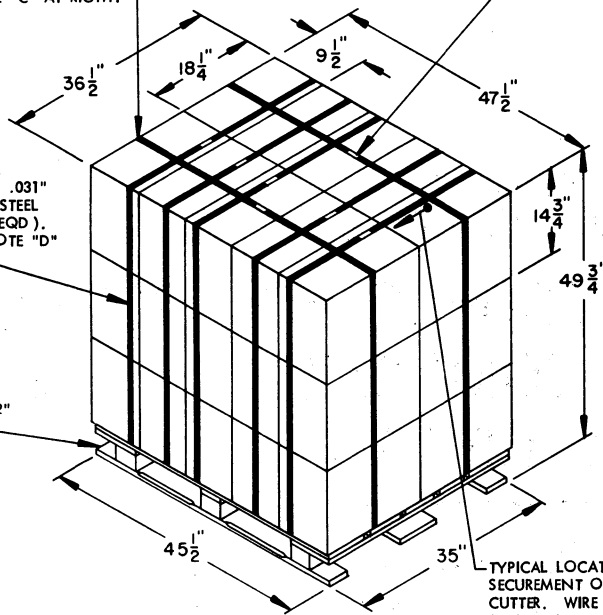

TYPICAL LOCATION FOR SECUREMENT OF A STRAP CUTTER. WIRE TIE TO STRAP. SEE GENERAL NOTE "F" AT RIGHT.

PALLET UNIT

SEE GENERAL NOTE "B" AT RIGHT.

30 BOXES OF .50 CALIBER CARTRIDGE (390 PER BOX) @ 126 LBS -----	3,780 LBS (APPROX)
DUNNAGE-----	8 LBS
PALLET-----	65 LBS
TOTAL WEIGHT -----	3,853 LBS (APPROX)
CUBE -----	49.9 CU FT (APPROX)

BILL OF MATERIAL

PALLET, 35" X 45-1/2"-----	1 REQD-----	65 LBS
STEEL STRAPPING, 3/4"-----	105.75 REQD-----	7.55 LBS
SEAL FOR 3/4" STRAPPING-----	7 REQD-----	NIL

GENERAL NOTES

- A. THIS APPENDIX CANNOT STAND ALONE BUT MUST BE USED IN CONJUNCTION WITH THE BASIC UNITIZATION PROCEDURES DRAWING 19-48-4116-20PA1002. TO PRODUCE AN APPROVED UNIT LOAD, ALL PERTINENT PROCEDURES, SPECIFICATIONS AND CRITERIA SET FORTH WITHIN THE BASIC DRAWING WILL APPLY TO THE PROCEDURES DELINEATED IN THIS APPENDIX. ANY EXCEPTIONS TO THE BASIC PROCEDURES ARE SPECIFIED IN THIS APPENDIX.
- B. DIMENSIONS, CUBE AND WEIGHT OF A PALLET UNIT WILL VARY SLIGHTLY DEPENDING UPON THE ACTUAL DIMENSIONS OF THE BOXES AND THE WEIGHT OF THE SPECIFIC ITEM BEING UNITIZED.
- C. THE LOAD STRAPS WILL BE THREADED THROUGH THE STRAP SLOTS OF A PALLET. LOAD STRAPS MUST BE TENSIONED AND SEALED PRIOR TO APPLICATION OF TIEDOWN STRAPS.
- D. INSTALL EACH TIEDOWN STRAP TO PASS UNDER THE TOP DECK BOARDS OF THE PALLET AND TO BE LOCATED AS SHOWN. TIEDOWN STRAPS WILL NOT BE APPLIED UNTIL THE LOAD STRAPS HAVE BEEN TENSIONED AND SEALED.
- E. THE FOLLOWING DARCOM DRAWINGS ARE APPLICABLE FOR OUTLOADING AND STORAGE OF THE ITEMS COVERED BY THIS APPENDIX.
 - CARLOADING----- DRAWING 19-48-4115-5PA1002
 - TRUCKLOADING -- DRAWING 19-48-4117-11PA1003
 - STORAGE----- DRAWING 19-48-4118-1-2-3-4-14-22PA1002
- F. FOR METHOD OF SECURING A STRAP CUTTER TO THE PALLET UNIT, SEE DARCOM DRAWING 19-48-4127-20P1000
- G. IF ITEMS COVERED HEREIN ARE UNITIZED PRIOR TO ISSUANCE OF THIS APPENDIX, THE BOXES NEED NOT BE REUNITIZED SOLELY TO CONFORM TO THIS APPENDIX.
- H. THE UNITIZATION PROCEDURES DEPICTED HEREIN MAY ALSO BE USED FOR UNITIZING .50 CALIBER CARTRIDGES WHEN IDENTIFIED BY DIFFERENT NATIONAL STOCK NUMBERS (NSN) THAN WHAT IS SHOWN ON THE TITLE PAGE, PROVIDED THE BOX PACK DOES NOT VARY FROM WHAT IS DELINEATED HEREIN. THE EXPLOSIVE CLASSIFICATION OF OTHER ITEMS MAY BE DIFFERENT THAN WHAT IS SHOWN.
- J. WHEN THE UNIT LOAD DEPICTED AT LEFT IS TO BE USED FOR UNITIZING MARINE CORPS AMMUNITION, ONE LAYER OF BOXES MUST BE OMITTED, TIEDOWN STRAP LENGTHS MUST BE DECREASED TO 12'-1", AND LOAD STRAP LENGTHS MUST BE DECREASED TO 13'-11". THIS WILL RESULT IN AN OVERALL UNIT HEIGHT OF 35", A GROSS UNIT WEIGHT OF 2,088 POUNDS, AND A UNIT CUBE OF 35.1 CUBIC FEET. ADDITIONALLY, THE UNIT LOAD MAY BE MODIFIED AS DESCRIBED WHEN BEING SHIPPED BY MILVAN OR COMMERCIAL INTERMODAL FREIGHT CONTAINER, CONVENTIONAL VAN TRAILER OR CONVENTIONAL OR HIGH-CAPACITY BOXCAR. THE DETERMINATION TO REDUCE THE LOAD BY A LAYER FOR TRANSPORTATION WILL BE MADE BY THE RESPONSIBLE COMMAND AND WILL BE BASED UPON ECONOMICS OF TRANSPORTATION AND HANDLING.

VERTICAL PIECE, 2" X 4" X BOX HEIGHT MINUS 3/4" (4 REQD).

TIE PIECE, 1" X 4" X BOX WIDTH (2 REQD). NAIL TO LONGITUDINAL PIECES W/2-6d NAILS AT EACH END AND NAIL TO LATERAL PIECE W/1-6d NAIL.

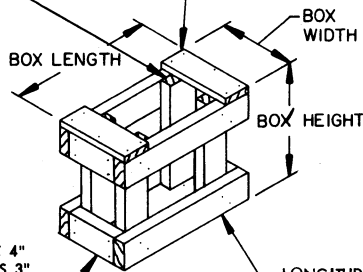

LATERAL PIECE, 2" X 4" X BOX WIDTH MINUS 3" (4 REQD). NAIL TO VERTICAL PIECES W/2-10d NAILS AT EACH END.

LONGITUDINAL PIECE, 2" X 4" X BOX LENGTH (4 REQD). NAIL TO VERTICAL PIECES W/2-10d NAILS AT EACH END.

FILLER ASSEMBLY
(FOR MINUS ONE BOX.)