

APPENDIX 14G

UNITIZATION PROCEDURES FOR BOXED AMMUNITION AND COMPONENTS ON 4-WAY ENTRY PALLETS

CARTRIDGE, CALIBER .50, PACKED 210 PER
WOODEN BOX, UNITIZED 24 BOXES PER 35" X
45 $\frac{1}{2}$ " PALLET; APPROX BOX SIZE 15 $\frac{3}{8}$ " L X
9 $\frac{1}{2}$ " W X 14 $\frac{7}{8}$ " H

PALLET UNIT DATA						
ITEMS INCLUDED		HAZARD CLASSIFICATION				WEIGHT (LBS)
NSN	DODIC	DOT CLASS	CG CLASS	QD CLASS	COMP GROUP	
1305- 00-028-6453	A534	C	I	1.4	G	2,110

NOTICE: THIS APPENDIX CANNOT STAND ALONE BUT MUST
BE USED IN CONJUNCTION WITH THE BASIC UNITIZATION
PROCEDURES DRAWING 19-48-4116-20PA1002.

REVISIONS				DRAFTSMAN J.M.H. / MJK	PROJ ENG S.F. / 1234
				CHECKER S.M.	LOG ENGRG OFFICE S.M.
				APPROVED, U. S. ARMY ARMAMENT MATERIEL READINESS COMMAND	
				<i>Lawrence Kuester</i> / <i>David C. Feltz</i> DRBAR-MAD / DRBAR-TUD	
				APPROVED BY ORDER OF COMMANDING GENERAL, U. S. ARMY MATERIEL DEVELOPMENT AND READINESS COMMAND (DARCOM)	
				<i>John L. Reynolds</i> U. S. ARMY DEFENSE AMMUNITION CENTER AND SCHOOL	
				U. S. ARMY DARCOM DRAWING	
				APRIL 1980	
		CLASS	DIVISION	DRAWING	FILE
		19	48	4116/14G	20PA 1002

DO NOT SCALE

GENERAL NOTES

- A. THIS APPENDIX CANNOT STAND ALONE BUT MUST BE USED IN CONJUNCTION WITH THE BASIC UNITIZATION PROCEDURES DRAWING 19-48-4116-20PA1002. TO PRODUCE AN APPROVED UNIT LOAD, ALL PERTINENT PROCEDURES, SPECIFICATIONS AND CRITERIA SET FORTH WITHIN THE BASIC DRAWING WILL APPLY TO THE PROCEDURES DELINEATED IN THIS APPENDIX. ANY EXCEPTIONS TO THE BASIC PROCEDURES ARE SPECIFIED IN THIS APPENDIX.
- B. DIMENSIONS, CUBE AND WEIGHT OF A PALLET UNIT WILL VARY SLIGHTLY DEPENDING UPON THE ACTUAL DIMENSIONS OF THE BOXES AND THE WEIGHT OF THE SPECIFIC ITEM BEING UNITIZED.
- C. INSTALL EACH HORIZONTAL STRAP TO ENCIRCLE A LAYER OF BOXES ON THE PALLET. HORIZONTAL STRAPS MUST BE TENSIONED AND SEALED PRIOR TO APPLICATION OF TIEDOWN STRAPS.
- D. INSTALL EACH TIEDOWN STRAP TO PASS UNDER THE TOP DECK BOARDS OF THE PALLET AND TO BE LOCATED AS SHOWN. TIEDOWN STRAPS WILL NOT BE APPLIED UNTIL THE HORIZONTAL STRAPS HAVE BEEN TENSIONED AND SEALED.
- E. THE FOLLOWING DARCOM DRAWINGS ARE APPLICABLE FOR OUT-LOADING AND STORAGE OF THE ITEMS COVERED BY THIS APPENDIX.
 - CARLOADING ----- DRAWING 19-48-4115-5PA1002
 - TRUCKLOADING ----- DRAWING 19-48-4117-11PA1003
 - STORAGE ----- DRAWING 19-48-4118-1-2-14-22PA1002
- F. FOR METHOD OF SECURING A STRAP CUTTER TO THE PALLET UNIT, SEE DARCOM DRAWING 19-48-4127-20P1000.
- G. IF ITEMS COVERED HEREIN ARE UNITIZED PRIOR TO ISSUANCE OF THIS APPENDIX, THE BOXES NEED NOT BE REUNITIZED SOLELY TO CONFORM TO THIS APPENDIX.
- H. THE UNITIZATION PROCEDURES DEPICTED HEREIN MAY ALSO BE USED FOR UNITIZING .50 CALIBER CARTRIDGES WHEN IDENTIFIED BY DIFFERENT NATIONAL STOCK NUMBERS (NSN) THAN WHAT IS SHOWN ON THE TITLE PAGE, PROVIDED THE BOX PACK DOES NOT VARY FROM WHAT IS DELINEATED HEREIN. THE EXPLOSIVE CLASSIFICATION OF OTHER ITEMS MAY BE DIFFERENT THAN WHAT IS SHOWN.

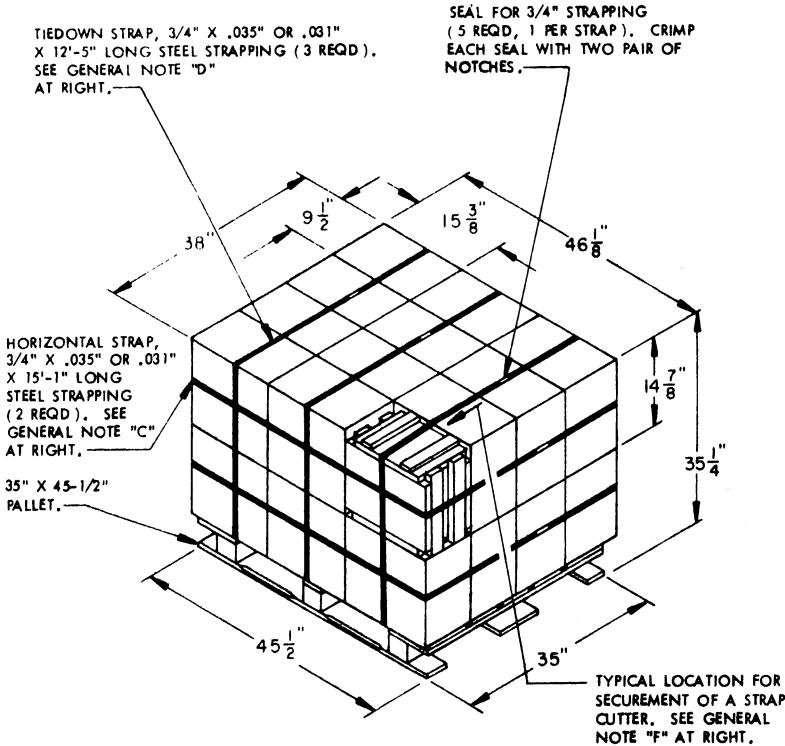

PALLET UNIT

SEE GENERAL NOTE "B" AT RIGHT.

24 BOXES OF .50 CALIBER CARTRIDGES (210 PER BOX) @ 85 LBS --- 2,040 LBS (APPROX)
 DUNNAGE ----- 5 LBS
 PALLET ----- 65 LBS

TOTAL WEIGHT ----- 2,110 LBS (APPROX)
 CUBE ----- 35.8 CU FT (APPROX)

BILL OF MATERIAL

PALLET, 35" X 45-1/2"	1 REQD	65 LBS
STEEL STRAPPING, 3/4"	67.42' REQD	4.82 LBS
SEAL FOR 3/4" STRAPPING	5 REQD	NIL

TIE PIECE, 1" X 4" X BOX WIDTH (2 REQD).
 NAIL TO LONGITUDINAL PIECES W/2-6d NAILS
 AT EACH END AND TO LATERAL PIECE W/1-6d
 NAIL.

VERTICAL PIECE,
 2" X 4" X BOX
 HEIGHT MINUS
 3/4" (4 REQD).

LONGITUDINAL PIECE,
 2" X 4" X BOX LENGTH
 (4 REQD). NAIL TO
 VERTICAL PIECES W/2-10d
 NAILS AT EACH END.

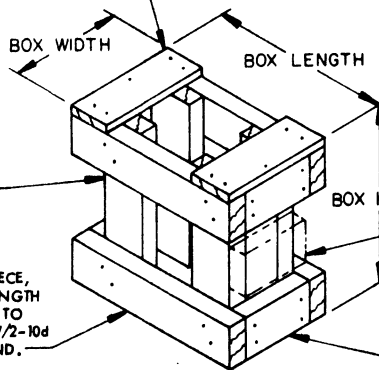

STRAP BEARING PIECE, 2" X 4" X BOX WIDTH MINUS 3" (AS REQD).
 NAIL TO VERTICAL PIECES W/2-10d NAILS AT EACH END. NOTE:
 WHEN A UNIT HAS MORE THAN FOUR (4) BOXES OMITTED, THE
 FILLER ASSEMBLY OR ASSEMBLIES LOCATED IN AN OUTER STACK ON
 THE 35" SIDE OR SIDES OF THE PALLET WILL REQUIRE A "STRAP
 BEARING PIECE" POSITIONED UNDER THE HORIZONTAL STRAP.
 STAPLE STRAP TO THE "STRAP BEARING PIECE".

LATERAL PIECE, 2" X 4" X BOX WIDTH MINUS 3"
 (4 REQD). NAIL TO VERTICAL PIECES W/2-10d
 NAILS AT EACH END.

FILLER ASSEMBLY

(FOR MINUS ONE BOX)