

# APPENDIX 149

## UNITIZATION PROCEDURES FOR BOXED AMMUNITION AND COMPONENTS ON 4-WAY ENTRY PALLETS

FASTENER UNIT, POWDER ACTUATED TOOL, W/CTG,  
CALIBER .38 AND DISK, PACKED 300 UNITS AND  
1500 DISKS PER WIREBOUND BOX, UNITIZED  
12 BOXES PER 35" X 45½" PALLET; APPROX BOX  
SIZE 21¾" L X 18½" W X 11½" H

PALLET UNIT DATA						
ITEMS INCLUDED		HAZARD CLASSIFICATION				WEIGHT ( LBS )
'NSN	DODIC	DOT CLASS	CG CLASS	QD CLASS	COMP GROUP	
1377-00- 344-2369	M155	C	I	1	BEN	2,088

**NOTICE:** THIS APPENDIX CANNOT STAND ALONE BUT MUST  
BE USED IN CONJUNCTION WITH THE BASIC UNITIZATION  
PROCEDURES DRAWING 19-48-4116-20PA1002.

REVISIONS				DRAFTSMAN <i>S.M.H. / msk</i>	PROJ ENG <i>GBF / News</i>
				CHECKER <i>RSK / BJB</i>	LOG ENG'G OFFICE <i>John Bond</i>
APPROVED, U. S. ARMY ARMAMENT MATERIEL READINESS COMMAND					
				<i>J.A. Jackson</i> DDBAR-MAD	<i>David L. Fetter</i> DDBAR-TBA
APPROVED BY ORDER OF COMMANDING GENERAL, U. S. ARMY MATERIEL DEVELOPMENT AND READINESS COMMAND (DARCOM)					
<i>W. S. Ehinger</i> DARCOM AMMO CENTER					
U. S. ARMY DARCOM DRAWING					
OCTOBER 1977					
CLASS	DIVISION	DRAWING	FILE		
19	48	4116/149	20PA 1002		

**DO NOT SCALE**

**GENERAL NOTES**

- A. THIS APPENDIX CANNOT STAND ALONE BUT MUST BE USED IN CONJUNCTION WITH THE BASIC UNITIZATION PROCEDURES DRAWING 19-48-4116-20PA1002. TO PRODUCE AN APPROVED UNIT LOAD, ALL PERTINENT PROCEDURES, SPECIFICATIONS AND CRITERIA SET FORTH WITHIN THE BASIC DRAWING WILL APPLY TO THE PROCEDURES DELINEATED IN THIS APPENDIX. ANY EXCEPTIONS TO THE BASIC PROCEDURES ARE SPECIFIED IN THIS APPENDIX.
- B. DIMENSIONS, CUBE AND WEIGHT OF A PALLET UNIT WILL VARY SLIGHTLY DEPENDING UPON THE ACTUAL DIMENSIONS OF THE BOXES AND THE WEIGHT OF THE SPECIFIC ITEM BEING UNITIZED.
- C. INSTALL EACH HORIZONTAL STRAP TO ENIRCLE EACH LAYER OF BOXES ON THE PALLET. NOTE THAT THE STRAPS WILL BE LOCATED AS DIMENSIONED, NEAR THE TOP OF EACH LAYER. HORIZONTAL STRAPS MUST BE TENSIONED AND SEALED PRIOR TO APPLICATION OF TIEDOWN STRAPS.
- D. INSTALL EACH TIEDOWN STRAP TO PASS UNDER THE TOP DECK BOARDS OF THE PALLET AND TO BE LOCATED AS SHOWN. TIEDOWN STRAPS WILL NOT BE APPLIED UNTIL THE LOAD STRAPS HAVE BEEN TENSIONED AND SEALED.
- E. THE FOLLOWING DARCOM DRAWINGS ARE APPLICABLE FOR OUTLOADING AND STORAGE OF THE ITEMS COVERED BY THIS APPENDIX.
  - CARLOADING ----- DRAWING 19-48-4115-5PA1002
  - TRUCKLOADING ----- DRAWING 19-48-4117-11PA1003
  - STORAGE ----- DRAWING 19-48-4118-1-2-14-22PA1002
- F. FOR METHOD OF SECURING A STRAP CUTTER TO THE PALLET UNIT, SEE DARCOM DRAWING 19-48-4127-20P1000.
- G. IF ITEMS COVERED HEREIN ARE UNITIZED PRIOR TO ISSUANCE OF THIS APPENDIX, THE BOXES NEED NOT BE REUNITIZED SOLELY TO CONFORM TO THIS APPENDIX.
- H. THE UNITIZATION PROCEDURES DEPICTED HEREIN MAY ALSO BE USED FOR UNITIZING FASTENER UNITS WHEN IDENTIFIED BY DIFFERENT NATIONAL STOCK NUMBERS (NSN) THAN WHAT IS SHOWN ON THE TITLE PAGE, PROVIDED THE BOX PACK DOES NOT VARY FROM WHAT IS DELINEATED HEREIN. THE EXPLOSIVE CLASSIFICATION OF OTHER ITEMS MAY BE DIFFERENT THAN WHAT IS SHOWN.
- J. POSITION THE TWO OUTBOARD BOXES ON EACH END OF THE BOTTOM LAYER OF THE UNIT WITH THE TOP DOWNWARD, AND THE TWO OUTBOARD BOXES ON EACH END OF THE TOP LAYER OF THE UNIT WITH THE TOP UPWARD.

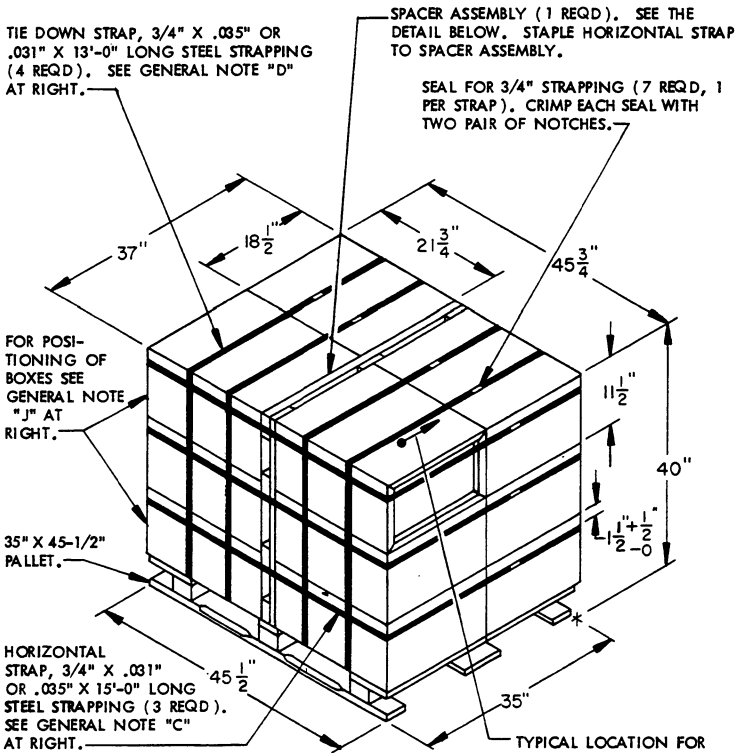

**PALLET UNIT**

SEE GENERAL NOTE "B" AT RIGHT.

12 BOXES OF FASTENER UNITS (300 PER BOX) @ 166 LBS	-----	1,922 LBS (APPROX)
DUNNAGE	-----	31 LBS
PALLET	-----	65 LBS
<b>TOTAL WEIGHT</b>	-----	<b>2,088 LBS (APPROX)</b>
<b>CUBE</b>	-----	<b>39.8 CU FT (APPROX)</b>

**BILL OF MATERIAL**

LUMBER	LINEAR FEET	BOARD FEET
1" X 4"	9	3
2" X 4"	13	9
NAILS	NO. REQD	POUNDS
6d (3")	24	NIL
PALLET, 35" X 45-1/2"	1 REQD	65 LBS
STEEL STRAPPING, 3/4"	97' REQD	7 LBS
SEAL FOR 3/4" STRAPPING	7 REQD	NIL

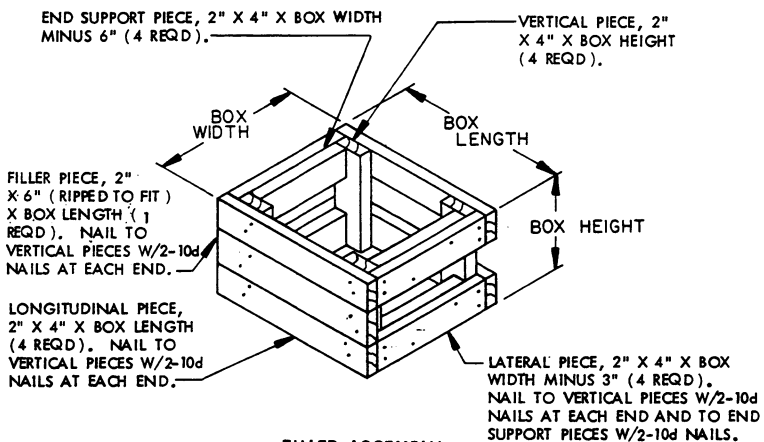

**FILLER ASSEMBLY**

(FOR MINUS ONE BOX)

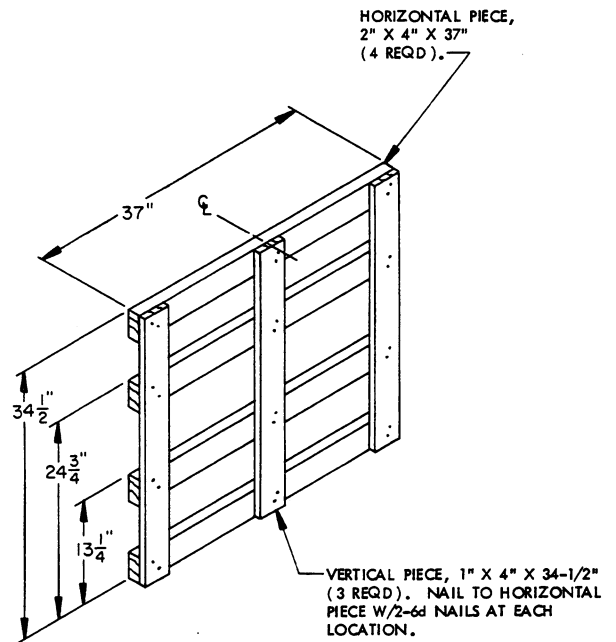

**SPACER ASSEMBLY**

(1 REQD)