

# APPENDIX 147

## UNITIZATION PROCEDURES FOR BOXED AMMUNITION AND COMPONENTS ON 4-WAY ENTRY PALLETS

CUTTER, CABLE, PACKED 48 PER WOODEN BOX,  
UNITIZED 4 BOXES PER 35" X 45½" PALLET; APPROX  
BOX SIZE 34<sup>7</sup>/<sub>8</sub>" L X 24<sup>1</sup>/<sub>8</sub>" W X 18<sup>3</sup>/<sub>8</sub>" H

PALLET UNIT DATA						
ITEMS INCLUDED		HAZARD CLASSIFICATION				WEIGHT (LBS)
NSN	DOD IC	DOT CLASS	CG CLASS	QD CLASS	COMP GROUP	
1375- 00-653-9754	M485	A	IX-B	1.1	D	716

### REVISION

REVISION NO. 1, DATED OCTOBER 1988, CONSISTS OF:

1. CHANGING BOX WEIGHT.
2. ADDING GENERAL NOTE "K".

NOTICE: THIS APPENDIX CANNOT STAND ALONE BUT MUST  
BE USED IN CONJUNCTION WITH THE BASIC UNITIZATION  
PROCEDURES DRAWING 19-48-4116-20PA1002.

**DO NOT SCALE**

REVISIONS		DRAFTSMAN	PLOT	FILED	NLN(10)
1	OCT 88	<i>WRE</i>	<i>WRE</i>	<i>WRE</i>	<i>WRE</i>
		<small>APPROVED, U. S. ARMY ARMAMENT MATERIEL READINESS COMMAND</small> <small>DARCOM - LEP</small>			
		<small>APPROVED BY ORDER OF COMMANDING GENERAL, U. S. ARMY</small> <small>MATERIEL DEVELOPMENT AND READINESS COMMAND (DARCOM)</small> <small>U. S. ARMY DEFENSE AMMUNITION CENTER AND SCHOOL</small>			
<b>U. S. ARMY DARCOM DRAWING</b>					
<b>JUNE 1981</b>					
CLASS	DIVISION	DRAWING	FILE		
19	48	4116/ 147	20PA 1002		

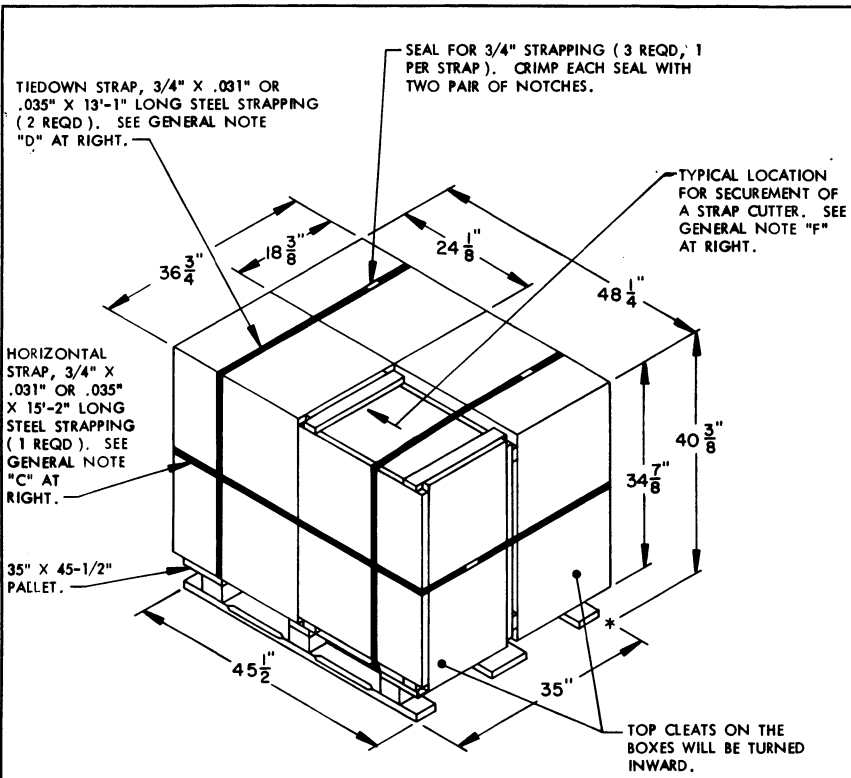

**GENERAL NOTES**

- A. THIS APPENDIX CANNOT STAND ALONE BUT MUST BE USED IN CONJUNCTION WITH THE BASIC UNITIZATION PROCEDURES DRAWING 19-48-4116-20PA1002. TO PRODUCE AN APPROVED UNIT LOAD, ALL PERTINENT PROCEDURES, SPECIFICATIONS AND CRITERIA SET FORTH WITHIN THE BASIC DRAWING WILL APPLY TO THE PROCEDURES DELINEATED IN THIS APPENDIX. ANY EXCEPTIONS TO THE BASIC PROCEDURES ARE SPECIFIED IN THIS APPENDIX.
- B. DIMENSIONS, CUBE AND WEIGHT OF A PALLET UNIT WILL VARY SLIGHTLY DEPENDING UPON THE ACTUAL DIMENSIONS OF THE BOXES AND THE WEIGHT OF THE SPECIFIC ITEM BEING UNITIZED.
- C. INSTALL THE HORIZONTAL STRAP TO ENIRCLE THE LAYER OF BOXES ON THE PALLET. HORIZONTAL STRAP MUST BE TENSIONED AND SEALED PRIOR TO APPLICATION OF TIEDOWN STRAPS.
- D. INSTALL EACH TIEDOWN STRAP TO PASS UNDER THE TOP DECK BOARDS OF THE PALLET AND TO BE LOCATED AS SHOWN. TIEDOWN STRAPS WILL NOT BE APPLIED UNTIL THE HORIZONTAL STRAP HAS BEEN TENSIONED AND SEALED.
- E. THE FOLLOWING DARCOM DRAWINGS ARE APPLICABLE FOR OUTLOADING AND STORAGE OF THE ITEMS COVERED BY THIS APPENDIX.
  - CARLOADING ----- DWG 19-48-4115-5PA1002.
  - TRUCKLOADING ----- DWG 19-48-4117-11PA1003.
  - STORAGE ----- DWG 19-48-4118-1-2-3-4-14-22PA1002.
- F. FOR METHOD OF SECURING A STRAP CUTTER TO THE PALLET UNIT, SEE DARCOM DRAWING 19-48-4127-80P1000.
- G. IF ITEMS COVERED HEREIN ARE UNITIZED PRIOR TO ISSUANCE OF THIS APPENDIX, THE BOXES NEED NOT BE REUNITIZED SOLELY TO CONFORM TO THIS APPENDIX.
- H. THE UNITIZATION PROCEDURES DEPICTED HEREIN MAY ALSO BE USED FOR UNITIZING CUTTER, CABLE WHEN IDENTIFIED BY DIFFERENT NATIONAL STOCK NUMBERS (NSN) THAN WHAT IS SHOWN ON THE TITLE PAGE, PROVIDED THE BOX PACK DOES NOT VARY FROM WHAT IS DELINEATED HEREIN. THE EXPLOSIVE CLASSIFICATION OF OTHER ITEMS MAY BE DIFFERENT THAN WHAT IS SHOWN.
- J. IF THERE IS A NEED TO USE FILLER ASSEMBLIES AND AT LEAST TWO PALLET UNITS ARE BEING CONSTRUCTED, NOT MORE THAN TWO FILLERS WILL BE INSTALLED IN ANY ONE PALLET UNIT. USING TWO PALLET UNITS TO SATISFY THE PALLETIZATION CRITERIA APPLICABLE TO LESS-THAN-FULL PALLET UNITS IS AN EXCEPTION TO THE BASIC PROCEDURES. HOWEVER, THE EXCEPTION IS NECESSARY FOR THE AMMUNITION PACK COVERED BY THIS APPENDIX TO MOST EFFECTIVELY GET AN ACCEPTABLE, COMPACT AND SOUND PALLET UNIT.
- K. THE STYLE 1A PALLET DELINEATED IN THE DETAIL AT LEFT NEED NOT HAVE CHAMFERS OR STRAP SLOTS AS SPECIFIED WITHIN MILITARY SPECIFICATION MIL-P-15011 WHEN USED FOR THE UNITIZATION OF THE ITEMS COVERED BY THIS APPENDIX.

**PALLET UNIT**

SEE GENERAL NOTE "B" AT RIGHT.

4 BOXES OF CUTTERS (48 PER BOX) @ 162 LBS ----- 648 LBS (APPROX)  
 DUNNAGE ----- 3 LBS  
 PALLET ----- 65 LBS

TOTAL WEIGHT ----- 716 LBS (APPROX)  
 CUBE ----- 41.4 CU FT (APPROX)

**BILL OF MATERIAL**

PALLET, 35" X 45-1/2"	1 REQD	65 LBS
STEEL STRAPPING, 3/4"	41.33 REQD	2.95 LBS
SEAL FOR 3/4" STRAPPING	8 REQD	NIL

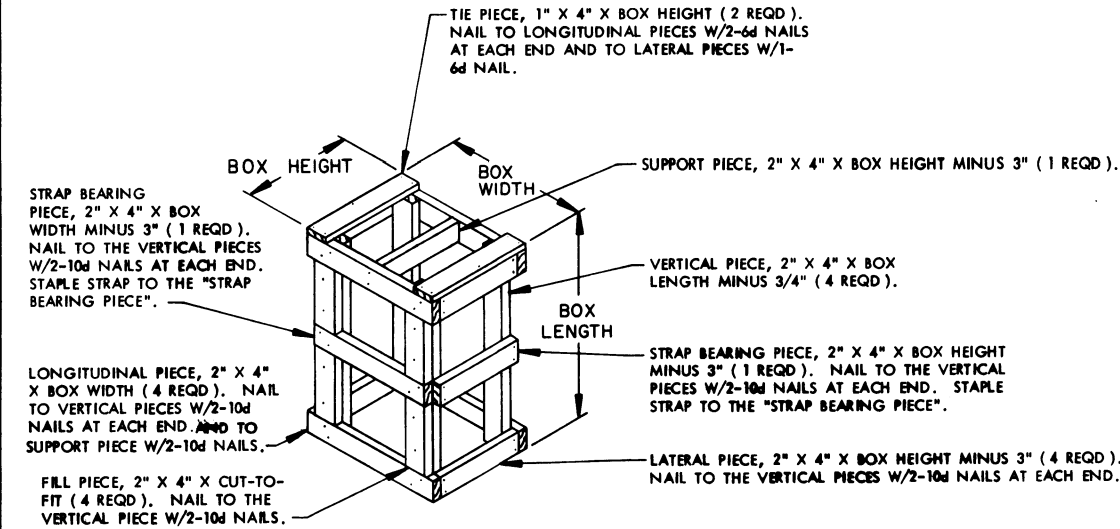

**FILLER ASSEMBLY**

(FOR MINUS ONE BOX)