

APPENDIX 146C

UNITIZATION PROCEDURES FOR BOXED AMMUNITION AND COMPONENTS ON 4 - WAY ENTRY PALLETS

CUTTER, CARTRIDGE ACTUATED, PACKED 10 PER
M19 SERIES METAL CAN, 4 CANS PER WIREBOUND
BOX, UNITIZED 16 BOXES PER 35" X 45½" PALLET;
APPROX BOX SIZE 17⅜" L X 11½" W X 8⅛" H

PALLET UNIT DATA						
ITEMS INCLUDED		HAZARD CLASSIFICATION ①				WEIGHT
NSN	DODIC	DOT CLASS	CG CLASS	QD CLASS	COMP GROUP	(LBS)
1377 00-306-7922	M500	C	I	1.4	S	630

NOTICE: THIS APPENDIX CANNOT STAND ALONE BUT MUST BE USED IN CONJUNCTION WITH THE BASIC UNITIZATION PROCEDURES DRAWING 19-48-4116-20PA1002.

① HAZARD CLASSIFICATION DATA CONTAINED IN THE ABOVE CHART IS FOR GUIDANCE AND INFORMATIONAL PURPOSES ONLY. VERIFICATION OF THE SPECIFIED DATA SHOULD BE MADE BY CONSULTING THE MOST RECENT JOINT HAZARD CLASSIFICATION SYSTEM LISTING OR OTHER APPROVED LISTING(S).

REVISIONS				DRAFTSMAN <i>Dier</i>	PROJ ENG <i>M. WRF</i>
				CHECKER <i>GBE</i>	LDD ENGINEER OFFICE <i>LA GAW</i>
				APPROVED, U.S. ARMY ARMAMENT, MUNITIONS AND CHEMICAL COMMAND	
				<i>W. Benton</i>	<i>B. J. Johnson</i>
				APPROVED BY ORDER OF COMMANDING GENERAL, U.S. ARMY MATERIAL COMMAND (AMC)	
				<i>John F. Reynolds</i> U.S. ARMY DEFENSE AMMUNITION CENTER AND SCHOOL	
U.S. ARMY AMC DRAWING					
JANUARY 1985					
				CLASS	DIVISION
				DRAWING	FILE
				19	48
				4116/ 146C	20PA 1002

DO NOT SCALE

GENERAL NOTES

- A. THIS APPENDIX CANNOT STAND ALONE BUT MUST BE USED IN CONJUNCTION WITH THE BASIC UNITIZATION PROCEDURES DRAWING 19-48-4116-20PA1002. TO PRODUCE AN APPROVED UNIT LOAD, ALL PERTINENT PROCEDURES, SPECIFICATIONS AND CRITERIA SET FORTH WITHIN THE BASIC DRAWING WILL APPLY TO THE PROCEDURES DELINEATED IN THIS APPENDIX. ANY EXCEPTIONS TO THE BASIC PROCEDURES ARE SPECIFIED IN THIS APPENDIX.
- B. DIMENSIONS, CUBE AND WEIGHT OF A PALLET UNIT WILL VARY SLIGHTLY DEPENDING UPON THE ACTUAL DIMENSIONS OF THE BOXES AND THE WEIGHT OF THE SPECIFIC ITEM BEING UNITIZED.
- C. THE LOAD STRAPS MAY BE THREADED THROUGH THE STRAP SLOTS OF THE PALLET OR PREPOSITIONED ON THE PALLET DECK PRIOR TO PLACING BOXES ON THE PALLET. LOAD STRAPS MUST BE TENSIONED AND SEALED PRIOR TO APPLICATION OF TIEDOWN STRAPS.
- D. INSTALL EACH TIEDOWN STRAP TO PASS UNDER THE TOP DECK BOARDS OF THE PALLET AND TO BE LOCATED AS SHOWN. TIEDOWN STRAPS WILL NOT BE APPLIED UNTIL THE LOAD STRAPS HAVE BEEN TENSIONED AND SEALED.
- E. THE FOLLOWING AMC (DARCOM) DRAWINGS ARE APPLICABLE FOR OUTLOADING AND STORAGE OF THE ITEMS COVERED BY THIS APPENDIX.
 CARLOADING----DRAWING 19-48-4115-5PA1002
 TRUCKLOADING -DRAWING 19-48-4117-11PA1003
 STORAGE -----DRAWING 19-48-4118-1-2-3-4-14-22PA1002
- F. FOR METHOD OF SECURING A STRAP CUTTER TO THE PALLET UNIT, SEE DARCOM DRAWING 19-48-4127-20P1000.
- G. IF ITEMS COVERED HEREIN ARE UNITIZED PRIOR TO ISSUANCE OF THIS APPENDIX, THE BOXES NEED NOT BE REUNITIZED SOLELY TO CONFORM TO THIS APPENDIX.
- H. THE UNITIZATION PROCEDURES DEPICTED HEREIN MAY ALSO BE USED FOR UNITIZING CARTRIDGE ACTUATED CUTTERS WHEN IDENTIFIED BY DIFFERENT NATIONAL STOCK NUMBERS (NSN) THAN WHAT IS SHOWN ON THE TITLE PAGE, PROVIDED THE BOX PACK DOES NOT VARY FROM WHAT IS DELINEATED HEREIN. THE EXPLOSIVE CLASSIFICATION OF OTHER ITEMS MAY BE DIFFERENT THAN WHAT IS SHOWN.

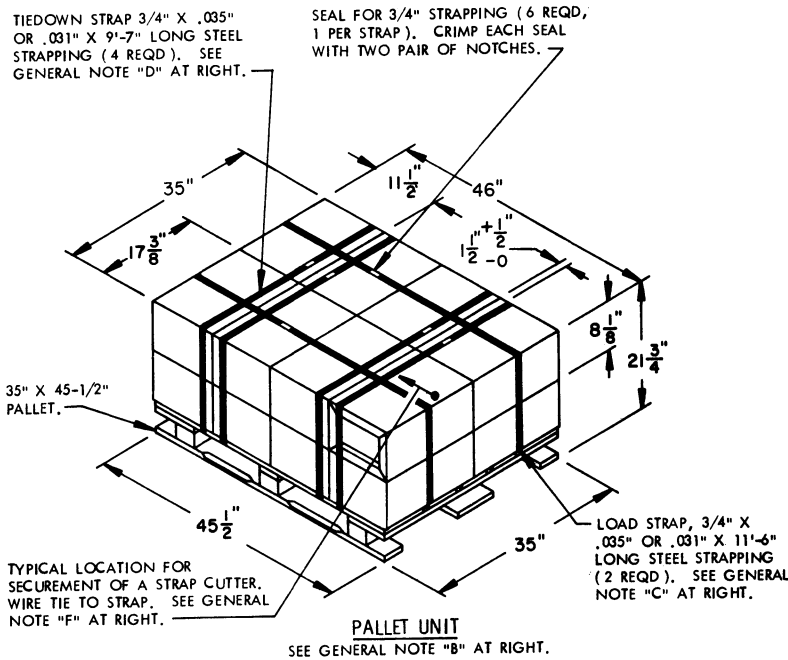

16 BOXES OF CUTTER, CARTRIDGE ACTUATED (40 PER BOX) @ 35 LBS	---	560 LBS (APPROX)
DUNNAGE	-----	5 LBS
PALLET	-----	65 LBS
TOTAL WEIGHT		----- 630 LBS (APPROX)
CUBE		----- 20.3 CU FT (APPROX)

BILL OF MATERIAL		
PALLET, 35" X 45-1/2"	----- 1 REQD	----- 65 LBS
STEEL STRAPPING, 3/4"	-----61.33' REQD	-----4.38 LBS
SEAL FOR 3/4" STRAPPING	----- 6 REQD	----- NIL

