

APPENDIX 146B

UNITIZATION PROCEDURES FOR BOXED AMMUNITION AND COMPONENTS ON 4-WAY ENTRY PALLETS

CUTTER, CARTRIDGE ACTUATED, M2, PACKED 100
PER WOODEN BOX, UNITIZED 32 BOXES PER 35"
X 45 $\frac{1}{2}$ " PALLET; APPROX BOX SIZE 17 $\frac{1}{2}$ " L X
12 $\frac{3}{4}$ " W X 9 $\frac{1}{2}$ " H

PALLET UNIT DATA						
ITEMS INCLUDED		HAZARD CLASSIFICATION				WEIGHT
NSN	DODIC	DOT CLASS	CG CLASS	QD CLASS	COMP GROUP	(LBS)
1377-00-028-5412	M504	C	I	1.4	S	1,768

NOTICE: THIS APPENDIX CANNOT STAND ALONE BUT MUST BE USED IN CONJUNCTION WITH THE BASIC UNITIZATION PROCEDURES DRAWING 19-48-4116-20PA1002.

REVISIONS				DRAFTSMAN <i>RJB</i>	PROJ ENG <i>8/8/79/RLW</i>
				CHECKER <i>RSN</i>	LOG ENGRG OFFICE <i>John Boyd</i>
APPROVED, U. S. ARMY ARMAMENT MATERIEL READINESS COMMAND					
<i>John L. Boyd</i>					
DRBAR - MAD			DRBAR - TMD		
APPROVED BY ORDER OF COMMANDING GENERAL, U. S. ARMY MATERIEL DEVELOPMENT AND READINESS COMMAND (DARCOM)					
<i>John L. Boyd</i>					
U. S. ARMY DEFENSE AMMUNITION CENTER AND SCHOOL					
U. S. ARMY DARCOM DRAWING					
JULY 1980					
CLASS	DIVISION	DRAWING	FILE		
19	48	4116/ 146B	20PA 1002		

DO NOT SCALE

SEAL FOR 3/4" STRAPPING (6 REQ'D, 1 PER STRAP), CRIMP EACH SEAL WITH TWO PAIR OF NOTCHES.

TIEDOWN STRAP, 3/4" X .035" OR .031" X 13'-3" LONG STEEL STRAPPING (4 REQ'D). SEE GENERAL NOTE "D" AT RIGHT.

TOP CLEATS ON THE BOXES IN THE OUTWARD STACKS WILL BE TURNED INWARD.

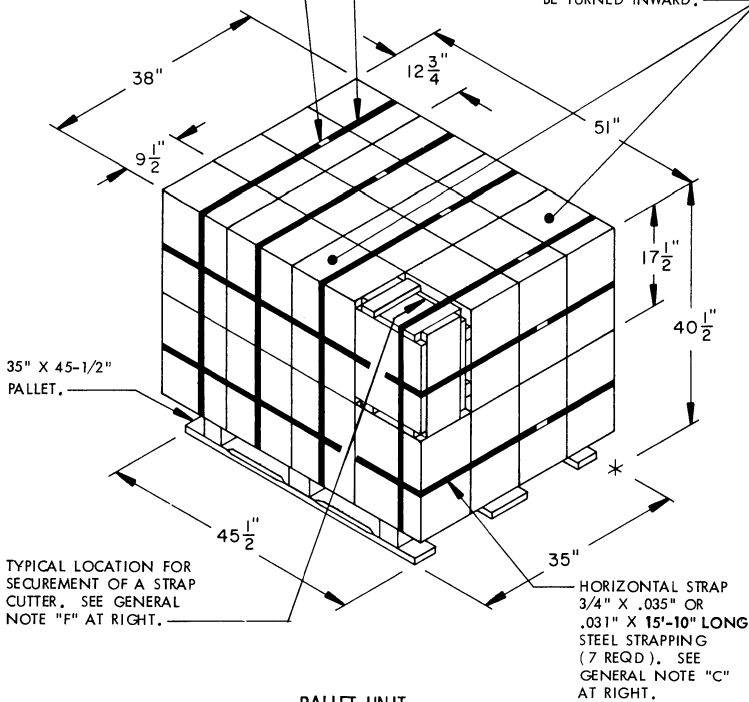

PALLET UNIT

SEE GENERAL NOTE "B" AT RIGHT.

32 BOXES OF CUTTER, CARTRIDGE ACTUATED (100 PER BOX) @ 53 LBS -- 1,696 LBS (APPROX)
 DUNNAGE ----- 7 LBS
 PALLET ----- 65 LBS

TOTAL WEIGHT ----- 1,768 LBS (APPROX)
 CUBE ----- 45.4 CU FT (APPROX)

BILL OF MATERIAL

PALLET, 35" X 45-1/2" -----	1 REQ'D -----	65 LBS
STEEL STRAPPING, 3/4" -----	84.67 REQ'D -----	6.05 LBS
SEAL FOR 3/4" STRAPPING ---	6 REQ'D -----	NIL

TIE PIECE, 1" X 4" X BOX HEIGHT (2 REQ'D). NAIL TO LONGITUDINAL PIECES W/2-6d NAILS AT EACH END AND TO LATERAL PIECE W/1-6d NAIL.

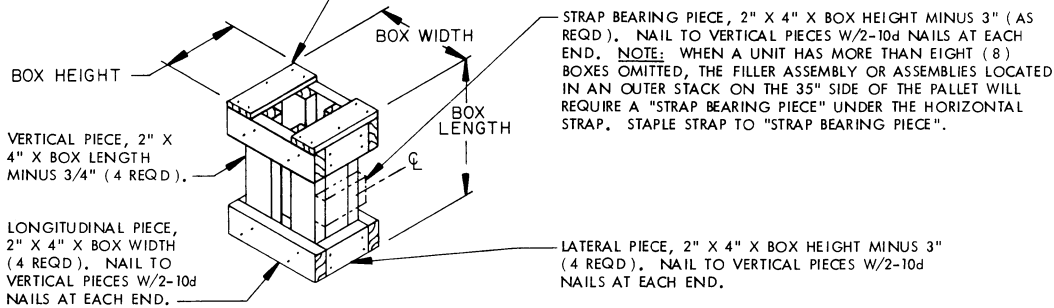

FILLER ASSEMBLY

(FOR MINUS ONE BOX)

GENERAL NOTES

- A. THIS APPENDIX CANNOT STAND ALONE BUT MUST BE USED IN CONJUNCTION WITH THE BASIC UNITIZATION PROCEDURES DRAWING 19-48-4116-20PA1002. TO PRODUCE AN APPROVED UNIT LOAD, ALL PERTINENT PROCEDURES, SPECIFICATIONS AND CRITERIA SET FORTH WITHIN THE BASIC DRAWING WILL APPLY TO THE PROCEDURES DELINEATED IN THIS APPENDIX. ANY EXCEPTIONS TO THE BASIC PROCEDURES ARE SPECIFIED IN THIS APPENDIX.
- B. DIMENSIONS, CUBE AND WEIGHT OF A PALLET UNIT WILL VARY SLIGHTLY DEPENDING UPON THE ACTUAL DIMENSIONS OF THE BOXES AND THE WEIGHT OF THE SPECIFIC ITEM BEING UNITIZED.
- C. INSTALL EACH HORIZONTAL STRAP TO ENCIRCLE A LAYER OF BOXES ON THE PALLET. HORIZONTAL STRAPS MUST BE TENSIONED AND SEALED PRIOR TO APPLICATION OF TIEDOWN STRAPS.
- D. INSTALL EACH TIEDOWN STRAP TO PASS UNDER THE DECK/STRINGER BOARDS OF THE PALLET AND TO BE LOCATED AS SHOWN. TIEDOWN STRAPS WILL NOT BE APPLIED UNTIL THE HORIZONTAL STRAPS HAVE BEEN TENSIONED AND SEALED.
- E. THE FOLLOWING DARCOM DRAWINGS ARE APPLICABLE FOR OUTLOADING AND STORAGE OF THE ITEMS COVERED BY THIS APPENDIX.
 CARLOADING ----- DRAWING 19-48-4115-5PA1002
 TRUCKLOADING ----- DRAWING 19-48-4117-11PA1003
 STORAGE ----- DRAWING 19-48-4118-1-2-14-22PA1002
- F. FOR METHOD OF SECURING A STRAP CUTTER TO THE PALLET UNIT, SEE DARCOM DRAWING 19-48-4127-20P1000.
- G. IF ITEMS COVERED HEREIN ARE UNITIZED PRIOR TO ISSUANCE OF THIS APPENDIX, THE BOXES NEED NOT BE REUNITIZED SOLELY TO CONFORM TO THIS APPENDIX.
- H. THE UNITIZATION PROCEDURES DEPICTED HEREIN MAY ALSO BE USED FOR UNITIZING CUTTERS, CARTRIDGE ACTUATED, WHEN IDENTIFIED BY DIFFERENT NATIONAL STOCK NUMBERS (NSN) THAN WHAT IS SHOWN ON THE TITLE PAGE, PROVIDED THE BOX PACK DOES NOT VARY FROM WHAT IS DELINEATED HEREIN. THE EXPLOSIVE CLASSIFICATION OF OTHER ITEMS MAY BE DIFFERENT THAN WHAT IS SHOWN.