

APPENDIX 141A

UNITIZATION PROCEDURES FOR BOXED AMMUNITION AND COMPONENTS ON 4 - WAY ENTRY PALLETS

BULK EXPLOSIVES, PACKED IN M18 WOODEN BOX,
UNITIZED 36 BOXES PER 40" X 48" PALLET;
APPROX BOX SIZE 13 $\frac{5}{8}$ " L X 13 $\frac{5}{8}$ " W X 13 $\frac{5}{8}$ " H

PALLET UNIT DATA						
ITEMS INCLUDED		HAZARD CLASSIFICATION ①				WEIGHT (LBS)
NSN	DODIC	DOT CLASS	CG CLASS	QD CLASS	COMP GROUP	
UN- ASSIGNED						2,536

REVISION

REVISION NO. 1, DATED SEPTEMBER 1986, CONSISTS OF:

1. CHANGING BOX DIMENSIONS.
2. UPDATING PALLET UNIT TO CONFORM TO 1. ABOVE.

REVISION NO. 2, DATED OCTOBER 1987, CONSISTS OF:

ADDING GENERAL NOTE "K".

NOTICE: THIS APPENDIX CANNOT STAND ALONE BUT MUST BE USED IN CONJUNCTION WITH THE BASIC UNITIZATION PROCEDURES DRAWING 19-48-4116-20PA1002.

① HAZARD CLASSIFICATION DATA CONTAINED IN THE ABOVE CHART IS FOR GUIDANCE AND INFORMATIONAL PURPOSES ONLY. VERIFICATION OF THE SPECIFIED DATA SHOULD BE MADE BY CONSULTING THE MOST RECENT JOINT HAZARD CLASSIFICATION SYSTEM LISTING OR OTHER APPROVED LISTING (S).

DO NOT SCALE

REVISIONS		DRAFTSMAN Durr / dh	PROJ ENG LAF / mnd
1	SEP 86	WIFE WIFE WIFE <i>John Boyd</i> SMCAR-ESK / AMBNC-TMD	R23 LOG ENG/OFFICE <i>John Boyd</i> SMCAR-ESK / AMBNC-TMD
2	OCT 87	WIFE WIFE WIFE <i>William F. Ernst</i> SMCAR-ESK / AMBNC-TMD	<i>John Boyd</i> SMCAR-ESK / AMBNC-TMD
APPROVED BY ORDER OF COMMANDING GENERAL, U.S. ARMY MATERIEL COMMAND (AMC)			
<i>John L. Byrd</i> U.S. ARMY DEFENSE AMMUNITION CENTER AND SCHOOL			
U.S. ARMY AMC DRAWING			
JANUARY 1986			
CLASS	DIVISION	DRAWING	FILE
19	48	4116/ 141A	20PA 1002

GENERAL NOTES

- A. THIS APPENDIX CANNOT STAND ALONE BUT MUST BE USED IN CONJUNCTION WITH THE BASIC UNITIZATION PROCEDURES DRAWING 19-48-4116-20PA1002. TO PRODUCE AN APPROVED UNIT LOAD, ALL PERTINENT PROCEDURES, SPECIFICATIONS AND CRITERIA SET FORTH WITHIN THE BASIC DRAWING WILL APPLY TO THE PROCEDURES DELINEATED IN THIS APPENDIX. ANY EXCEPTIONS TO THE BASIC PROCEDURES ARE SPECIFIED IN THIS APPENDIX.
- B. DIMENSIONS, CUBE AND WEIGHT OF A PALLET UNIT WILL VARY SLIGHTLY DEPENDING UPON THE ACTUAL DIMENSIONS OF THE BOXES AND THE WEIGHT OF THE SPECIFIC ITEM BEING UNITIZED.
- C. INSTALL EACH HORIZONTAL STRAP TO ENCIRCLE A LAYER OF BOXES ON THE PALLET. HORIZONTAL STRAPS MUST BE TENSIONED AND SEALED PRIOR TO THE APPLICATION OF TIEDOWN STRAPS.
- D. INSTALL EACH TIEDOWN STRAP TO PASS UNDER THE DECK/STRINGER BOARDS OF THE PALLET. TIEDOWN STRAPS WILL NOT BE APPLIED UNTIL THE HORIZONTAL STRAPS HAVE BEEN TENSIONED AND SEALED.
- E. THE FOLLOWING AMC (DARCOM) DRAWINGS ARE APPLICABLE FOR OUTLOADING AND STORAGE OF THE ITEMS COVERED BY THIS APPENDIX.
 CARLOADING ----- DRAWING 19-48-4115-5PA1002
 TRUCKLOADING ----- DRAWING 19-48-4117-11PA1003
 STORAGE ----- DRAWING 19-48-4118-1-2-3-4-14-22PA1002
- F. FOR METHODS OF SECURING A STRAP CUTTER TO THE PALLET UNIT, SEE DARCOM DRAWING 19-48-4127-20P1000.
- G. IF ITEMS COVERED HEREIN ARE UNITIZED PRIOR TO ISSUANCE OF THIS APPENDIX, THE BOXES NEED NOT BE REUNITIZED SOLELY TO CONFORM TO THIS APPENDIX.
- H. THE UNITIZATION PROCEDURES DEPICTED HEREIN MAY ALSO BE USED FOR UNITIZING BULK EXPLOSIVES WHEN IDENTIFIED BY DIFFERENT NATIONAL STOCK NUMBERS (NSN) THAN WHAT IS SHOWN ON THE TITLE PAGE, PROVIDED THE BOX PACK DOES NOT VARY FROM WHAT IS DELINEATED HEREIN. THE EXPLOSIVE CLASSIFICATION OF OTHER ITEMS MAY BE DIFFERENT THAN WHAT IS SHOWN.
- J. WHEN THE UNIT LOAD DEPICTED AT LEFT IS TO BE USED FOR UNITIZING MARINE CORPS AMMUNITION, ONE LAYER OF BOXES MUST BE OMITTED, TIEDOWN STRAP LENGTHS MUST BE DECREASED TO 12'-6", AND ONE HORIZONTAL STRAP MUST BE OMITTED. THIS WILL RESULT IN AN OVERALL UNIT HEIGHT OF 32'-3/4", A GROSS UNIT WEIGHT OF 1,718 POUNDS, AND A UNIT CUBE OF 42.2 CUBIC FEET. ADDITIONALLY, THE UNIT LOAD MAY BE MODIFIED AS DESCRIBED WHEN BEING SHIPPED BY MILVAN OR COMMERCIAL INTERMODAL FREIGHT CONTAINER. THE DETERMINATION TO REDUCE THE LOAD BY A LAYER FOR TRANSPORTATION WILL BE MADE BY THE RESPONSIBLE COMMAND AND WILL BE BASED UPON ECONOMICS OF TRANSPORTATION AND HANDLING.
- K. THE STYLE 1 PALLET DELINEATED IN THE DETAIL AT LEFT NEED NOT HAVE CHAMFERS OR STRAP SLOTS AS SPECIFIED WITHIN MILITARY SPECIFICATION MIL-P-15011 WHEN USED FOR THE UNITIZATION OF THE ITEMS COVERED BY THIS APPENDIX.

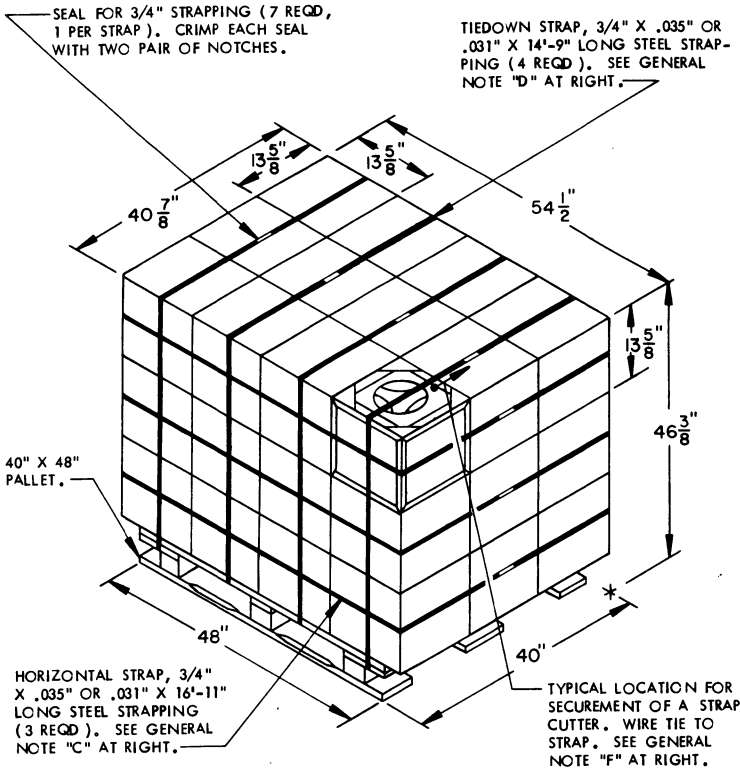

PALLET UNIT

SEE GENERAL NOTE "B" AT RIGHT.

36 BOXES OF BULK EXPLOSIVES @ 68 LBS	-----	2,448 LBS (APPROX)
DUNNAGE	-----	8 LBS
PALLET	-----	80 LBS
TOTAL WEIGHT	-----	2,536 LBS (APPROX)
CUBE	-----	59.8 CU FT

BILL OF MATERIAL

PALLET, 40" X 48"	-----	1 REQD	-----	80 LBS
STEEL STRAPPING, 3/4"	-----	109.75' REQD	-----	7.84 LBS
SEAL FOR 3/4" STRAPPING	-----	7 REQD	-----	NIL

