

APPENDIX 138

UNITIZATION PROCEDURES FOR BOXED AMMUNITION AND COMPONENTS ON 4 - WAY ENTRY PALLETS

CANINE EXPLOSIVE SCENT KIT, PACKED 1 PER
WOODEN BOX, UNITIZED 16 BOXES PER
35" X 45 $\frac{1}{2}$ " PALLET; APPROX BOX SIZE
35" L X 12 $\frac{3}{4}$ " W X 10 $\frac{1}{2}$ " H

PALLET UNIT DATA						
ITEMS INCLUDED		HAZARD CLASSIFICATION ①				WEIGHT (LBS)
NSN	DODIC	DOT CLASS	CG CLASS	QD CLASS	COMP GROUP	
1375- 01-192-741	UNAS	A	IX-B	1,1	D	1,352

① HAZARD CLASSIFICATION DATA CONTAINED IN THE ABOVE CHART IS FOR GUIDANCE AND INFORMATIONAL PURPOSES ONLY. VERIFICATION OF THE SPECIFIED DATA SHOULD BE MADE BY CONSULTING THE MOST RECENT JOINT HAZARD CLASSIFICATION SYSTEM LISTING OR OTHER APPROVED LISTING(S).

NOTICE: THIS APPENDIX CANNOT STAND ALONE BUT MUST BE USED IN CONJUNCTION WITH THE BASIC UNITIZATION PROCEDURES DRAWING 19-48-4116-20PA1002.

REVISIONS				DRAFTSMAN <i>Durr</i>	pt	PROJ ENG <i>LAF/WRF</i>	
				<i>Durr</i>		<i>LAF/WRF</i>	
				<i>Durr</i>		<i>LAF/WRF</i>	
				<small>APPROVED, U.S. ARMY ARMAMENT, MUNITIONS AND CHEMICAL COMMAND</small> <small>BY</small> <i>Walter B. Holcomb</i> <i>Dan H. Kell</i> <small>SAC/AMC - TMD</small> <small>AMSMC - TMD</small>			
				<small>APPROVED BY ORDER OF COMMANDING GENERAL, U.S. ARMY MATERIEL COMMAND (AMC)</small> <i>John J. Byrnes</i> <small>U.S. ARMY DEFENSE AMMUNITION CENTER AND SCHOOL</small>			
				U.S. ARMY AMC DRAWING			
				MAY 1989			
				CLASS	DIVISION	DRAWING	FILE
				19	48	4116/ 138	20PA 1002

DO NOT SCALE

TIEDOWN STRAP, 3/4" X .035" OR .031" X 13'-11" (4 REQD.). SEE GENERAL NOTE "D" AT RIGHT.

SEAL FOR 3/4" STRAPPING (6 REQD., 1 PER STRAP). CRIMP EACH SEAL WITH TWO PAIR OF NOTCHES.

LOAD STRAP, 3/4" X .035" OR .031" X 16'-7" (2 REQD.). SEE GENERAL NOTE "C" AT RIGHT.

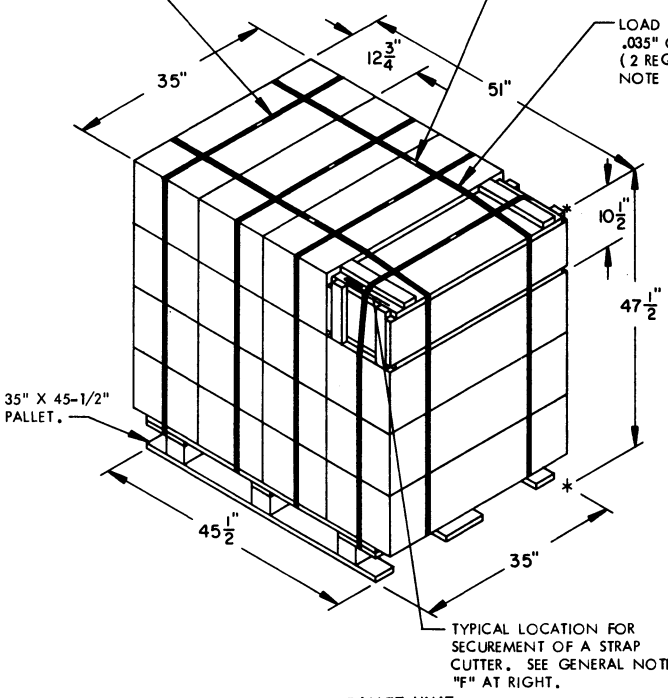

PALLET UNIT

SEE GENERAL NOTE "B" AT RIGHT.

16 BOXES OF CANINE EXPLOSIVE SCENT KIT (1 PER BOX) @ 80 LBS	-----	1,280 LBS (APPROX)
DUNNAGE	-----	7 LBS
PALLET	-----	65 LBS
TOTAL WEIGHT	-----	1,352 LBS (APPROX)
CUBE	-----	49.1 CU FT (APPROX)

BILL OF MATERIAL

PALLET, 35" X 45-1/2"	-----	1 REQD	-----	65 LBS
STEEL STRAPPING, 3/4"	-----	88.83 REQD	-----	6.35 LBS
SEAL FOR 3/4" STRAPPING	-----	6 REQD	-----	NIL

GENERAL NOTES

- A. THIS APPENDIX CANNOT STAND ALONE BUT MUST BE USED IN CONJUNCTION WITH THE BASIC UNITIZATION PROCEDURES DRAWING 19-48-4116-20PA1002. TO PRODUCE AN APPROVED UNIT LOAD, ALL PERTINENT PROCEDURES, SPECIFICATIONS AND CRITERIA SET FORTH WITHIN THE BASIC DRAWING WILL APPLY TO THE PROCEDURES DELINEATED IN THIS APPENDIX. ANY EXCEPTIONS TO THE BASIC PROCEDURES ARE SPECIFIED IN THIS APPENDIX.
- B. DIMENSIONS, CUBE, AND WEIGHT OF A PALLET UNIT WILL VARY SLIGHTLY DEPENDING UPON THE ACTUAL DIMENSIONS OF THE BOXES AND THE WEIGHT OF THE SPECIFIC ITEM BEING UNITIZED.
- C. THE LOAD STRAPS MAY BE THREADED THRU THE STRAP SLOTS OF A PALLET OR PRE-POSITIONED ON THE PALLET DECK PRIOR TO PLACING BOXES ON THE PALLET. LOAD STRAPS MUST BE TENSIONED AND SEALED PRIOR TO APPLICATION OF TIEDOWN STRAPS.
- D. INSTALL EACH TIEDOWN STRAP TO PASS UNDER THE DECK/STRINGER BOARDS OF THE PALLET AND TO BE LOCATED AS SHOWN. TIEDOWN STRAPS WILL NOT BE APPLIED UNTIL THE LOAD STRAPS HAVE BEEN TENSIONED AND SEALED.
- E. THE FOLLOWING AMC (DARCOM) DRAWINGS ARE APPLICABLE FOR OUTLOADING AND STORAGE OF THE ITEMS COVERED BY THIS APPENDIX.
 CARLOADING ----- DRAWING 19-48-4115-5PA1002.
 TRUCKLOADING ----- DRAWING 19-48-4117-11PA1003.
 STORAGE ----- DRAWING 19-48-4118-1-2-3-4-14-22PA1002.
- F. FOR METHOD OF SECURING A STRAP CUTTER TO THE PALLET UNIT, SEE DARCOM DRAWING 19-48-4127-20P1000.
- G. IF ITEMS COVERED HEREIN ARE UNITIZED PRIOR TO ISSUANCE OF THIS APPENDIX, THE BOXES NEED NOT BE REUNITIZED SOLELY TO CONFORM TO THIS APPENDIX.
- H. THE UNITIZATION PROCEDURES DEPICTED HEREIN MAY ALSO BE USED FOR UNITIZING CANINE EXPLOSIVE SCENT KITS WHEN IDENTIFIED BY DIFFERENT NATIONAL STOCK NUMBERS (NSN) THAN WHAT IS SHOWN ON THE TITLE PAGE, PROVIDED THE BOX PACK DOES NOT VARY FROM WHAT IS DELINEATED HEREIN. THE EXPLOSIVE CLASSIFICATION OF OTHER ITEMS MAY BE DIFFERENT THAN WHAT IS SHOWN.
- J. WHEN THE UNIT LOAD DEPICTED AT LEFT IS TO BE USED FOR UNITIZING MARINE CORPS AMMUNITION, ONE LAYER OF BOXES MUST BE OMITTED, TIEDOWN STRAP LENGTHS MUST BE DECREASED TO 12'-2" AND LOAD STRAP LENGTHS MUST BE DECREASED TO 14'-10". THIS WILL RESULT IN AN OVERALL UNIT HEIGHT OF 37", A GROSS WEIGHT OF 1,031 POUNDS, AND A UNIT CUBE OF 38.2 CUBIC FEET. ADDITIONALLY, THE UNIT MAY BE MODIFIED AS DESCRIBED WHEN BEING SHIPPED BY MILVAN OR COMMERCIAL INTERMODAL FREIGHT CONTAINER. THE DETERMINATION TO REDUCE THE LOAD BY A LAYER FOR TRANSPORTATION WILL BE MADE BY THE RESPONSIBLE COMMAND AND WILL BE BASED UPON ECONOMICS OF TRANSPORTATION AND HANDLING.
- K. THE STYLE 1A PALLET DELINEATED IN THE DETAIL AT LEFT NEED NOT HAVE CHAMFERS OR STRAP SLOTS AS SPECIFIED WITHIN MILITARY SPECIFICATION MIL-P-15011 WHEN USED FOR THE UNITIZATION OF ITEMS COVERED BY THIS APPENDIX.

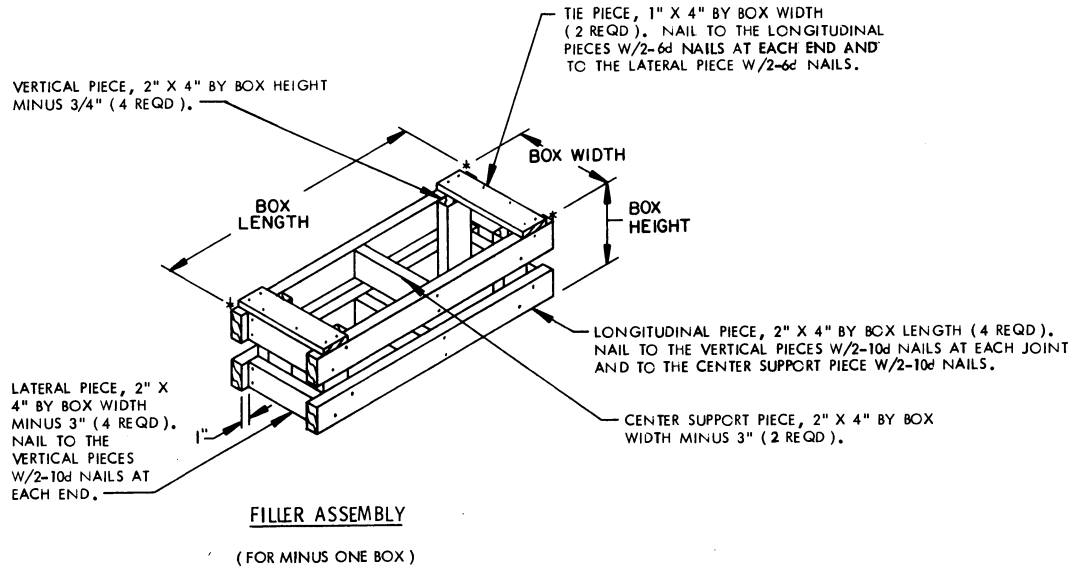

FILLER ASSEMBLY

(FOR MINUS ONE BOX)