

TYPICAL LOCATION FOR SECUREMENT OF A STRAP CUTTER. SEE GENERAL NOTE "F" AT RIGHT.

TIEDOWN STRAP, 3/4" X .035" OR .031" X 11'-4" LONG STEEL STRAPPING (2 REQD). SEE GENERAL NOTE "D" AT RIGHT.

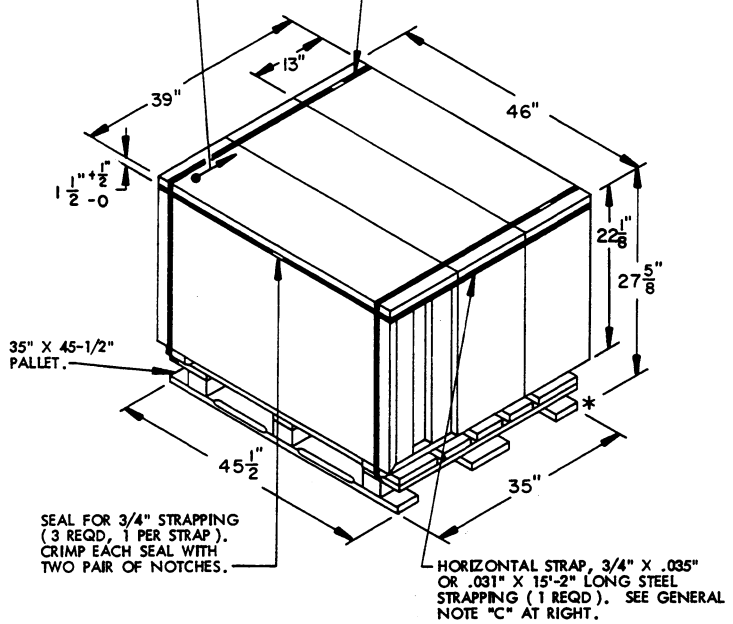

GENERAL NOTES

- A. THIS APPENDIX CANNOT STAND ALONE BUT MUST BE USED IN CONJUNCTION WITH THE BASIC UNITIZATION PROCEDURES DRAWING 19-48-4116-20PA1002. TO PRODUCE AN APPROVED UNIT LOAD, ALL PERTINENT PROCEDURES, SPECIFICATIONS AND CRITERIA SET FORTH WITHIN THE BASIC DRAWING WILL APPLY TO THE PROCEDURES DELINEATED IN THIS APPENDIX. ANY EXCEPTIONS TO THE BASIC PROCEDURES ARE SPECIFIED IN THIS APPENDIX.
- B. DIMENSIONS, CUBE AND WEIGHT OF A PALLET UNIT WILL VARY SLIGHTLY DEPENDING UPON THE ACTUAL DIMENSIONS OF THE BOXES AND THE WEIGHT OF THE SPECIFIC ITEM BEING UNITIZED.
- C. INSTALL THE HORIZONTAL STRAP TO ENCIRCLE THE LAYER OF BOXES ON THE PALLET. NOTE THAT THE STRAP WILL BE LOCATED AS DIMENSIONED, NEAR THE TOP OF THE BOXES. HORIZONTAL STRAP MUST BE TENSIONED AND SEALED PRIOR TO APPLICATION OF TIE-DOWN STRAPS.
- D. INSTALL EACH TIEDOWN STRAP TO PASS UNDER THE STRINGER BOARDS OF THE PALLET AND TO BE LOCATED AS SHOWN. TIEDOWN STRAPS WILL NOT BE APPLIED UNTIL THE HORIZONTAL STRAP HAS BEEN TENSIONED AND SEALED.
- E. THE FOLLOWING DARCOM DRAWINGS ARE APPLICABLE FOR OUTLOAD-IN AND STORAGE OF THE ITEMS COVERED BY THIS APPENDIX.
 CARLOADING-----DRAWING 19-48-4115-5PA1002
 TRUCKLOADING-----DRAWING 19-48-4117-11PA1003
 STORAGE-----DRAWING 19-48-4118-1-14-22PA1002
- F. FOR METHOD OF SECURING A STRAP CUTTER TO THE PALLET UNIT, SEE DARCOM DRAWING 19-48-4127-20P1000.
- G. IF ITEMS COVERED HEREIN ARE UNITIZED PRIOR TO ISSUANCE OF THIS APPENDIX, THE BOXES NEED NOT BE REUNITIZED SOLELY TO CONFORM TO THIS APPENDIX.
- H. THE UNITIZATION PROCEDURES DEPICTED HEREIN MAY ALSO BE USED FOR UNITIZING DEMOLITION KITS WHEN IDENTIFIED BY DIFFERENT NATIONAL STOCK NUMBERS (NSN) THAN WHAT IS SHOWN ON THE TITLE PAGE, PROVIDED THE BOX PACK DOES NOT VARY FROM WHAT IS DELINEATED HEREIN. THE EXPLOSIVE CLASSIFICATION OF OTHER ITEMS MAY BE DIFFERENT THAN WHAT IS SHOWN.

PALLET UNIT

SEE GENERAL NOTE "B" AT RIGHT.

3 BOXES OF DEMOLITION KITS (1 PER BOX) @ 147 LBS -----	441 LBS (APPROX)
DUNNAGE -----	3 LBS
PALLET -----	65 LBS
TOTAL WEIGHT -----	509 LBS (APPROX)
CUBE -----	28.7 CU FT (APPROX)

BILL OF MATERIAL

PALLET, 35" X 45-1/2" -----	1 REQD ---	65 LBS
STEEL STRAPPING, 3/4" -----	37.83' REQD ---	2.70 LBS
SEAL FOR 3/4" STRAPPING -----	3 REQD ---	NIL

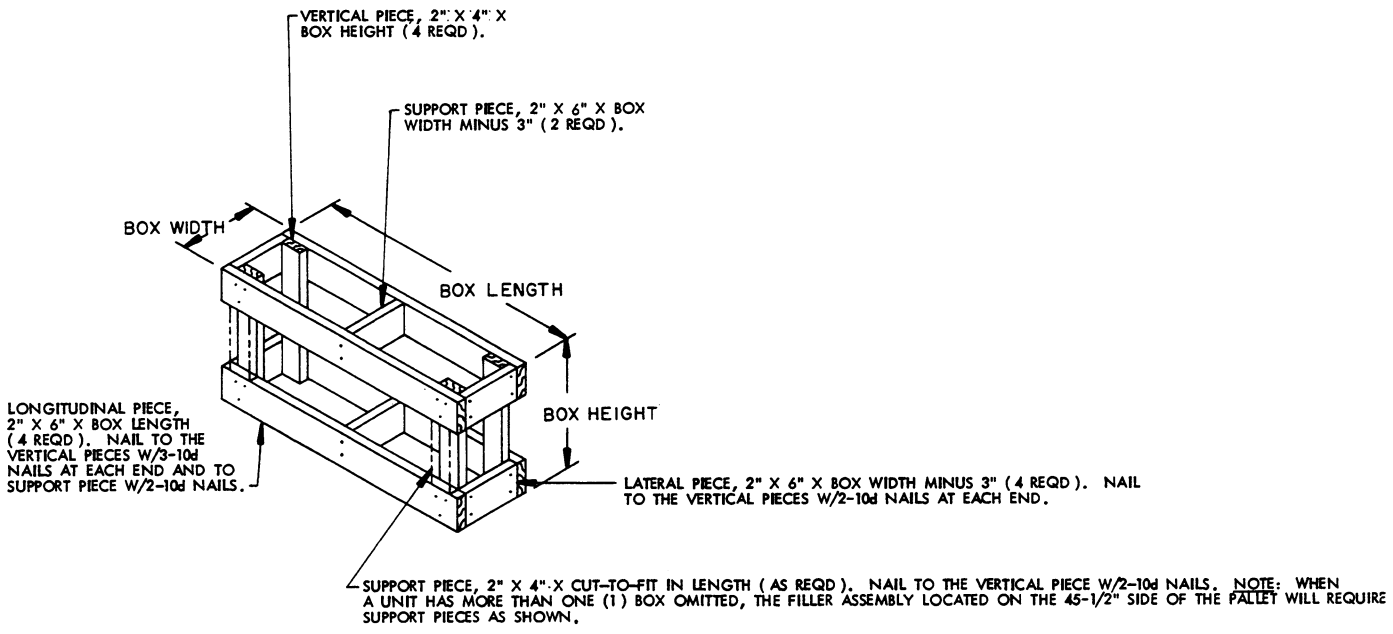

FILLER ASSEMBLY
(FOR MINUS ONE BOX)