

APPENDIX 135

UNITIZATION PROCEDURES FOR BOXED AMMUNITION AND COMPONENTS ON 4-WAY ENTRY PALLETS

SHAPE CHARGE, PACKED 4 PER WIREBOUND BOX,
UNITIZED 60 BOXES PER 40" X 48" PALLET;
APPROX BOX SIZE 14 $\frac{5}{8}$ " L X 12 $\frac{3}{4}$ " W X 9 $\frac{1}{8}$ " H

PALLET UNIT DATA						
ITEMS INCLUDED		HAZARD CLASSIFICATION [Ⓢ]				WEIGHT
NSN	DODIC	DOT CLASS	CG CLASS	QD CLASS	COMP GROUP	(LBS)
1375-01-004-1083	M832	A	IX-B	1.1	D	1,649

Ⓢ HAZARD CLASSIFICATION DATA CONTAINED IN THE ABOVE CHART IS FOR GUIDANCE AND INFORMATIONAL PURPOSES ONLY. VERIFICATION OF THE SPECIFIED DATA SHOULD BE MADE BY CONSULTING THE MOST RECENT JOINT HAZARD CLASSIFICATION SYSTEM LISTING OR OTHER APPROVED LISTING(S).

DO NOT SCALE

NOTICE: THIS APPENDIX CANNOT STAND ALONE BUT MUST BE USED IN CONJUNCTION WITH THE BASIC UNITIZATION PROCEDURES DRAWING 19-48-4116-20PA1002.

REVISIONS				DRAFTSMAN P.B.	PROJ ENG
				CHECKER R-18	LOG ENGINE OFFICE
				APPROVED, U. S. ARMY ARMAMENT, MUNITIONS AND CHEMICAL COMMAND	
				DRBMC-LEP	DRBMC-TMB
				APPROVED BY ORDER OF COMMANDING GENERAL, U. S. ARMY MATERIEL DEVELOPMENT AND READINESS COMMAND (DARCOM)	
				U. S. ARMY DEFENSE AMMUNITION CENTER AND SCHOOL	
				U. S. ARMY DARCOM DRAWING	
				NOVEMBER 1983	
				CLASS	DIVISION
				DRAWING	FILE
				19	48
				4116/135	20PA 1002

SEAL FOR 3/4" STRAPPING
(7 REQ'D, 1 PER STRAP).
CRIMP EACH SEAL WITH TWO
PAIR OF NOTCHES.

TIEDOWN STRAP, 3/4" X .035" OR .031"
X 16'-0" LONG STEEL STRAPPING (4 REQ'D).
SEE GENERAL NOTE "D" AT RIGHT.

GENERAL NOTES

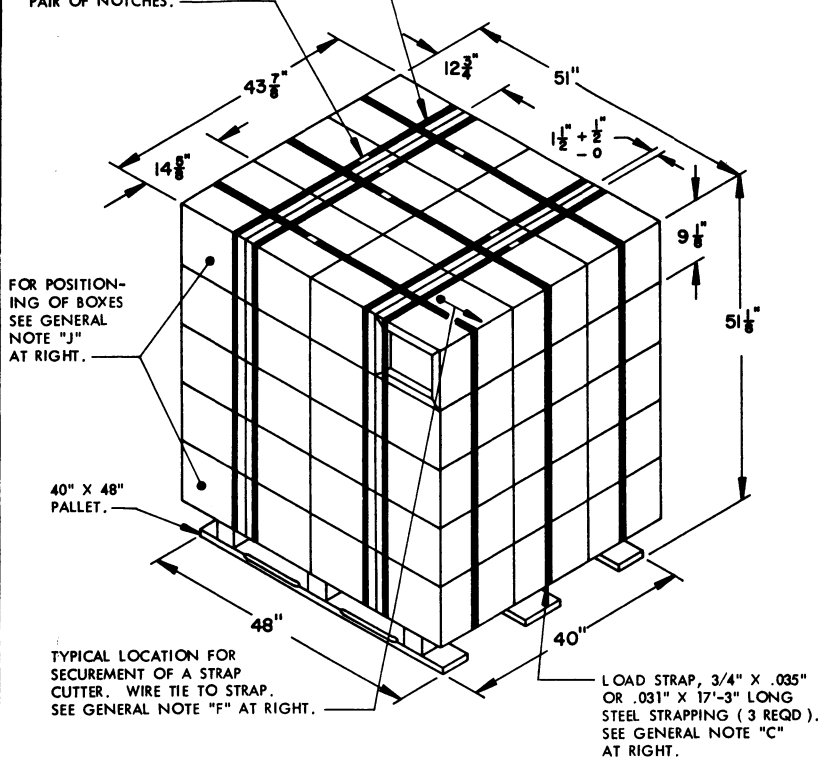

PALLET UNIT

SEE GENERAL NOTE "B" AT RIGHT.

60 BOXES OF SHAPE CHARGES (4 PER BOX) @ 26 LBS	-----	1,560 LBS (APPROX)
DUNNAGE	-----	9 LBS
PALLET	-----	80 LBS
TOTAL WEIGHT	-----	1,649 LBS (APPROX)
CUBE	-----	66.2 CU FT (APPROX)

BILL OF MATERIAL

PALLET, 40" X 48" -----	1 REQ'D -----	80 LBS
STEEL STRAPPING, 3/4" -----	115.75' REQ'D -----	8.27 LBS
SEAL FOR 3/4" STRAPPING -----	7 REQ'D -----	NIL

- A. THIS APPENDIX CANNOT STAND ALONE BUT MUST BE USED IN CONJUNCTION WITH THE BASIC UNITIZATION PROCEDURES DRAWING 19-48-4116-20PA1002. TO PRODUCE AN APPROVED UNIT LOAD, ALL PERTINENT PROCEDURES, SPECIFICATIONS AND CRITERIA SET FORTH WITHIN THE BASIC DRAWING WILL APPLY TO THE PROCEDURES DELINEATED IN THIS APPENDIX. ANY EXCEPTIONS TO THE BASIC PROCEDURES ARE SPECIFIED IN THIS APPENDIX.
- B. DIMENSIONS, CUBE AND WEIGHT OF A PALLET UNIT WILL VARY SLIGHTLY DEPENDING UPON THE ACTUAL DIMENSIONS OF THE BOXES AND THE WEIGHT OF THE SPECIFIC ITEM BEING UNITIZED.
- C. THE LOAD STRAPS MAY BE THREADED THROUGH THE STRAP SLOTS OF A PALLET OR PRE-POSITIONED ON THE PALLET DECK PRIOR TO PLACING BOXES ON THE PALLET. LOAD STRAPS MUST BE TENSIONED AND SEALED PRIOR TO APPLICATION OF TIEDOWN STRAPS.
- D. INSTALL EACH TIEDOWN STRAP TO PASS UNDER THE TOP DECK BOARDS OF THE PALLET. NOTE THAT THE STRAPS WILL BE LOCATED AS DIMENSIONED, NEAR THE SIDE CLEATS OF THE END PANELS OF THE BOX. TIEDOWN STRAPS WILL NOT BE APPLIED UNTIL THE LOAD STRAPS HAVE BEEN TENSIONED AND SEALED.
- E. THE FOLLOWING DARCOM DRAWINGS ARE APPLICABLE FOR OUTLOADING AND STORAGE OF THE ITEMS COVERED BY THIS APPENDIX.

CARLOADING -----	DRAWING 19-48-4115-5PA1002
TRUCKLOADING -----	DRAWING 19-48-4117-11PA1003
STORAGE -----	DRAWING 19-48-4118-1-2-3-4-14-22PA1002
- F. FOR METHOD OF SECURING A STRAP CUTTER TO THE PALLET UNIT, SEE DARCOM DRAWING 19-48-4127-20P1000.
- G. IF ITEMS COVERED HEREIN ARE UNITIZED PRIOR TO ISSUANCE OF THIS APPENDIX, THE BOXES NEED NOT BE REUNITIZED SOLELY TO CONFORM TO THIS APPENDIX.
- H. THE UNITIZATION PROCEDURES DEPICTED HEREIN MAY ALSO BE USED FOR UNITIZING SHAPE CHARGES WHEN IDENTIFIED BY DIFFERENT NATIONAL STOCK NUMBERS (NSN) THAN WHAT IS SHOWN ON THE TITLE PAGE, PROVIDED THE BOX PACK DOES NOT VARY FROM WHAT IS DELINEATED HEREIN. THE EXPLOSIVE CLASSIFICATION OF OTHER ITEMS MAY BE DIFFERENT THAN WHAT IS SHOWN.
- J. POSITION THE THREE OUTBOARD BOXES OF THE BOTTOM LAYER ON THE 40" SIDES OF THE PALLET WITH THE TOPS DOWNWARD, AND THE THREE OUTBOARD BOXES OF THE TOP LAYER ON THE 40" SIDES OF THE PALLET WITH THE TOPS UPWARD.
- K. WHEN THE UNIT LOAD DEPICTED AT LEFT IS TO BE USED FOR UNITIZING MARINE CORPS AMMUNITION, ONE LAYER OF BOXES MUST BE OMITTED, TIEDOWN STRAP LENGTHS MUST BE DECREASED TO 14'-6", AND LOAD STRAP LENGTHS MUST BE DECREASED TO 15'-8". THIS WILL RESULT IN AN OVERALL UNIT HEIGHT OF 42", A GROSS UNIT WEIGHT OF 1,336 POUNDS, AND A UNIT CUBE OF 54.4 CUBIC FEET. ADDITIONALLY, THE UNIT LOAD MAY BE MODIFIED AS DESCRIBED WHEN BEING SHIPPED BY MILVAN OR COMMERCIAL INTERMODAL FREIGHT CONTAINER, CONVENTIONAL VAN TRAILER OR CONVENTIONAL OR HIGH-CAPACITY BOXCAR. THE DETERMINATION TO REDUCE THE LOAD BY A LAYER FOR TRANSPORTATION WILL BE MADE BY THE RESPONSIBLE COMMAND AND WILL BE BASED UPON ECONOMICS OF TRANSPORTATION AND HANDLING.

VERTICAL PIECE, 2" X 4"
X BOX HEIGHT (4 REQ'D).

END SUPPORT PIECE, 2" X 4" X
BOX WIDTH MINUS 6" (4 REQ'D).

SUPPORT PIECE, 2" X 4" (RIPPED TO FIT) X
BOX LENGTH (AS REQ'D). NAIL TO VERTICAL
PIECES W/2-10d NAILS AT EACH END. NOTE:
WHEN A UNIT HAS MORE THAN EIGHT BOXES
OMITTED, THE FILLER ASSEMBLY OR ASSEMBLIES
LOCATED IN OUTER STACK ON THE 40" SIDE
OR SIDES OF THE PALLET WILL REQUIRE A SUPPORT
PIECE.

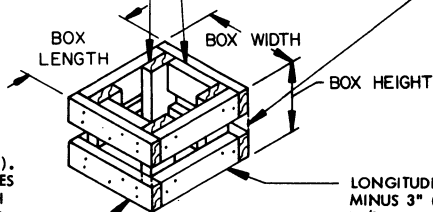

LATERAL PIECE, 2" X 4"
X BOX WIDTH (4 REQ'D).
NAIL TO VERTICAL PIECES
W/2-10d NAILS AT EACH
END AND NAIL TO END
SUPPORT PIECES W/2-10d NAILS.

LONGITUDINAL PIECE, 2" X 4" X BOX LENGTH
MINUS 3" (4 REQ'D). NAIL TO VERTICAL PIECES
W/2-10d NAILS AT EACH END.

FILLER ASSEMBLY

(FOR MINUS ONE BOX)