

APPENDIX 133

UNITIZATION PROCEDURES FOR BOXED AMMUNITION AND COMPONENTS ON 4-WAY ENTRY PALLETS

DYNAMITE, MILITARY, MI, PACKED 100 PER WOODEN
BOX, UNITIZED 24 BOXES PER 35" X 45 $\frac{1}{2}$ " PALLET;
APPROX BOX SIZE 20 $\frac{5}{8}$ " L X 15 $\frac{3}{16}$ " W X 9 $\frac{9}{16}$ " H

PALLET UNIT DATA						
ITEMS INCLUDED		HAZARD CLASSIFICATION ^①				WEIGHT
NSN	DODIC	DOT CLASS	CG CLASS	QD CLASS	COMP GROUP	(LBS)
1375-00-724-9613	M591	A	IX-B	1 1	D	2,879

NOTICE: THIS APPENDIX CANNOT STAND ALONE BUT MUST BE USED IN CONJUNCTION WITH THE BASIC UNITIZATION PROCEDURES DRAWING 19-48-4116-20PA1002.

① HAZARD CLASSIFICATION DATA CONTAINED IN THE ABOVE CHART IS FOR GUIDANCE AND INFORMATIONAL PURPOSES ONLY. VERIFICATION OF THE SPECIFIED DATA SHOULD BE MADE BY CONSULTING THE MOST RECENT JOINT HAZARD CLASSIFICATION SYSTEM LISTING OR OTHER APPROVED LISTING(S).

REVISIONS				DRAFTSMAN <i>RSH</i>	PROJ ENG <i>RSH</i>
				CHECKER <i>RSH</i>	LOG ENGRG OFFICE <i>RSH</i>
APPROVED U.S. ARMY ARMAMENT, MUNITIONS AND CHEMICAL COMMAND					
			<i>Keith Henton</i> DRSMC-LEP		<i>William J Ernst</i> DRSMC-TMO
APPROVED BY ORDER OF COMMANDING GENERAL, U.S. ARMY MATERIAL DEVELOPMENT AND READINESS COMMAND (DARCOM)					
<i>William J Ernst</i> U.S. ARMY DEFENSE AMMUNITION CENTER AND SCHOOL					
U. S. ARMY DARCOM DRAWING					
FEBRUARY 1984					
CLASS	DIVISION	DRAWING	FILE		
19	48	4116/133	20PA 1002		

DO NOT SCALE

GENERAL NOTES

- A. THIS APPENDIX CANNOT STAND ALONE BUT MUST BE USED IN CONJUNCTION WITH THE BASIC UNITIZATION PROCEDURES DRAWING 19-48-4116-20PA1002. TO PRODUCE AN APPROVED UNIT LOAD, ALL PERTINENT PROCEDURES, SPECIFICATIONS AND CRITERIA SET FORTH WITHIN THE BASIC DRAWING WILL APPLY TO THE PROCEDURES DELINEATED IN THIS APPENDIX. ANY EXCEPTIONS TO THE BASIC PROCEDURES ARE SPECIFIED IN THIS APPENDIX.
- B. DIMENSIONS, CUBE AND WEIGHT OF A PALLET UNIT WILL VARY SLIGHTLY DEPENDING UPON THE ACTUAL DIMENSIONS OF THE BOXES AND THE WEIGHT OF THE SPECIFIC ITEM BEING UNITIZED.
- C. THE LOAD STRAPS WILL BE THREADED THROUGH THE STRAP SLOTS OF THE PALLET. LOAD STRAPS WILL BE TENSIONED AND SEALED PRIOR TO APPLICATION OF TIEDOWN STRAPS.
- D. INSTALL EACH TIEDOWN STRAP TO PASS UNDER THE DECK BOARDS OF THE PALLET AND TO BE LOCATED AS SHOWN. TIEDOWN STRAPS WILL NOT BE APPLIED UNTIL THE LOAD STRAPS HAVE BEEN TENSIONED AND SEALED.
- E. THE FOLLOWING DARCOM DRAWINGS ARE APPLICABLE FOR OUT-LOADING AND STORAGE OF THE ITEMS COVERED BY THIS APPENDIX.
 - CARLOADING ----- DRAWING 19-48-4115-5PA1002
 - TRUCKLOADING ---- DRAWING 19-48-4117-11PA1003
 - STORAGE ----- DRAWING 19-48-4118-1-2-3-4-14-22PA1002
- F. FOR METHOD OF SECURING A STRAP CUTTER TO THE PALLET UNIT, SEE DARCOM DRAWING 19-48-4127-20P1000.
- G. IF ITEMS COVERED HEREIN ARE UNITIZED PRIOR TO ISSUANCE OF THIS APPENDIX, THE BOXES NEED NOT BE REUNITIZED SOLELY TO CONFORM TO THIS APPENDIX.
- H. THE UNITIZATION PROCEDURES DEPICTED HEREIN MAY ALSO BE USED FOR UNITIZING DYNAMITE, WHEN IDENTIFIED BY DIFFERENT NATIONAL STOCK NUMBERS (NSN) THAN WHAT IS SHOWN ON THE TITLE PAGE, PROVIDED THE BOX PACK DOES NOT VARY FROM WHAT IS DELINEATED HEREIN. THE EXPLOSIVE CLASSIFICATION OF OTHER ITEMS MAY BE DIFFERENT THAN WHAT IS SHOWN.
- J. WHEN THE UNIT LOAD DEPICTED AT LEFT IS TO BE USED FOR UNITIZING MARINE CORPS AMMUNITION, ONE LAYER OF BOXES MUST BE OMITTED, TIEDOWN STRAP LENGTHS MUST BE DECREASED TO 12'-9" AND LOAD STRAP LENGTHS MUST BE DECREASED TO 13'-6". THIS WILL RESULT IN AN OVER-ALL UNIT HEIGHT OF 34'-3/16", A GROSS UNIT WEIGHT OF 2,177 POUNDS, AND A UNIT CUBE OF 37.1 CUBIC FEET.
- K. THE 41-1/4" LENGTH DIMENSION OF THE UNIT LOAD DEPICTED AT LEFT IS AN EXCEPTION TO THE BASIC PROCEDURES. HOWEVER, THE EXCEPTION IS NECESSARY FOR THE AMMUNITION PACK COVERED BY THIS APPENDIX, TO MOST EFFECTIVELY GET AN ACCEPTABLE, COMPACT AND SOUND PALLET UNIT.

SEAL FOR 3/4" STRAPPING (5 REQD, 1 PER STRAP). CRIMP EACH SEAL WITH TWO PAIR OF NOTCHES.

TIEDOWN STRAP, 3/4" X .035" OR .031" X 14'-4" LONG STEEL STRAPPING (3 REQD). SEE GENERAL NOTE "D" AT RIGHT.

LOAD STRAP, 3/4" X .035" OR .031" X 15'-1" LONG STEEL STRAPPING (2 REQD). SEE GENERAL NOTE "C" AT RIGHT.

35" X 45-1/2" PALLET.

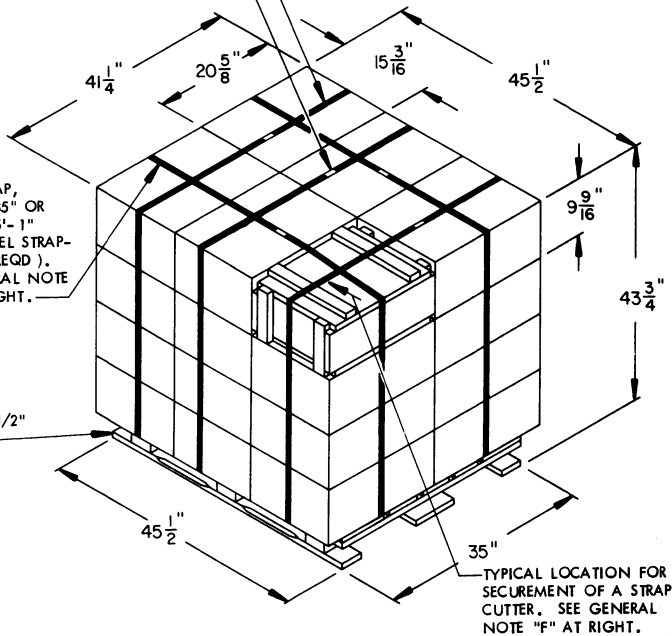

PALLET UNIT

SEE GENERAL NOTE "B" AT RIGHT.

24 BOXES OF DYNAMITE (100 PER BOX) @ 117 LBS -----	2,808 LBS (APPROX)
DUNNAGE -----	6 LBS
PALLET -----	65 LBS
TOTAL WEIGHT -----	2,879 LBS (APPROX)
CUBE -----	47.5 CU FT (APPROX)

BILL OF MATERIAL

PALLET, 35" X 45-1/2" -----	1 REQD	-----	65 LBS
STEEL STRAPPING, 3/4" -----	73.17" REQD	-----	5.22 LBS
SEAL FOR 3/4" STRAPPING -----	5 REQD	-----	NIL

VERTICAL PIECE, 2" X 4" X BOX HEIGHT MINUS 3/4" (4 REQD).
 TIE PIECE, 1" X 4" X BOX WIDTH (2 REQD). NAIL TO LONGITUDINAL PIECES W/2-6d NAILS AT EACH END AND TO LATERAL PIECE W/1-6d NAIL.

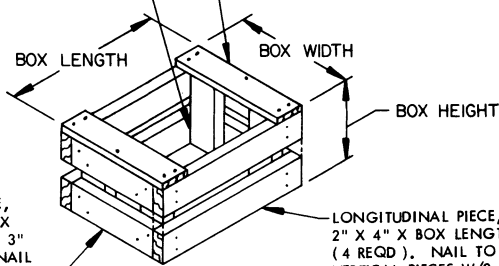

LATERAL PIECE, 2" X 4" X BOX WIDTH MINUS 3" (4 REQD). NAIL TO VERTICAL PIECES W/2-10d NAILS AT EACH END.

LONGITUDINAL PIECE, 2" X 4" X BOX LENGTH (4 REQD). NAIL TO VERTICAL PIECES W/2-10d NAILS AT EACH END.

FILLER ASSEMBLY
(FOR MINUS ONE BOX)