

APPENDIX 12B

UNITIZATION PROCEDURES FOR BOXED AMMUNITION AND COMPONENTS ON 4-WAY ENTRY PALLETS

CARTRIDGE, CALIBER .38, PACKED 1,800 PER
WOODEN BOX, UNITIZED 60 BOXES PER 40" X 48"
PALLET; APPROX BOX SIZE $14\frac{1}{4}"$ L X $10\frac{1}{8}"$ W X $7\frac{7}{8}"$ H

PALLET UNIT DATA						
ITEMS INCLUDED		HAZARD CLASSIFICATION				WEIGHT
NSN	DODIC	DOT CLASS	CG CLASS	QD CLASS	COMP GROUP	(LBS)
1305-00-344-2400	A409	C	I	1.4	S	3,931

NOTICE: THIS APPENDIX CANNOT STAND ALONE BUT MUST
BE USED IN CONJUNCTION WITH THE BASIC UNITIZATION
PROCEDURES DRAWING 19-48-4116-20PA1002.

REVISIONS											
			<table style="width: 100%; border-collapse: collapse;"> <tr> <td style="font-size: small;">DRAWN</td> <td style="font-size: small;">PROJ. ENG.</td> </tr> <tr> <td style="text-align: center;"><i>SP/7AK</i></td> <td style="text-align: center;"><i>R.B./NEW</i></td> </tr> <tr> <td style="font-size: small;">CHECKER</td> <td style="font-size: small;">LOG ENGR. OFFICE</td> </tr> <tr> <td style="text-align: center;"><i>GEG/18</i></td> <td style="text-align: center;"><i>John [Signature]</i></td> </tr> </table>	DRAWN	PROJ. ENG.	<i>SP/7AK</i>	<i>R.B./NEW</i>	CHECKER	LOG ENGR. OFFICE	<i>GEG/18</i>	<i>John [Signature]</i>
DRAWN	PROJ. ENG.										
<i>SP/7AK</i>	<i>R.B./NEW</i>										
CHECKER	LOG ENGR. OFFICE										
<i>GEG/18</i>	<i>John [Signature]</i>										
/	/	/	APPROVED, U. S. ARMY ARMAMENT MATERIEL READINESS COMMAND								
/	/	/	<table style="width: 100%; border-collapse: collapse;"> <tr> <td style="width: 50%; text-align: center;"><i>Lawrence Kuttler</i></td> <td style="width: 50%; text-align: center;"><i>David P. Feltner</i></td> </tr> <tr> <td style="font-size: x-small;">DR SAR - MAD</td> <td style="font-size: x-small;">DR SAR - THD</td> </tr> </table>	<i>Lawrence Kuttler</i>	<i>David P. Feltner</i>	DR SAR - MAD	DR SAR - THD				
<i>Lawrence Kuttler</i>	<i>David P. Feltner</i>										
DR SAR - MAD	DR SAR - THD										
/	/	/	APPROVED BY ORDER OF COMMANDING GENERAL, U. S. ARMY MATERIEL DEVELOPMENT AND READINESS COMMAND (DARCOM)								
/	/	/	<table style="width: 100%; border-collapse: collapse;"> <tr> <td style="text-align: center;"><i>John [Signature]</i></td> </tr> <tr> <td style="font-size: x-small;">U. S. ARMY DEFENSE AMMUNITION CENTER AND SCHOOL</td> </tr> </table>	<i>John [Signature]</i>	U. S. ARMY DEFENSE AMMUNITION CENTER AND SCHOOL						
<i>John [Signature]</i>											
U. S. ARMY DEFENSE AMMUNITION CENTER AND SCHOOL											
/	/	/	U. S. ARMY DARCOM DRAWING								
/	/	/	NOVEMBER 1979								
/	/	/	<table style="width: 100%; border-collapse: collapse;"> <tr> <td style="font-size: x-small;">CLASS</td> <td style="font-size: x-small;">DIVISION</td> <td style="font-size: x-small;">DRAWING</td> <td style="font-size: x-small;">FILE</td> </tr> <tr> <td style="text-align: center;">19</td> <td style="text-align: center;">48</td> <td style="text-align: center;">4116/12B</td> <td style="text-align: center;">20PA 1002</td> </tr> </table>	CLASS	DIVISION	DRAWING	FILE	19	48	4116/12B	20PA 1002
CLASS	DIVISION	DRAWING	FILE								
19	48	4116/12B	20PA 1002								

DO NOT SCALE

GENERAL NOTES

- A. THIS APPENDIX CANNOT STAND ALONE BUT MUST BE USED IN CONJUNCTION WITH THE BASIC UNITIZATION PROCEDURES DRAWING 19-48-4116-20PA1002. TO PRODUCE AN APPROVED UNIT LOAD, ALL PERTINENT PROCEDURES, SPECIFICATIONS AND CRITERIA SET FORTH WITHIN THE BASIC DRAWING WILL APPLY TO THE PROCEDURES DELINEATED IN THIS APPENDIX. ANY EXCEPTIONS TO THE BASIC PROCEDURES ARE SPECIFIED IN THIS APPENDIX.
- B. DIMENSIONS, CUBE AND WEIGHT OF A PALLET UNIT WILL VARY SLIGHTLY DEPENDING UPON THE ACTUAL DIMENSIONS OF THE BOXES AND THE WEIGHT OF THE SPECIFIC ITEM BEING UNITIZED.
- C. INSTALL EACH TIEDOWN STRAP TO PASS UNDER THE DECK/STRINGER BOARDS OF THE PALLET AND LOCATE AS SHOWN. TIEDOWN STRAPS WILL BE APPLIED BUT NOT TENSIONED UNTIL THE HORIZONTAL STRAPS HAVE BEEN INSTALLED AND TENSIONED.
- D. INSTALL EACH HORIZONTAL STRAP TO ENCIRCLE EACH LAYER OF BOXES ON THE PALLET. HORIZONTAL STRAPS MUST BE TENSIONED AND SEALED PRIOR TO TENSIONING OF TIEDOWN STRAPS.
- E. THE FOLLOWING DARCOM DRAWINGS ARE APPLICABLE FOR OUTLOADING AND STORAGE OF THE ITEMS COVERED BY THIS APPENDIX.

CARLOADING -----	DRAWING 19-48-4115-5PA1002
TRUCKLOADING -----	DRAWING 19-48-4117-11PA1003
STORAGE -----	DRAWING 19-48-4118-1-2-14-22PA1002
- F. FOR METHOD OF SECURING A STRAP CUTTER TO THE PALLET UNIT, SEE DARCOM DRAWING 19-48-4127-20P1000.
- G. IF ITEMS COVERED HEREIN ARE UNITIZED PRIOR TO ISSUANCE OF THIS APPENDIX, THE BOXES NEED NOT BE REUNITIZED SOLELY TO CONFORM TO THIS APPENDIX.
- H. THE UNITIZATION PROCEDURES DEPICTED HEREIN MAY ALSO BE USED FOR UNITIZING .38 CALIBER CARTRIDGES WHEN IDENTIFIED BY DIFFERENT NATIONAL STOCK NUMBERS (NSN) THAN WHAT IS SHOWN ON THE TITLE PAGE, PROVIDED THE BOX PACK DOES NOT VARY FROM WHAT IS DELINEATED HEREIN. THE EXPLOSIVE CLASSIFICATION OF OTHER ITEMS MAY BE DIFFERENT THAN WHAT IS SHOWN.

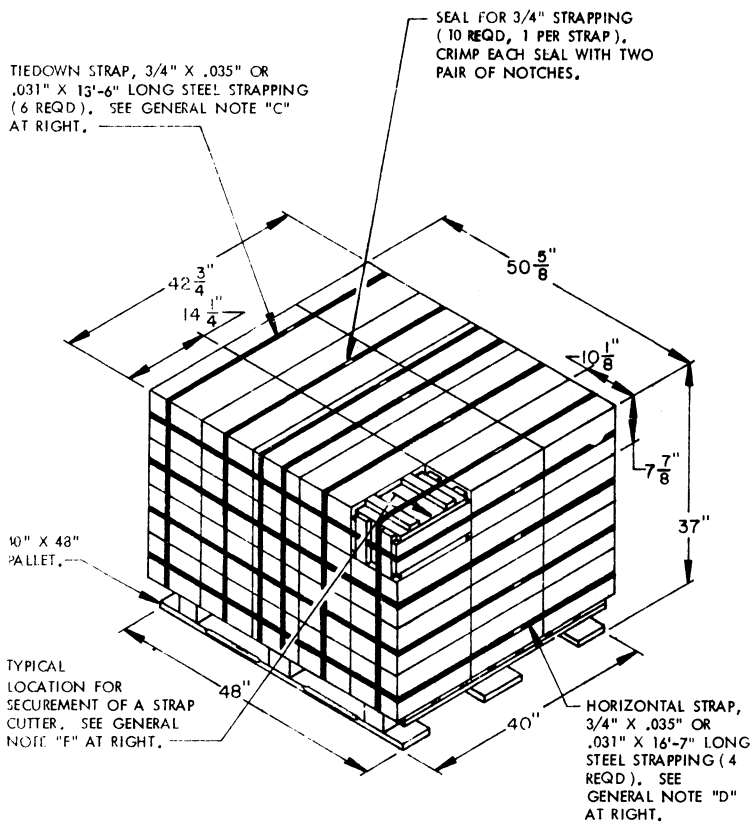

PALLET UNIT

SEE GENERAL NOTE "B" AT RIGHT.

60 BOXES OF .38 CALIBER CARTRIDGE (1,800 PER BOX) @ 64 LBS	----	3,840 LBS (APPROX)
DUNNAGE	----	11 LBS
PALLET	----	80 LBS
TOTAL WEIGHT	-----	3,931 LBS (APPROX)
CUBE	-----	46.3 CU FT (APPROX)

BILL OF MATERIAL

PALLET, 40" X 48"	-----	1 REQD	-----	80 LBS
STEEL STRAPPING, 3/4"	-----	147.33' REQD	-----	10.52 LBS
SEAL FOR 3/4" STRAPPING	-----	10 REQD	-----	NIL

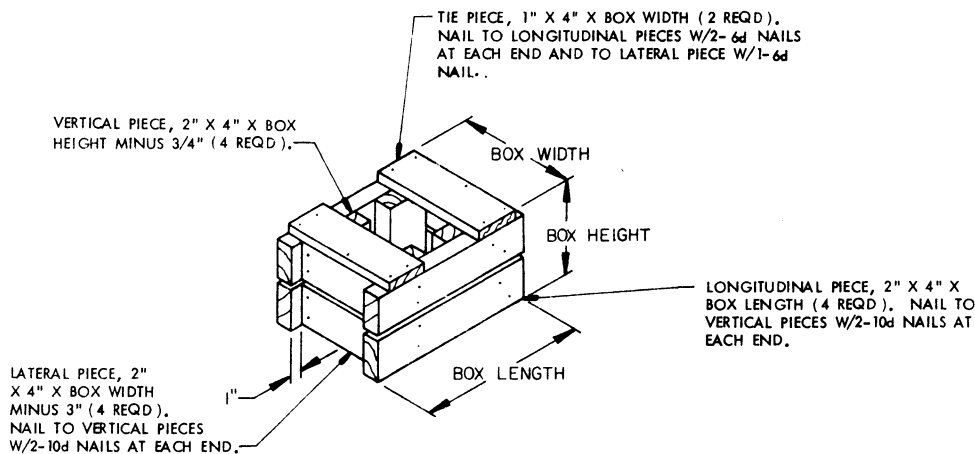

FILLER ASSEMBLY
(FOR MINUS ONE BOX)