

APPENDIX 128H

UNITIZATION PROCEDURES FOR BOXED AMMUNITION AND COMPONENTS ON 4-WAY ENTRY PALLETS

FIRING DEVICE, M122, PACKED 1 PER PLYWOOD BOX,
UNITIZED 8 BOXES PER 40" X 48" PALLET; APPROX
BOX SIZE 25½" L X 11½" W X 24½" H

PALLET UNIT DATA						
ITEMS INCLUDED		HAZARD CLASSIFICATION ①				WEIGHT (LBS)
NSN	DODIC	DOT CLASS	CG CLASS	QD CLASS	COMP GROUP	
1375- 01-021-0606	ML02	C	I	1.4	S	410

① HAZARD CLASSIFICATION DATA CONTAINED IN THE ABOVE CHART IS FOR GUIDANCE AND INFORMATIONAL PURPOSES ONLY. VERIFICATION OF THE SPECIFIED DATA SHOULD BE MADE BY CONSULTING THE MOST RECENT JOINT HAZARD CLASSIFICATION SYSTEM LISTING OR OTHER APPROVED LISTING(S).

NOTICE: THIS APPENDIX CANNOT STAND ALONE BUT MUST BE USED IN CONJUNCTION WITH THE BASIC UNITIZATION PROCEDURES DRAWING 19-48-4116-20PA1002.

REVISIONS																																																			
			<table border="1" style="width: 100%; border-collapse: collapse;"> <tr> <td style="font-size: small;">DESIGNER</td> <td style="font-size: small;">bh</td> <td style="font-size: small;">PROJ ENG</td> <td style="font-size: small;">AMC</td> </tr> <tr> <td style="font-size: small;">CHECKER</td> <td style="font-size: small;">AM</td> <td style="font-size: small;">LOG ISSUE OFFICER</td> <td style="font-size: small;">W. B. Smith</td> </tr> <tr> <td colspan="4" style="font-size: x-small;">APPROVED, U.S. ARMY ARMAMENT, MUNITIONS AND CEMICAL COMMAND</td> </tr> <tr> <td colspan="2" style="text-align: center;"><i>W. Martin</i></td> <td colspan="2" style="text-align: center;"><i>S. Baker</i></td> </tr> <tr> <td colspan="2" style="font-size: x-small;">SMCAR-EBK</td> <td colspan="2" style="font-size: x-small;">AMSC-TRD</td> </tr> <tr> <td colspan="4" style="font-size: x-small;">APPROVED BY ORDER OF COMMANDING GENERAL, U.S. ARMY MATERIAL COMMAND (AMC)</td> </tr> <tr> <td colspan="4" style="text-align: center;"><i>John L. Boyd</i></td> </tr> <tr> <td colspan="4" style="font-size: x-small;">U.S. ARMY DEFENSE AMMUNITION CENTER AND SCHOOL</td> </tr> <tr> <td colspan="4" style="text-align: center;">U.S. ARMY AMC DRAWING</td> </tr> <tr> <td colspan="4" style="text-align: center;">NOVEMBER 1984</td> </tr> <tr> <td style="font-size: x-small;">CLASS</td> <td style="font-size: x-small;">DIVISION</td> <td style="font-size: x-small;">DRAWING</td> <td style="font-size: x-small;">FILE</td> </tr> <tr> <td style="text-align: center;">19</td> <td style="text-align: center;">48</td> <td style="text-align: center;">4116/ 128H</td> <td style="text-align: center;">20PA 1002</td> </tr> </table>	DESIGNER	bh	PROJ ENG	AMC	CHECKER	AM	LOG ISSUE OFFICER	W. B. Smith	APPROVED, U.S. ARMY ARMAMENT, MUNITIONS AND CEMICAL COMMAND				<i>W. Martin</i>		<i>S. Baker</i>		SMCAR-EBK		AMSC-TRD		APPROVED BY ORDER OF COMMANDING GENERAL, U.S. ARMY MATERIAL COMMAND (AMC)				<i>John L. Boyd</i>				U.S. ARMY DEFENSE AMMUNITION CENTER AND SCHOOL				U.S. ARMY AMC DRAWING				NOVEMBER 1984				CLASS	DIVISION	DRAWING	FILE	19	48	4116/ 128H	20PA 1002
DESIGNER	bh	PROJ ENG	AMC																																																
CHECKER	AM	LOG ISSUE OFFICER	W. B. Smith																																																
APPROVED, U.S. ARMY ARMAMENT, MUNITIONS AND CEMICAL COMMAND																																																			
<i>W. Martin</i>		<i>S. Baker</i>																																																	
SMCAR-EBK		AMSC-TRD																																																	
APPROVED BY ORDER OF COMMANDING GENERAL, U.S. ARMY MATERIAL COMMAND (AMC)																																																			
<i>John L. Boyd</i>																																																			
U.S. ARMY DEFENSE AMMUNITION CENTER AND SCHOOL																																																			
U.S. ARMY AMC DRAWING																																																			
NOVEMBER 1984																																																			
CLASS	DIVISION	DRAWING	FILE																																																
19	48	4116/ 128H	20PA 1002																																																

DO NOT SCALE

GENERAL NOTES

- A. THIS APPENDIX CANNOT STAND ALONE BUT MUST BE USED IN CONJUNCTION WITH THE BASIC UNITIZATION PROCEDURES DRAWING 19-48-4116-20PA1002. TO PRODUCE AN APPROVED UNIT LOAD, ALL PERTINENT PROCEDURES, SPECIFICATIONS AND CRITERIA SET FORTH WITHIN THE BASIC DRAWING WILL APPLY TO THE PROCEDURES DELINEATED IN THIS APPENDIX. ANY EXCEPTIONS TO THE BASIC PROCEDURES ARE SPECIFIED IN THIS APPENDIX.
- B. DIMENSIONS, CUBE AND WEIGHT OF A PALLET UNIT WILL VARY SLIGHTLY DEPENDING UPON THE ACTUAL DIMENSIONS OF THE BOXES AND THE WEIGHT OF THE SPECIFIC ITEM BEING UNITIZED.
- C. INSTALL THE HORIZONTAL STRAP TO ENCIRCLE THE BOXES ON THE PALLET AS SHOWN. THE HORIZONTAL STRAP MUST BE TENSIONED AND SEALED PRIOR TO APPLICATION OF TIEDOWN STRAPS.
- D. INSTALL EACH TIEDOWN STRAP TO PASS UNDER THE TOP DECK BOARDS OF THE PALLET AND TO BE LOCATED AS SHOWN. TIEDOWN STRAPS WILL NOT BE APPLIED UNTIL THE HORIZONTAL STRAP HAS BEEN TENSIONED AND SEALED.
- E. THE FOLLOWING DARCOM DRAWINGS ARE APPLICABLE FOR OUTLOADING AND STORAGE OF THE ITEMS COVERED BY THIS APPENDIX.
- CARLOADING-----DRAWING 19-48-4115-5PA1002
TRUCKLOADING -----DRAWING 19-48-4117-11PA1003
STORAGE -----DRAWING 19-48-4118-1-2-3-4-14-22PA1002
- F. FOR METHOD OF SECURING A STRAP CUTTER TO THE PALLET UNIT, SEE DARCOM DRAWING 19-48-4127-20P1000.
- G. IF ITEMS COVERED HEREIN ARE UNITIZED PRIOR TO ISSUANCE OF THIS APPENDIX, THE BOXES NEED NOT BE REUNITIZED SOLELY TO CONFORM TO THIS APPENDIX.
- H. THE UNITIZATION PROCEDURES DEPICTED HEREIN MAY ALSO BE USED FOR UNITIZING FIRING DEVICES WHEN IDENTIFIED BY DIFFERENT NATIONAL STOCK NUMBERS (NSN) THAN WHAT IS SHOWN ON THE TITLE PAGE, PROVIDED THE BOX PACK DOES NOT VARY FROM WHAT IS DELINEATED HEREIN. THE EXPLOSIVE CLASSIFICATION OF OTHER ITEMS MAY BE DIFFERENT THAN WHAT IS SHOWN.
- J. THE 46" LENGTH DIMENSION IS AN EXCEPTION TO THE BASIC PROCEDURES, HOWEVER, THIS EXCEPTION IS NECESSARY FOR THE AMMUNITION PACK COVERED BY THIS APPENDIX, TO MOST EFFECTIVELY GET AN ACCEPTABLE, COMPACT, AND SOUND PALLET UNIT.

- K. IF THERE IS A NEED TO USE FILLER ASSEMBLIES AND AT LEAST TWO PALLET UNITS ARE BEING CONSTRUCTED, NOT MORE THAN 4 FILLERS WILL BE INSTALLED IN ANY ONE PALLET UNIT. ADDITIONAL FILLERS CAN BE PUT IN A SECOND PALLET UNIT AS REQUIRED WHEN THE QUANTITY OF 4 FILLERS IN THE FIRST REDUCED PALLET UNIT IS INSUFFICIENT TO SATISFY THE TOTAL REDUCTION NEEDED. USING TWO PALLET UNITS TO SATISFY THE PALLETIZATION CRITERIA APPLICABLE TO LESS-THAN-FULL PALLET UNITS IS AN EXCEPTION TO THE BASIC PROCEDURES, HOWEVER, THE EXCEPTION IS NECESSARY FOR THE AMMUNITION PACK COVERED BY THIS APPENDIX, TO MOST EFFECTIVELY GET AN ACCEPTABLE, COMPACT AND SOUND PALLET UNIT.

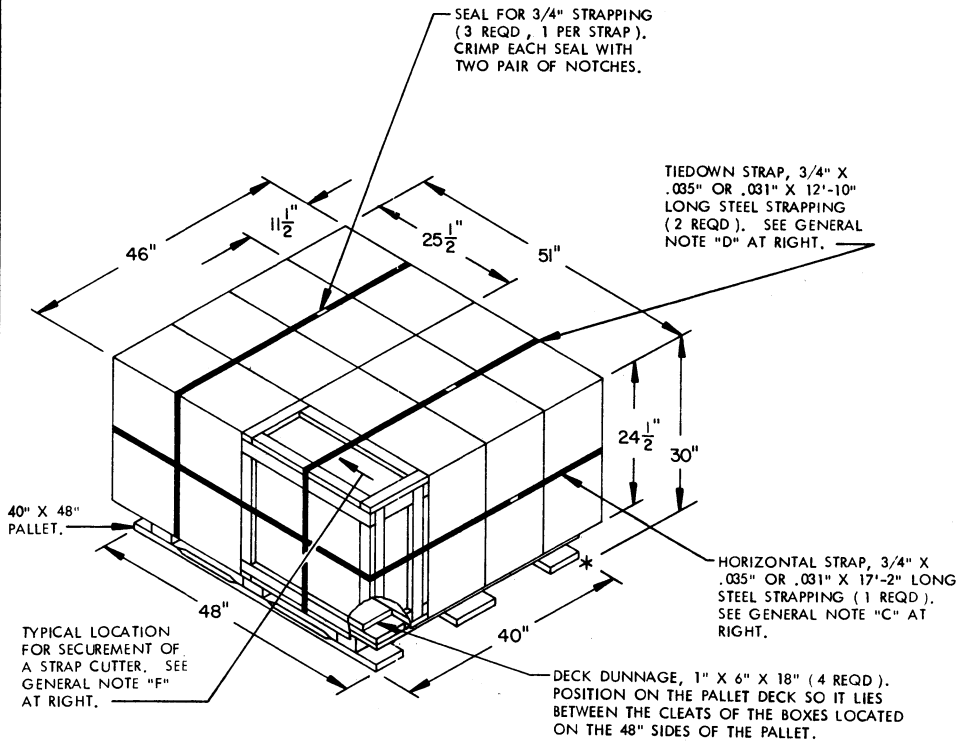

PALLET UNIT

SEE GENERAL NOTE "B" AT RIGHT.

8 BOXES OF FIRING DEVICE (1 PER BOX) @ 40 LBS-----	320 LBS (APPROX)
DUNNAGE-----	10 LBS
PALLET-----	80 LBS
TOTAL WEIGHT-----	410 LBS (APPROX)
CUBE-----	40.7 LBS (APPROX)

BILL OF MATERIAL

LUMBER	LINEAR FEET	BOARD FEET
1" X 6"	6	3
PALLET, 40" X 48" -----	1 REQD	80 LBS
STEEL STRAPPING, 3/4" -----	42.83' REQD	3.06 LBS
SEAL FOR 3/4" STRAPPING -----	3 REQD	NIL

TIE PIECE, 1" X 4" X BOX WIDTH (2 REQD.). NAIL TO LATERAL PIECES W/1-6d NAIL AT EACH END AND TO LONGITUDINAL PIECE W/3-6d NAILS.

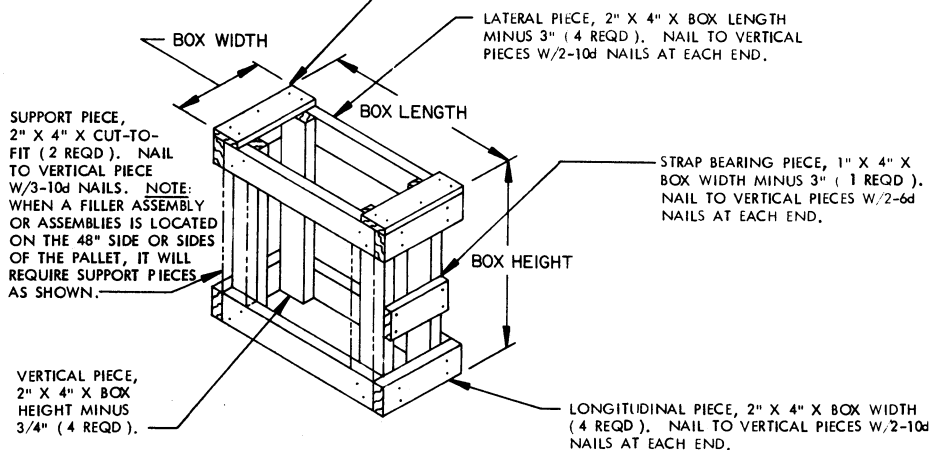

FILLER ASSEMBLY
(FOR MINUS ONE BOX)