

# APPENDIX 128A

## UNITIZATION PROCEDURES FOR BOXED AMMUNITION AND COMPONENTS ON 4-WAY ENTRY PALLETS

FIRING DEVICE, DEMOLITION, M3, PACKED 150 PER  
WOODEN BOX, UNITIZED 36 BOXES PER 35" X 45½"  
PALLET; APPROX BOX SIZE 15⅜" L X 11⅜" W X 10¾" H

PALLET UNIT DATA						
ITEMS INCLUDED		HAZARD CLASSIFICATION ①				WEIGHT (LBS)
NSN	DODIC	DOT CLASS	CG CLASS	QD CLASS	COMP GROUP	
1375-00-028-5188	M629	C	I	1.4	S	1,895

NOTICE: THIS APPENDIX CANNOT STAND ALONE BUT MUST  
BE USED IN CONJUNCTION WITH THE BASIC UNITIZATION  
PROCEDURES DRAWING 19-48-4116-20PA1002.

① HAZARD CLASSIFICATION DATA CONTAINED IN THE ABOVE CHART IS FOR GUIDANCE AND INFORMATIONAL PURPOSES ONLY. VERIFICATION OF THE SPECIFIED DATA SHOULD BE MADE BY CONSULTING THE MOST RECENT JOINT HAZARD CLASSIFICATION SYSTEM LISTING OR OTHER APPROVED LISTING(S).

**DO NOT SCALE**

REVISIONS				DRAWN <i>[Signature]</i>	PROJ ENG <i>[Signature]</i>
				CHECKER <i>[Signature]</i>	LOG ENGRG OFFICE <i>[Signature]</i>
				APPROVED, U. S. ARMY AMMUNITION SORTIONS AND CHEMICAL COMMAND <i>[Signature]</i>	
				DRSMC LEP	DRSMC TMD
				APPROVED BY ORDER OF COMMANDING GENERAL, U. S. ARMY MATERIEL DEVELOPMENT AND READINESS COMMAND (DARCOM) <i>[Signature]</i>	
				U. S. ARMY DEFENSE AMMUNITION CENTER AND SCHOOL	
				U. S. ARMY DARCOM DRAWING	
				OCTOBER 1983	
				CLASS	DIVISION
				19	48
				DRAWING	FILE
				4116/ 128A	20PA 1002

LOAD STRAP, 3/4" X .035" OR .031" X 16'-0" LONG STEEL STRAPPING (3 REQD). SEE GENERAL NOTE "C" AT RIGHT.

SPACER ASSEMBLY (1 REQD). SEE THE DETAIL BELOW. STAPLE TIEDOWN STRAPS TO SPACER ASSEMBLY AS SHOWN.

SEAL FOR 3/4" STRAPPING (6 REQD, 1 PER STRAP). CRIMP EACH SEAL WITH TWO PAIR OF NOTCHES.

TIEDOWN STRAP, 3/4" X .035" OR .031" X 14'-3" LONG STEEL STRAPPING (3 REQD). SEE GENERAL NOTE "D" AT RIGHT.

35" X 45-1/2" PALLET.

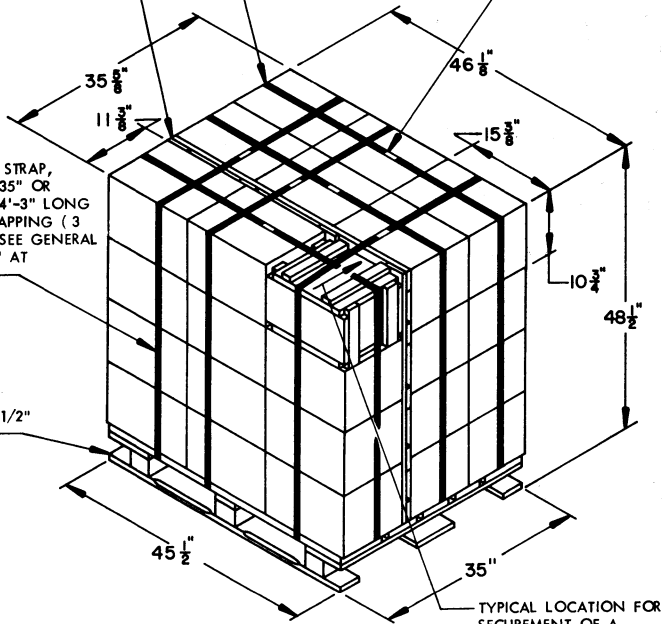

**PALLET UNIT**  
SEE GENERAL NOTE "B" AT RIGHT.

36 BOXES OF FIRING DEVICES (150 PER BOX) @ 50 LBS	-----	1,800 LBS (APPROX)
DUNNAGE	-----	30 LBS
PALLET	-----	65 LBS
<b>TOTAL WEIGHT</b>	-----	<b>1,895 LBS (APPROX)</b>
<b>CUBE</b>	-----	<b>46.1 CU FT (APPROX)</b>

**GENERAL NOTES**

- A. THIS APPENDIX CANNOT STAND ALONE BUT MUST BE USED IN CONJUNCTION WITH THE BASIC UNITIZATION PROCEDURES DRAWING 19-48-4116-20PA1002. TO PRODUCE AN APPROVED UNIT LOAD, ALL PERTINENT PROCEDURES, SPECIFICATIONS AND CRITERIA SET FORTH WITHIN THE BASIC DRAWING WILL APPLY TO THE PROCEDURES DELINEATED IN THIS APPENDIX. ANY EXCEPTIONS TO THE BASIC PROCEDURES ARE SPECIFIED IN THIS APPENDIX.
- B. DIMENSIONS, CUBE AND WEIGHT OF A PALLET UNIT WILL VARY SLIGHTLY DEPENDING UPON THE ACTUAL DIMENSIONS OF THE BOXES AND THE WEIGHT OF THE SPECIFIC ITEM BEING UNITIZED.
- C. THE LOAD STRAPS MAY BE THREADED THROUGH THE STRAP SLOTS OF A PALLET OR PRE-POSITIONED ON THE PALLET DECK PRIOR TO PLACING BOXES ON THE PALLET.
- D. INSTALL EACH TIEDOWN STRAP TO PASS UNDER THE TOP DECK BOARDS OF THE PALLET AND TO BE LOCATED AS SHOWN. TIEDOWN STRAPS WILL BE TENSIONED AND SEALED PRIOR TO LOAD STRAPS.
- E. THE FOLLOWING DARCOM DRAWINGS ARE APPLICABLE FOR OUTLOADING AND STORAGE OF THE ITEMS COVERED BY THIS APPENDIX.
 

CARLOADING -----	DRAWING 19-48-4115-5PA1002
TRUCKLOADING -----	DRAWING 19-48-4117-11PA1003
STORAGE -----	DRAWING 19-48-4118-1-2-3-4-14-22PA1002
- F. FOR METHOD OF SECURING A STRAP CUTTER TO THE PALLET UNIT, SEE DARCOM DRAWING 19-48-4127-20P1000.
- G. IF ITEMS COVERED HEREIN ARE UNITIZED PRIOR TO ISSUANCE OF THIS APPENDIX, THE BOXES NEED NOT BE REUNITIZED SOLELY TO CONFORM TO THIS APPENDIX.
- H. THE UNITIZATION PROCEDURES DEPICTED HEREIN MAY ALSO BE USED FOR UNITIZING FIRING DEVICES WHEN IDENTIFIED BY DIFFERENT NATIONAL STOCK NUMBERS (NSN) THAN WHAT IS SHOWN ON THE TITLE PAGE, PROVIDED THE BOX PACK DOES NOT VARY FROM WHAT IS DELINEATED HEREIN. THE EXPLOSIVE CLASSIFICATION OF OTHER ITEMS MAY BE DIFFERENT THAN WHAT IS SHOWN.
- J. WHEN THE UNIT LOAD DEPICTED AT LEFT IS TO BE USED FOR UNITIZING MARINE CORPS AMMUNITION, ONE LAYER OF BOXES MUST BE OMITTED, TIEDOWN STRAP LENGTHS MUST BE DECREASED TO 12'-5", LOAD STRAP LENGTHS MUST BE DECREASED TO 14'-2", AND THE SPACER ASSEMBLY MUST BE MODIFIED. SPACER ASSEMBLY MODIFICATIONS INCLUDE CHANGING VERTICAL PIECE LENGTH TO 32-1/4", ELIMINATING THE HORIZONTAL PIECES LOCATED AT 43" HEIGHT, AND LOCATING THE UPPER HORIZONTAL PIECES EVEN WITH THE TOP OF THE VERTICAL PIECES. THIS WILL RESULT IN AN OVERALL UNIT HEIGHT OF 37-3/4", A GROSS UNIT WEIGHT OF 1,439 POUNDS, AND A UNIT CUBE OF 35.9 CUBIC FEET. ADDITIONALLY, THE UNIT LOAD MAY BE MODIFIED AS DESCRIBED WHEN BEING SHIPPED BY MILVAN OR COMMERCIAL INTERMODAL FREIGHT CONTAINER, CONVENTIONAL VAN TRAILER OR CONVENTIONAL OR HIGH-CAPACITY BOXCAR. THE DETERMINATION TO REDUCE THE LOAD BY A LAYER FOR TRANSPORTATION WILL BE MADE BY THE RESPONSIBLE COMMAND AND WILL BE BASED UPON ECONOMICS OF TRANSPORTATION AND HANDLING.

BILL OF MATERIAL		
LUMBER	LINEAR FEET	BOARD FEET
1" X 4"	33.5	13.17
NAILS	NO. REQD	POUNDS
6d (2")	40	0.24
PALLET, 35" X 45-1/2"	1 REQD	65 LBS
STEEL STRAPPING, 3/4"	90.75' REQD	6.48 LBS
SEAL FOR 3/4" STRAPPING	6 REQD	NIL
STAPLE	3 REQD	NIL

TIE PIECE, 1" X 4" X BOX WIDTH (2 REQD). NAIL TO LONGITUDINAL PIECES W/2-6d NAILS AT EACH END AND TO LATERAL PIECES W/1-6d NAIL.

VERTICAL PIECE, 2" X 4" X BOX HEIGHT MINUS 3/4" (4 REQD).

LONGITUDINAL PIECE, 2" X 4" X BOX LENGTH (4 REQD). NAIL TO VERTICAL PIECES W/2-10d NAILS AT EACH END.

**FILLER ASSEMBLY**  
(FOR MINUS ONE BOX)

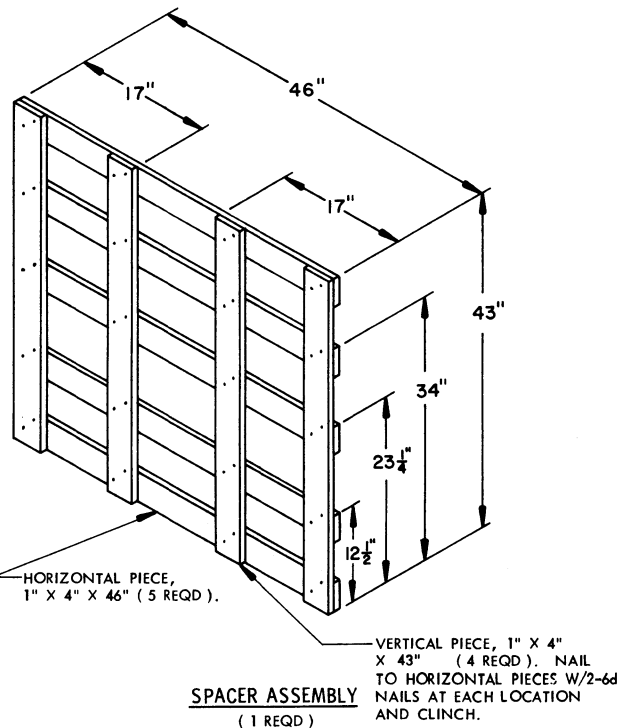
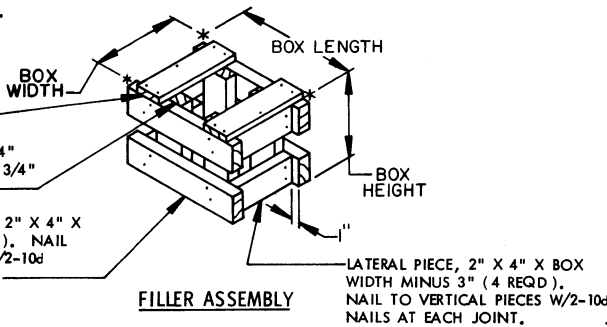

**SPACER ASSEMBLY**  
(1 REQD)