

# APPENDIX 127

## UNITIZATION PROCEDURES FOR BOXED AMMUNITION AND COMPONENTS ON 4-WAY ENTRY PALLETS

CORD, DETONATING, REINFORCED, DUMMY, PACKED  
6 SPOOLS PER WOODEN BOX, UNITIZED 12 BOXES  
PER 35" X 45-1/2" PALLET; APPROX BOX SIZE  
23-1/2" L X 13-1/2" W X 13-1/2" H

**NOTICE:** THIS APPENDIX CANNOT STAND ALONE BUT MUST BE USED IN CONJUNCTION WITH  
THE BASIC UNITIZATION PROCEDURES DRAWING 19-48-4116-20PA1002.

**DISTRIBUTION STATEMENT A.**

APPROVED FOR PUBLIC RELEASE;  
DISTRIBUTION IS UNLIMITED.

U. S. ARMY MATERIEL COMMAND DRAWING			
APPROVED, U. S. ARMY ARMAMENT, MUNITIONS AND CHEMICAL COMMAND  <i>David A. Piskard</i> <i>Trinity J. Lee</i> SMCAR-ESK                      AMSMC-TMJ	DRAFTSMAN	BETTY J. KUNDERT	
	ENGINEER	SANDRA M. SCHULTZ	
	SUPPLY ENGINEERING DIVISION	TRANSPORTATION ENGINEERING DIVISION	VALIDATION ENGINEERING DIVISION
	<i>T. J. Michels</i>	<i>W. J. Smith</i>	<i>REY D. S. JHC</i>
APPROVED BY ORDER OF COMMANDING GENERAL, U. S. ARMY MATERIEL COMMAND  <i>John L. Beyrout</i> U. S. ARMY DEFENSE AMMUNITION CENTER AND SCHOOL	LOGISTICS ENGINEERING OFFICE <i>William J. Ernst</i>		
	DECEMBER 1980		
	CLASS	DIVISION	DRAWING
REVISION NO. 1	AUGUST 1994	19	48
SEE THE REVISION LISTING ON PAGE 2		4116/ 127	20PA 1002

**DO NOT SCALE**

PALLET UNIT DATA				
ITEMS INCLUDED		HAZARD CLASS AND DIVISION ●		APPROX WEIGHT LBS
NSN	DODIC	OD CLASS	COMP GROUP	
1375-	M458			1,331

- HAZARD CLASSIFICATION DATA CONTAINED IN THE ABOVE CHART IS FOR GUIDANCE AND INFORMATIONAL PURPOSES ONLY. VERIFICATION OF THE SPECIFIED DATA SHOULD BE MADE BY CONSULTING THE MOST RECENT JOINT HAZARD CLASSIFICATION SYSTEM LISTING OR OTHER APPROVED LISTING(S).

#### REVISION

REVISION NO. 1, DATED AUGUST 1994, CONSISTS OF:

1. DELETING NSN FROM "PALLET UNIT DATA" CHART.

**GENERAL NOTES**

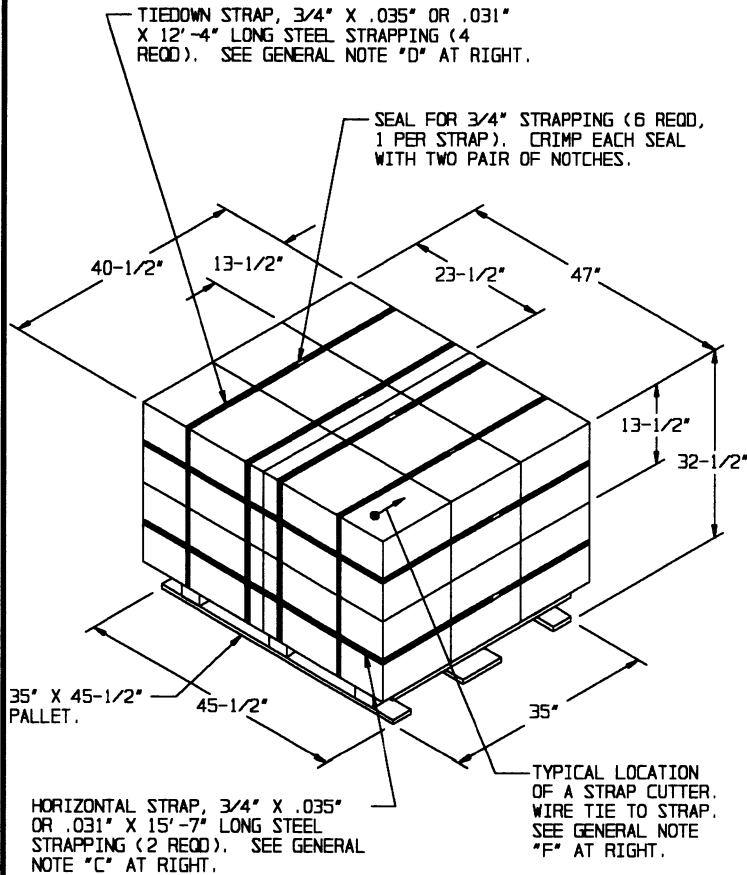

- A. THIS APPENDIX CANNOT STAND ALONE BUT MUST BE USED IN CONJUNCTION WITH THE BASIC UNITIZATION PROCEDURES DRAWING 19-48-4116-20PA1002. TO PRODUCE AN APPROVED UNIT LOAD, ALL PERTINENT PROCEDURES, SPECIFICATIONS AND CRITERIA SET FORTH WITHIN THE BASIC DRAWING WILL APPLY TO THE PROCEDURES DELINEATED IN THIS APPENDIX. ANY EXCEPTIONS TO THE BASIC PROCEDURES ARE SPECIFIED IN THIS APPENDIX.
- B. DIMENSIONS, CUBE AND WEIGHT OF A PALLET UNIT WILL VARY SLIGHTLY DEPENDING UPON THE ACTUAL DIMENSIONS OF THE BOXES AND THE WEIGHT OF THE SPECIFIC ITEM BEING UNITIZED.
- C. INSTALL EACH HORIZONTAL STRAP TO ENCIRCLE A LAYER OF BOXES ON THE PALLET. HORIZONTAL STRAPS MUST BE TENSIONED AND SEALED PRIOR TO THE APPLICATION OF TIEDOWN STRAPS.
- D. INSTALL EACH TIEDOWN STRAP TO PASS UNDER THE TOP DECK BOARDS OF THE PALLET AND TO BE LOCATED AS SHOWN. TIEDOWN STRAPS WILL NOT BE APPLIED UNTIL THE HORIZONTAL STRAPS HAVE BEEN TENSIONED AND SEALED.
- E. THE FOLLOWING AMC DRAWINGS ARE APPLICABLE FOR OUTLOADING AND STORAGE OF THE ITEMS COVERED BY THIS APPENDIX.

CARLOADING - - - - 19-48-4115-5PA1002  
 TRUCKLOADING - - - 19-48-4117-11PA1003  
 STORAGE - - - - - 19-48-4118-1-2-3-4-14-22PA1002  
 END OPENING ISO  
 CONTAINER - - - - 19-48-4153-15PA1002  
 MILVAN - - - - - 19-48-4166-15PA1003  
 SIDE OPENING ISO  
 CONTAINER - - - - 19-48-4267-15PA1009

- F. FOR METHOD OF SECURING A STRAP CUTTER TO THE PALLET UNIT, SEE AMC DRAWING 19-48-4127-20P1000.
- G. IF ITEMS COVERED HEREIN ARE UNITIZED PRIOR TO ISSUANCE OF THIS APPENDIX, THE BOXES NEED NOT BE REUNITIZED SOLELY TO CONFORM TO THIS APPENDIX.
- H. THE UNITIZATION PROCEDURES DEPICTED HEREIN MAY ALSO BE USED FOR UNITIZING DETONATING CORD WHEN IDENTIFIED BY DIFFERENT NATIONAL STOCK NUMBERS (NSN) THAN WHAT IS SHOWN ON PAGE 2, PROVIDED THE BOX PACK DOES NOT VARY FROM WHAT IS DELINEATED HEREIN. THE EXPLOSIVE CLASSIFICATION OF OTHER ITEMS MAY BE DIFFERENT THAN WHAT IS SHOWN.
- J. THE STYLE 1A PALLET DELINEATED IN THE DETAIL AT LEFT NEED NOT HAVE CHAMFERS OR STRAP SLOTS AS SPECIFIED WITHIN MILITARY SPECIFICATION MIL-P-15011 WHEN USED FOR THE UNITIZATION OF ITEMS COVERED BY THIS APPENDIX.

**PALLET UNIT**

SEE GENERAL NOTE 'B' AT RIGHT.

12 BOXES OF DETONATING CORD (6 PER BOX) AT 105 LBS	---	1,260 LBS (APPROX)
DUNNAGE	---	6 LBS
PALLET	---	65 LBS
<b>TOTAL WEIGHT</b>	---	<b>1,331 LBS (APPROX)</b>
<b>CUBE</b>	---	<b>35.8 CU FT (APPROX)</b>

**BILL OF MATERIAL**

PALLET, 35" X 45-1/2"	---	1 REQD	---	65 LBS
STEEL STRAPPING, 3/4"	---	80.50' REQD	---	5.75 LBS
SEAL FOR 3/4" STRAPPING	---	6 REQD	---	NIL

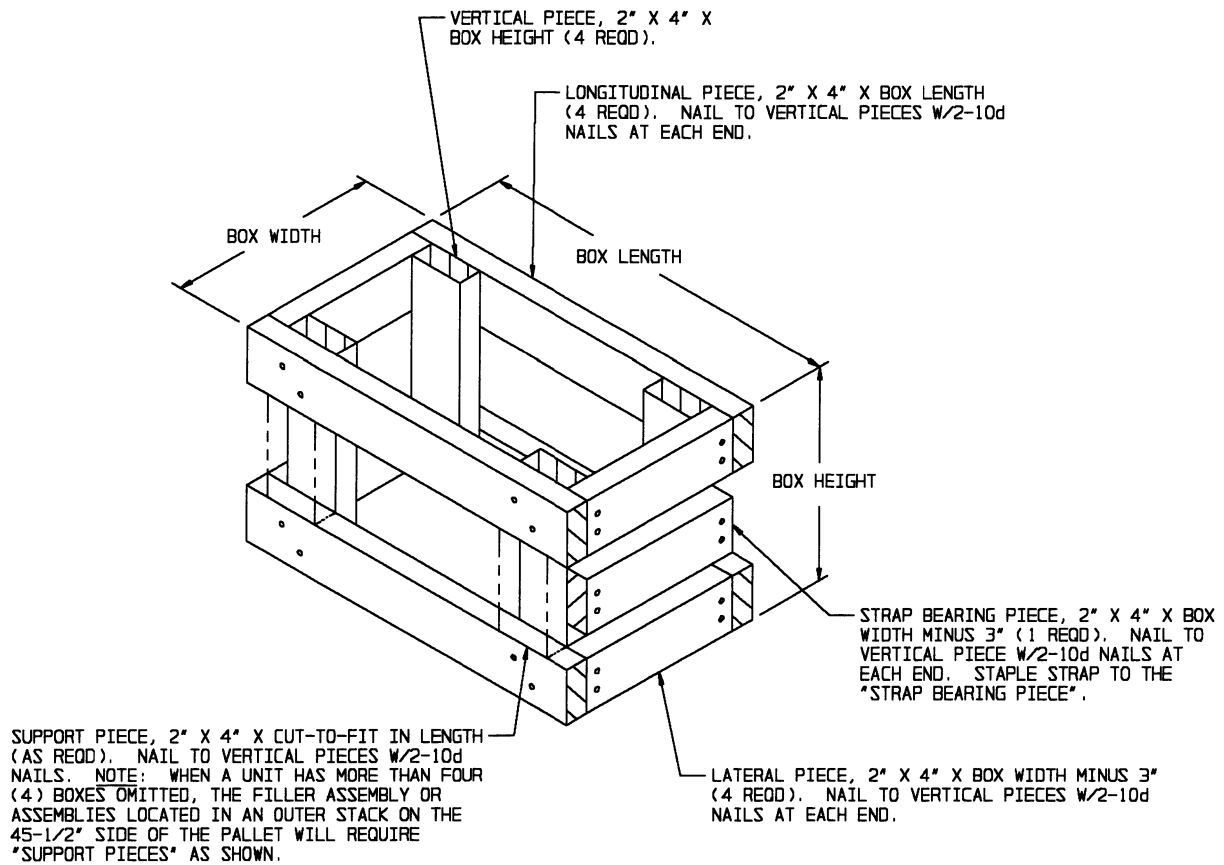

**FILLER ASSEMBLY**

(FOR MINUS ONE BOX)