

APPENDIX 126

UNITIZATION PROCEDURES FOR BOXED AMMUNITION AND COMPONENTS ON 4-WAY ENTRY PALLETS

DETONATOR, PERCUSSION, PACKED 200 PER
WOODEN BOX, UNITIZED 12 BOXES PER 42"
X 53" PALLET; APPROX BOX SIZE 21-1/2" L
X 17-11/16" W X 18-1/2" H

NOTICE: THIS APPENDIX CANNOT STAND ALONE BUT MUST BE USED IN CONJUNCTION WITH
THE BASIC UNITIZATION PROCEDURES DRAWING 19-48-4116-20PA1002.

DISTRIBUTION STATEMENT A.

APPROVED FOR PUBLIC RELEASE:
DISTRIBUTION IS UNLIMITED.

DO NOT SCALE

U. S. ARMY MATERIEL COMMAND DRAWING			
APPROVED, U. S. ARMY INDUSTRIAL OPERATIONS COMMAND <i>NLH</i> <i>David A. Patrick Timothy Jore</i> AMSTA-AR-ESK AMSIO-TMJ		DRAFTSMAN ENGINEER BETTY J. KLUNDERT SANDRA M. SCHULTZ	SUPPLY ENGINEERING DIVISION TRANSPORTATION ENGINEERING DIVISION VALIDATION ENGINEERING DIVISION
APPROVED BY ORDER OF COMMANDING GENERAL, U. S. ARMY MATERIEL COMMAND <i>Arthur Lodniadla</i> U. S. ARMY DEFENSE AMMUNITION CENTER		LOGISTICS ENGINEERING OFFICE <i>William F Ernst</i> DECEMBER 1980	
REVISION NO. 2	SEPTEMBER 1998	CLASS	DIVISION
SEE THE REVISION LISTING ON PAGE 2		DRAWING	FILE
		19	48
		4116/ 126	20PA 1002

PALLET UNIT DATA				
ITEMS INCLUDED		HAZARD CLASS AND DIVISION ●		APPROX WEIGHT LBS
NSN	DODIC	OD CLASS	COMP GROUP	
1375- 00-729-4375 00-729-4378	M448	1.4	B	841
	M450	1.4	B	841

HAZARD CLASSIFICATION DATA CONTAINED IN THE ABOVE CHART IS FOR GUIDANCE AND INFORMATIONAL PURPOSES ONLY. VERIFICATION OF THE SPECIFIED DATA SHOULD BE MADE BY CONSULTING THE MOST RECENT JOINT HAZARD CLASSIFICATION SYSTEM LISTING OR OTHER APPROVED LISTING(S).

REVISIONS

REVISION NO. 1, DATED APRIL 1995, CONSISTS OF:

1. CHANGING THE WEIGHT OF THE SHIPPING CONTAINER

REVISION NO. 2, DATED SEPTEMBER 1998, CONSISTS OF:

1. CHANGING THE BOX SIZE.
2. ADDING THE BOX DRAWING NUMBER TO GENERAL NOTES.
3. DELETING GENERAL NOTE RELATING TO THE STRAP CUTTER AND RE-LETTERING OTHER GENERAL NOTES.
4. DELETING ONE LAYER FROM THE PALLET UNIT.

GENERAL NOTES

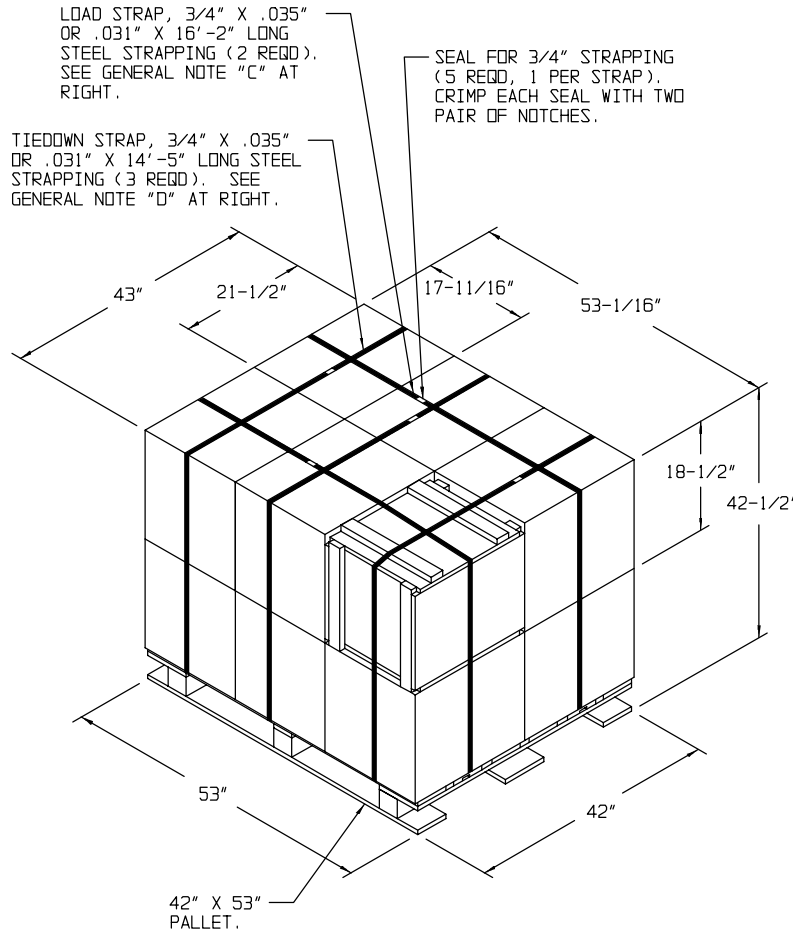

PALLET UNIT

SEE GENERAL NOTE "B" AT RIGHT.

12 BOXES OF DETONATOR (200 PER BOX) AT 62 LBS	---	744 LBS (APPROX)
DUNNAGE	-----	7 LBS
PALLET	-----	90 LBS

TOTAL WEIGHT	-----	841 LBS (APPROX)
CUBE	-----	56.1 CU FT (APPROX)

- A. THIS APPENDIX CANNOT STAND ALONE BUT MUST BE USED IN CONJUNCTION WITH THE BASIC UNITIZATION PROCEDURES DRAWING 19-48-4116-20PA1002. TO PRODUCE AN APPROVED UNIT LOAD, ALL PERTINENT PROCEDURES, SPECIFICATIONS AND CRITERIA SET FORTH WITHIN THE BASIC DRAWING WILL APPLY TO THE PROCEDURES DELINEATED IN THIS APPENDIX. ANY EXCEPTIONS TO THE BASIC PROCEDURES ARE SPECIFIED IN THIS APPENDIX.
- B. DIMENSIONS, CUBE AND WEIGHT OF A PALLET UNIT WILL VARY SLIGHTLY DEPENDING UPON THE ACTUAL DIMENSIONS OF THE BOXES AND THE WEIGHT OF THE SPECIFIC ITEM BEING UNITIZED.
- C. THE LOAD STRAPS MAY BE THREADED THROUGH THE STRAP SLOTS OF A PALLET OR PRE-POSITIONED ON THE PALLET DECK PRIOR TO PLACING BOXES ON THE PALLET. LOAD STRAPS MUST BE TENSIONED AND SEALED PRIOR TO APPLICATION OF TIEDOWN STRAPS.
- D. INSTALL EACH TIEDOWN STRAP TO PASS UNDER THE TOP DECK BOARDS OF THE PALLET AND TO BE LOCATED AS SHOWN. TIEDOWN STRAPS WILL NOT BE APPLIED UNTIL LOAD STRAPS HAVE BEEN TENSIONED AND SEALED.
- E. THE FOLLOWING AMC DRAWINGS ARE APPLICABLE FOR OUTLOADING AND STORAGE OF THE ITEMS COVERED BY THIS APPENDIX.
 - CARLOADING - - - - 19-48-4115-5PA1002
 - TRUCKLOADING - - - - 19-48-4117-11PA1003
 - STORAGE - - - - 19-48-4118-1-2-3-4-14-22PA1002
 - END OPENING ISD
 - CONTAINER - - - - 19-48-4153-15PA1002
 - MILVAN - - - - 19-48-4166-15PA1003
 - SIDE OPENING ISD
 - CONTAINER - - - - 19-48-4267-15PA1009
- F. IF ITEMS COVERED HEREIN ARE UNITIZED PRIOR TO ISSUANCE OF THIS APPENDIX, THE BOXES NEED NOT BE REUNITIZED SOLELY TO CONFORM TO THIS APPENDIX.
- G. THE UNITIZATION PROCEDURES DEPICTED HEREIN MAY ALSO BE USED FOR UNITIZING DETONATORS WHEN IDENTIFIED BY DIFFERENT NATIONAL STOCK NUMBERS (NSN) THAN WHAT IS SHOWN ON PAGE 2, PROVIDED THE BOX PACK DOES NOT VARY FROM WHAT IS DELINEATED HEREIN. THE EXPLOSIVE CLASSIFICATION OF OTHER ITEMS MAY BE DIFFERENT THAN WHAT IS SHOWN.
- H. THE STYLE 1B PALLET DELINEATED IN THE DETAIL AT LEFT NEED NOT HAVE CHAMFERS OR STRAP SLOTS AS SPECIFIED WITHIN MILITARY SPECIFICATION MIL-P-15011 WHEN USED FOR THE UNITIZATION OF ITEMS COVERED BY THIS APPENDIX.
- J. FOR DETAILS OF THE MIL-B-2427 WOODEN BOX SEE DRAWING 8825213.

BILL OF MATERIAL

PALLET, 42" X 53"	-----	1 REQD	-----	90 LBS
STEEL STRAPPING, 3/4"	-----	75.58' REQD	-----	6.75 LBS
SEAL FOR 3/4" STRAPPING	-----	5 REQD	-----	NIL

TIE PIECE, 1" X 4" X BOX WIDTH (2 REQD).
 NAIL TO LONGITUDINAL PIECES W/2-6d
 NAILS AT EACH END AND TO LATERAL
 PIECE W/1-6d NAIL.

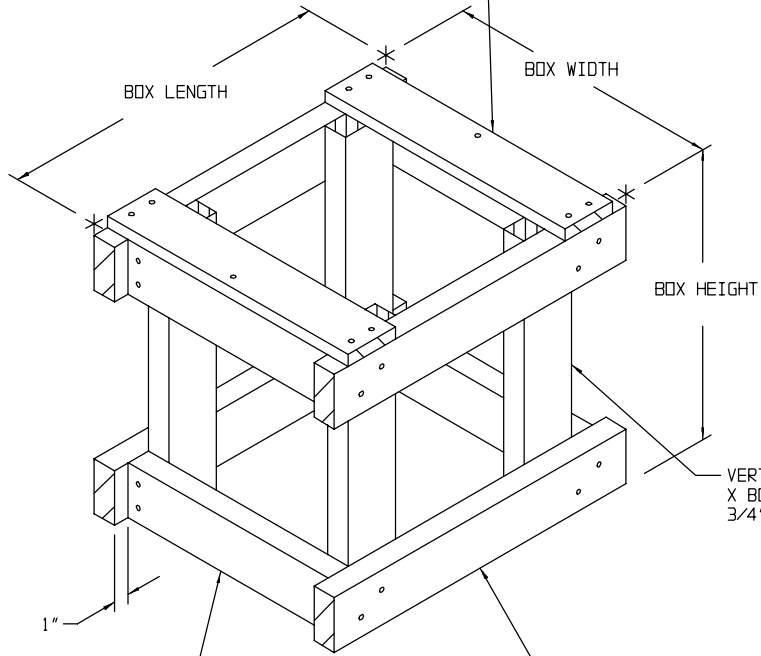

VERTICAL PIECE, 2" X 4"
 X BOX HEIGHT MINUS
 3/4" (4 REQD).

LATERAL PIECE, 2" X 4" X BOX WIDTH
 MINUS 3" (4 REQD). NAIL TO VERTICAL
 PIECES W/2-10d NAILS AT EACH END.

LONGITUDINAL PIECE, 2" X 4"
 X BOX LENGTH (4 REQD).
 NAIL TO VERTICAL PIECES
 W/2-10d NAILS AT EACH END.

FILLER ASSEMBLY

(FOR MINUS ONE BOX)