

APPENDIX 125B

UNITIZATION PROCEDURES FOR BOXED AMMUNITION AND COMPO- NENTS ON 4-WAY ENTRY PALLETS

**DEMOLITION KIT, BANGALORE TORPEDO, 2.5 FT,
M1A3, PACKED ONE PER WOODEN BOX, UNITIZED
20 BOXES PER 35" X 45-1/2" PALLET; APPROX BOX
SIZE 35-3/4" L X 13-1/8" W X 7" H**

**NOTICE: THIS APPENDIX CANNOT STAND ALONE BUT MUST BE USED IN CONJUNCTION WITH THE BASIC UNITIZATION
PROCEDURES DRAWING 19-48-4116-20PA1002.**

DISTRIBUTION STATEMENT A:

**APPROVED FOR PUBLIC RELEASE
DISTRIBUTION IS UNLIMITED.**

U.S. ARMY MATERIEL COMMAND DRAWING

<p>APPROVED, U.S. ARMY RESEARCH, DEVELOPMENT AND ENGINEERING COMMAND</p> <p>REHMSTEDT.MA RK.J.1230548400</p> <p style="font-size: small;">Digitally signed by REHMSTEDT.MARK.J.1230548400 DN: cn=US, o=U.S. Government, ou=DoD, ou=PKI, ou=USA, c=US, email=REHMSTEDT.MARK.J.1230548400 Date: 2013.12.31 12:16:00 -06'00'</p> <p style="text-align: right;">RDAR-EIL-TP</p>	<p>CAUTION: VERIFY PRIOR TO USE AT WWW.DAC.ARMY.MIL THAT THIS IS THE MOST CURRENT VERSION OF THIS DOCUMENT. THIS IS PAGE 1 OF 4.</p>		<p style="font-size: 2em; font-weight: bold;">APRIL 2005</p>						
<p>APPROVED, U.S. ARMY JOINT MUNITIONS COMMAND</p> <p>CASILLAS.GILBE RT.J.1230393644</p> <p style="font-size: small;">Digitally signed by CASILLAS.GILBERT.J.1230393644 DN: cn=US, o=U.S. Government, ou=DoD, ou=PKI, ou=USA, c=US, email=CASILLAS.GILBERT.J.1230393644 Date: 2014.01.08 12:55:00 -06'00'</p> <p style="text-align: right;">AMSJM-LIT</p>	<p>DO NOT SCALE</p>	<p>ENGINEER OR TECHNICIAN</p>	<p>BASIC REV.</p>	<p>LAURA A. FIEFFER SPENCER HOVEY</p>	<p>REVISION NO. 1</p>	<p>JANUARY 2014</p>			
<p>APPROVED BY ORDER OF COMMANDING GENERAL, U.S. ARMY MATERIEL COMMAND</p> <p>SHIMP.UPTON .R.1231257183</p> <p style="font-size: small;">Digitally signed by SHIMP.UPTON.R.1231257183 DN: cn=US, o=U.S. Government, ou=DoD, ou=PKI, ou=USA, c=US, email=SHIMP.UPTON.R.1231257183 Date: 2014.01.13 11:05:58 -06'00'</p> <p style="text-align: center;">U.S. ARMY DEFENSE AMMUNITION CENTER</p>	<p>TRANSPORTATION ENGINEERING DIVISION</p>	<p>FIEFFER.LAUR A.A.1230375727</p> <p style="font-size: x-small;">Digitally signed by FIEFFER.LAURA.A.1230375727 DN: cn=US, o=U.S. Government, ou=DoD, ou=PKI, ou=USA, c=US, email=FIEFFER.LAURA.A.1230375727 Date: 2012.04.25 07:49:18 -05'00'</p>	<p>VALIDATION ENGINEERING DIVISION</p>	<p>BARICKMAN. PHILIP.W.123 0202202</p> <p style="font-size: x-small;">Digitally signed by BARICKMAN.PHILIP.W.1230202202 DN: cn=US, o=U.S. Government, ou=DoD, ou=PKI, ou=USA, c=US, email=BARICKMAN.PHILIP.W.1230202202 Date: 2012.04.25 08:06:16 -05'00'</p>	<p>TESTED</p>	<p>CLASS</p>	<p>DIVISION</p>	<p>DRAWING</p>	<p>FILE</p>
	<p>ENGINEERING DIRECTORATE</p>	<p>BEAVER.JERRY .W.1230949952</p> <p style="font-size: x-small;">Digitally signed by BEAVER.JERRY.W.1230949952 DN: cn=US, o=U.S. Government, ou=DoD, ou=PKI, ou=USA, c=US, email=BEAVER.JERRY.W.1230949952 Date: 2012.04.27 07:14:45 -05'00'</p>		<p>19</p>	<p>48</p>	<p>4116/ 125B</p>	<p>20PA1002</p>	<p>SEE THE REVISION LISTING ON PAGE 2</p>	

PALLET UNIT DATA				
ITEMS INCLUDED		*HAZARD CLASS AND DIVISION	*COMPATI-BILITY GROUP	APPROX WEIGHT (LBS)
NSN	DODIC			
1375-01-528-7226	MP03	1. 1	D	1, 873

*HAZARD CLASSIFICATION DATA CONTAINED IN THE ABOVE CHART IS FOR GUIDANCE AND INFORMATIONAL PURPOSES ONLY. VERIFICATION OF THE SPECIFIED DATA SHOULD BE MADE BY CONSULTING THE MOST RECENT JOINT HAZARD CLASSIFICATION SYSTEM LISTING OR OTHER APPROVED LISTING(S).

REVISION

REVISION NO. 1, DATED JANUARY 2014, CONSISTS OF:

1. CHANGING DRAWING TITLE FROM 8 PER BOX TO 1 KIT PER BOX AND ADDING M1A3 TO NOMENCLATURE.
2. ADDING A REFERENCE OF .029" THICK STRAPPING TO TIEDOWN AND LOAD STRAPS.
3. CHANGING DRAWING REFERENCE IN NOTE "J" TO ARDEC DRAWING 13010551.

GENERAL NOTES

- A. THIS APPENDIX CANNOT STAND ALONE BUT MUST BE USED IN CONJUNCTION WITH THE BASIC UNITIZATION PROCEDURES DRAWING 19-48-4116-20PA1002. TO PRODUCE AN APPROVED UNIT LOAD, ALL PERTINENT PROCEDURES, SPECIFICATIONS AND CRITERIA SET FORTH WITHIN THE BASIC DRAWING WILL APPLY TO THE PROCEDURES DELINEATED IN THIS APPENDIX. ANY EXCEPTIONS TO THE BASIC PROCEDURES ARE SPECIFIED IN THIS APPENDIX.
- B. DIMENSIONS, CUBE AND WEIGHT OF A PALLET UNIT WILL VARY SLIGHTLY DEPENDING UPON THE ACTUAL DIMENSIONS OF THE BOXES AND THE WEIGHT OF THE SPECIFIC ITEM BEING UNITIZED.
- C. THE LOAD STRAPS MAY BE THREADED THROUGH THE STRAP SLOTS OF A PALLET OR PRE-POSITIONED ON THE PALLET DECK PRIOR TO PLACING THE BOXES ON THE PALLET. LOAD STRAPS MUST BE TENSIONED AND SEALED PRIOR TO APPLICATION OF TIEDOWN STRAPS.
- D. INSTALL EACH TIEDOWN STRAP TO PASS UNDER THE DECK/STRINGER BOARDS OF THE PALLET AND TO BE LOCATED AS SHOWN. TIEDOWN STRAPS WILL NOT BE APPLIED UNTIL THE LOAD STRAPS HAVE BEEN TENSIONED AND SEALED.
- E. THE FOLLOWING AMC DRAWINGS ARE APPLICABLE FOR OUTLOADING AND STORAGE OF THE ITEMS COVERED BY THIS APPENDIX.

CARLOADING	- - - -	19-48-4115-5PA1002
TRUCKLOADING	- - - -	19-48-4117-11PA1003
STORAGE	- - - -	19-48-4118-1-2-3-4-14-22PA1002
END OPENING ISO CONTAINER	- - - -	19-48-4153-15PA1002
MILVAN	- - - -	19-48-4166-15PA1003
SIDE OPENING ISO CONTAINER	- - - -	19-48-4267-15PA1009
- F. IF ITEMS COVERED HEREIN ARE UNITIZED PRIOR TO ISSUANCE OF THIS REVISION TO THIS APPENDIX, THE BOXES NEED NOT BE REUNITIZED SOLELY TO CONFORM TO THIS REVISION.
- G. THE UNITIZATION PROCEDURES DEPICTED HEREIN MAY ALSO BE USED FOR UNITIZING BANGALORE TORPEDO DEMOLITION KITS WHEN IDENTIFIED BY DIFFERENT NATIONAL STOCK NUMBERS (NSN) THAN WHAT IS SHOWN ON PAGE 2, PROVIDED THE BOX PACK DOES NOT VARY FROM WHAT IS DELINEATED HEREIN. THE EXPLOSIVE CLASSIFICATION OF OTHER ITEMS MAY BE DIFFERENT THAN WHAT IS SHOWN.
- H. THE STYLE 1A PALLET DELINEATED IN THE DETAIL AT LEFT NEED NOT HAVE CHAMFERS OR STRAP SLOTS AS SPECIFIED WITHIN MILITARY SPECIFICATION MIL-DTL-15011 WHEN USED FOR THE UNITIZATION OF ITEMS COVERED BY THIS APPENDIX.
- J. FOR DETAILS OF THE MIL-DTL-2427 WOODEN BOX SEE ARDEC DRAWING 13010551.
- K. THE 52-1/2" WIDTH DIMENSION IS AN EXCEPTION TO THE BASIC PROCEDURES. HOWEVER, THE EXCEPTION IS NECESSARY FOR THE AMMUNITION PACK COVERED BY THIS APPENDIX TO MOST EFFECTIVELY GET AN ACCEPTABLE, COMPACT AND SOUND PALLET UNIT.

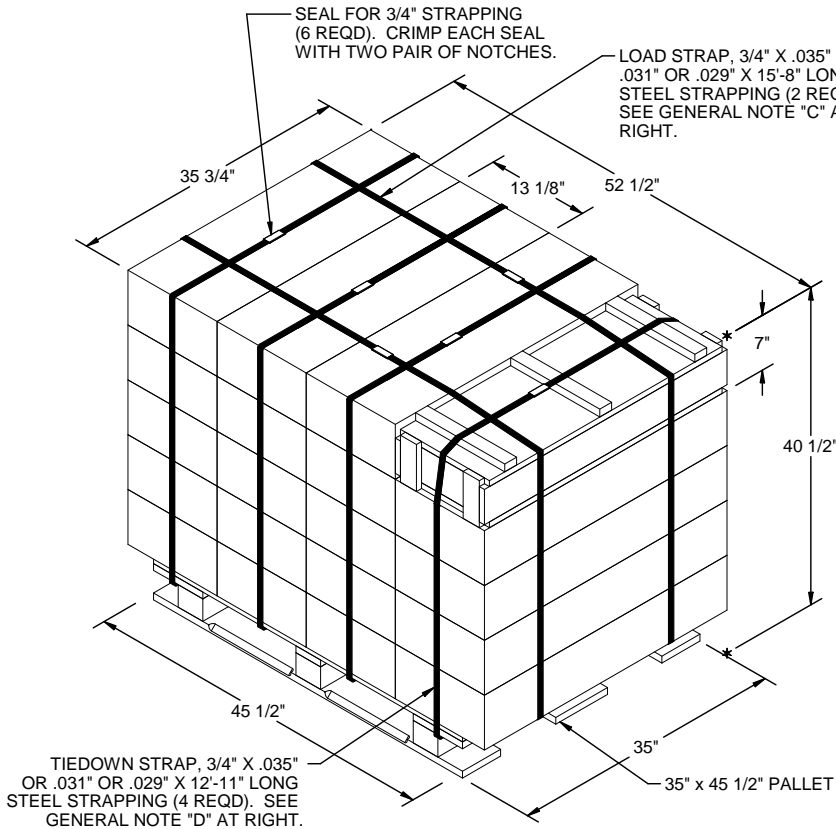

PALLET UNIT
SEE GENERAL NOTE "B" AT RIGHT.

20 BOXES OF DEMO KITS (1 PER BOX) @ 90 LBS	- - - - -	1,800 LBS (APPROX)
DUNNAGE	- - - - -	8 LBS
PALLET	- - - - -	65 LBS
TOTAL WEIGHT		1,873 LBS (APPROX)
CUBE		44.0 CU FT (APPROX)

BILL OF MATERIAL		
PALLET, 35" X 45-1/2"	- - - - 1 REQD	65 LBS
STEEL STRAPPING, 3/4"	- 83.00' REQD	7.42 LBS
SEAL FOR 3/4" STRAPPING	- - - 6 REQD	NIL

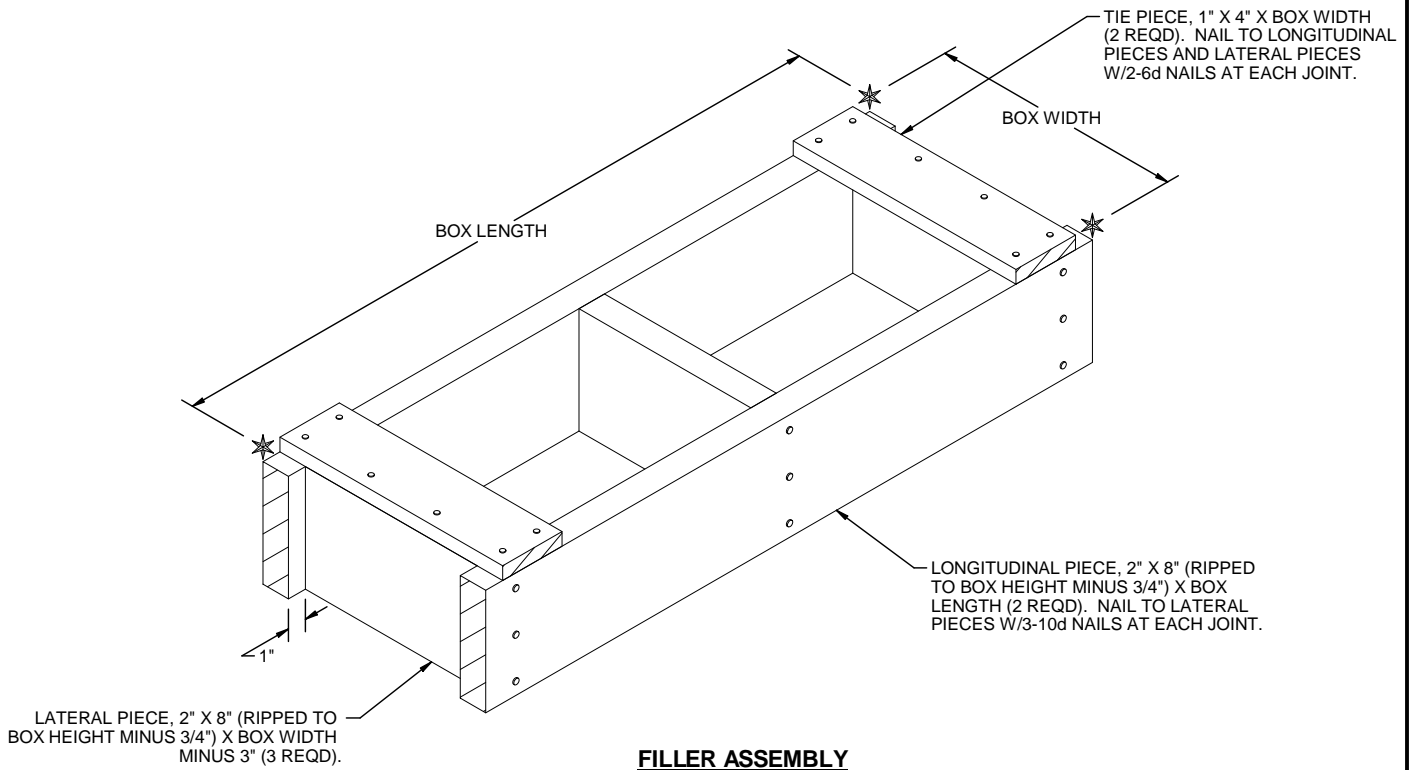

FILLER ASSEMBLY
 (FOR MINUS ONE BOX)