

APPENDIX 124

UNITIZATION PROCEDURES FOR BOXED AMMUNITION AND COMPONENTS ON 4-WAY ENTRY PALLETS

DETONATOR KIT, CONCUSSION, MI, PACKED 50 PER
WOODEN BOX, UNITIZED 16 BOXES PER 35"X45 1/2"
PALLET; APPROX BOX SIZE 20 1/2" L X 18 7/8" W X 11" H

PALLET UNIT DATA						
ITEMS INCLUDED		HAZARD CLASSIFICATION ①				WEIGHT
NSN	DODIC	DOT CLASS	CG CLASS	QD CLASS	COMP GROUP	(LBS)
1375-00-028-5173	M540	C	III	(04) 1.2	B	1,054

NOTICE: THIS APPENDIX CANNOT STAND ALONE BUT MUST BE USED IN CONJUNCTION WITH THE BASIC UNITIZATION PROCEDURES DRAWING 19-48-4116-20PA1002.

① HAZARD CLASSIFICATION DATA CONTAINED IN THE ABOVE CHART IS FOR GUIDANCE AND INFORMATIONAL PURPOSES ONLY. VERIFICATION OF THE SPECIFIED DATA SHOULD BE MADE BY CONSULTING THE MOST RECENT JOINT HAZARD CLASSIFICATION SYSTEM LISTING OR OTHER APPROVED LISTING(S).

DO NOT SCALE

REVISIONS				DRAFTSMAN <i>[Signature]</i>	PROJ ENG <i>[Signature]</i>
				CHECKER <i>[Signature]</i>	LOG. ENGR. OFFICE <i>[Signature]</i>
				APPROVED, U. S. ARMY ARMAMENT, MUNITIONS AND CHEMICAL COMMAND	
				<i>[Signature]</i>	<i>[Signature]</i>
				DRMCG - LEP	DRMCG - TMD
				APPROVED BY ORDER OF COMMANDING GENERAL, U. S. ARMY MATERIAL DEVELOPMENT AND READINESS COMMAND (DARCOM)	
				<i>[Signature]</i> U. S. ARMY DEFENSE AMMUNITION CENTER AND SCHOOL	
				U. S. ARMY DARCOM DRAWING	
				NOVEMBER 1983	
				CLASS	DIVISION
				DRAWING	FILE
				19	48
				4116/124	20PA 1002

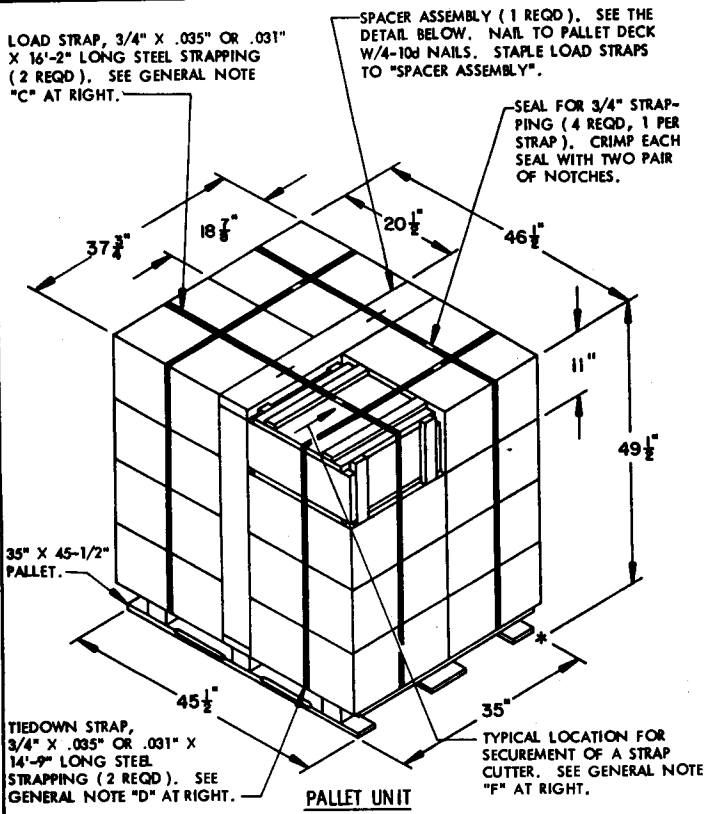

GENERAL NOTES

- A. THIS APPENDIX CANNOT STAND ALONE BUT MUST BE USED IN CONJUNCTION WITH THE BASIC UNITIZATION PROCEDURES DRAWING 19-48-4116-20PA1002. TO PRODUCE AN APPROVED UNIT LOAD, ALL PERTINENT PROCEDURES, SPECIFICATIONS AND CRITERIA SET FORTH WITHIN THE BASIC DRAWING WILL APPLY TO THE PROCEDURES DELINEATED IN THIS APPENDIX. ANY EXCEPTIONS TO THE BASIC PROCEDURES ARE SPECIFIED IN THIS APPENDIX.
- B. DIMENSIONS, CUBE AND WEIGHT OF A PALLET UNIT WILL VARY SLIGHTLY DEPENDING UPON THE ACTUAL DIMENSIONS OF THE BOXES AND THE WEIGHT OF THE SPECIFIC ITEM BEING UNITIZED.
- C. THE LOAD STRAPS MAY BE THREADED THROUGH THE STRAP SLOTS OF A PALLET OR PRE-POSITIONED ON THE PALLET DECK PRIOR TO PLACING BOXES ON THE PALLET.
- D. INSTALL EACH TIEDOWN STRAP TO PASS UNDER THE TOP DECK BOARDS OF THE PALLET AND TO BE LOCATED AS SHOWN. TIEDOWN STRAPS WILL BE TENSIONED AND SEALED PRIOR TO LOAD STRAPS.
- E. THE FOLLOWING DARCOM DRAWINGS ARE APPLICABLE FOR OUTLOADING AND STORAGE OF THE ITEMS COVERED BY THIS APPENDIX.
 - CARLOADING ----- DRAWING 19-48-4115-SPA1002
 - TRUCKLOADING ----- DRAWING 19-48-4117-11PA1003
 - STORAGE ----- DRAWING 19-48-4118-1-2-3-4-14-22PA1002
- F. FOR METHOD OF SECURING A STRAP CUTTER TO THE PALLET UNIT, SEE DARCOM DRAWING 19-48-4127-20P1000.
- G. IF ITEMS COVERED HEREIN ARE UNITIZED PRIOR TO ISSUANCE OF THIS APPENDIX, THE BOXES NEED NOT BE REUNITIZED SOLELY TO CONFORM TO THIS APPENDIX.
- H. THE UNITIZATION PROCEDURES DEPICTED HEREIN MAY ALSO BE USED FOR UNITIZING DETONATOR KITS WHEN IDENTIFIED BY DIFFERENT NATIONAL STOCK NUMBERS (NSN) THAN WHAT IS SHOWN ON THE TITLE PAGE, PROVIDED THE BOX PACK DOES NOT VARY FROM WHAT IS DELINEATED HEREIN. THE EXPLOSIVE CLASSIFICATION OF OTHER ITEMS MAY BE DIFFERENT THAN WHAT IS SHOWN.
- J. WHEN THE UNIT LOAD DEPICTED AT LEFT IS TO BE USED FOR UNITIZING MARINE CORPS AMMUNITION, ONE LAYER OF BOXES MUST BE OMITTED, TIEDOWN STRAP LENGTHS MUST BE DECREASED TO 12"-11", LOAD STRAP LENGTHS MUST BE DECREASED TO 14"-4", AND THE SPACER ASSEMBLY MUST BE MODIFIED. SPACER ASSEMBLY MODIFICATION INCLUDES CHANGING VERTICAL PIECE TO 33" AND CHANGING THE SUPPORT PIECE LENGTH TO 31". THIS WILL RESULT IN AN OVERALL UNIT HEIGHT OF 38-1/2", A GROSS UNIT WEIGHT OF 810 POUNDS, AND A UNIT CUBE OF 39.1 CUBE FEET. ADDITIONALLY, THE UNIT LOAD MAY BE MODIFIED AS DESCRIBE WHEN BEING SHIPPED BY MILVAN OR COMMERCIAL INTERMODAL CONTAINER, CONVENTIONAL VAN TRAILER OR CONVENTIONAL OR HIGH-CAPACITY BOXCAR. THE DETERMINATION TO REDUCE THE LOAD BY A LAYER FOR TRANSPORTATION WILL BE MADE BY THE RESPONSIBLE COMMAND AND WILL BE BASED UPON ECONOMICS OF TRANSPORTATION AND HANDLING.

16 BOXES OF DETONATOR KIT (50 PER BOX) @ 59 LBS	-----	944 LBS (APPROX)
DUNNAGE	-----	46 LBS
PALLET	-----	65 LBS
TOTAL WEIGHT	-----	1,055 LBS (APPROX)
CUBE	-----	50.3 CU FT (APPROX)

BILL OF MATERIAL

LUMBER	LINEAR FEET	BOARD FEET
2" X 6"	19.96	19.96
NAILES	NO. REQD	POUNDS
10d (3")	24	0.37
PALLET, 35" X 45-1/2"	1 REQD	65 LBS
STEEL STRAPPING, 3/4"	64.00 REQD	4.48 LBS
SEAL FOR 3/4" STRAPPING	4 REQD	NIL
STAPLE	2 REQD	NIL

