

APPENDIX 121V

UNITIZATION PROCEDURES FOR BOXED AMMUNITION AND COMPO- NENTS ON 4-WAY ENTRY PALLETS

**CAP, BLASTING, NON-ELECTRIC, M21 OR M23,
PACKED 40 OR 20 PER WOODEN BOX, UNITIZED 6
BOXES PER 40" X 48" PALLET; APPROX BOX SIZE
44" L X 16-3/8" W X 17-1/8" H**

NOTICE: THIS APPENDIX CANNOT STAND ALONE BUT MUST BE USED IN CONJUNCTION WITH THE BASIC UNITIZATION PROCEDURES DRAWING 19-48-4116-20PA1002.

DISTRIBUTION STATEMENT A:

**APPROVED FOR PUBLIC RELEASE
DISTRIBUTION IS UNLIMITED.**

U.S. ARMY MATERIEL COMMAND DRAWING

<p>APPROVED, U.S. ARMY RESEARCH, DEVELOPMENT AND ENGINEERING COMMAND</p> <p>REHMSTEDT.MA RK.J.1230548400</p> <p style="font-size: small;">Digitally signed by REHMSTEDT.MARK.J.1230548400 DN: cn=US, o=U.S. Government, ou=DoD, ou=PKI, ou=USA, c=US Date: 2013.01.23 15:40:10 -06'00'</p> <p style="text-align: right;">RDAR-EIL-TP</p>	<p style="text-align: center;">CAUTION: VERIFY PRIOR TO USE AT HTTPS://MHP.REDSTONE.ARMY.MIL THAT THIS IS THE MOST CURRENT VERSION OF THIS DOCUMENT. THIS IS PAGE 1 OF 4.</p>	DECEMBER 2012					
<p>APPROVED, U.S. ARMY JOINT MUNITIONS COMMAND</p> <p>CASILLAS.GILBE RT.J.1230393644</p> <p style="font-size: small;">Digitally signed by CASILLAS.GILBERT.J.1230393644 DN: cn=US, o=U.S. Government, ou=DoD, ou=PKI, ou=USA, c=US Date: 2013.01.18 10:53:10 -06'00'</p> <p style="text-align: right;">AMSJM-LIT</p>	DO NOT SCALE	MORGAN SENNETT					
<p>APPROVED BY ORDER OF COMMANDING GENERAL, U.S. ARMY MATERIEL COMMAND</p> <p>SHIMP.UPTON .R.1231257183</p> <p style="font-size: small;">Digitally signed by SHIMP.UPTON.R.1231257183 DN: cn=US, o=U.S. Government, ou=DoD, ou=PKI, ou=USA, c=US Date: 2013.01.24 08:16:20 -06'00'</p> <p style="text-align: center;">U.S. ARMY DEFENSE AMMUNITION CENTER</p>	<p>ENGINEERING DIVISON</p> <p>TEST ENGINEER</p> <p>EXPLOSIVES SAFETY DIRECTORATE</p>	<p>FIEFFER.LAUR A.A.1230375727</p> <p>WILLIAMS.KENY ON.L.1231212392</p>	<p>Digitally signed by FIEFFER.LAURA.A.1230375727 DN: cn=US, o=U.S. Government, ou=DoD, ou=PKI, ou=USA, c=US Date: 2013.01.16 11:01:04 -06'00'</p> <p>Digitally signed by WILLIAMS.KENYON.L.1231212392 DN: cn=US, o=U.S. Government, ou=DoD, ou=PKI, ou=USA, c=US Date: 2013.01.17 09:05:27 -06'00'</p>	CLASS	DIVISION	DRAWING	FILE
	19	48	4116/ 121V	20PA1002			

PALLET UNIT DATA				
ITEMS INCLUDED		*HAZARD CLASS AND DIVISION	*COMPATIBILITY GROUP	APPROX WEIGHT (LBS)
NSN	DODIC			
1375-				
01-494-6945	MN88	1.4	S	843
01-567-3615	MN88	1.4	S	843
01-494-6941	MN90	1.4	S	735
01-567-3620	MN90	1.4	S	735

*HAZARD CLASSIFICATION DATA CONTAINED IN THE ABOVE CHART IS FOR GUIDANCE AND INFORMATIONAL PURPOSES ONLY. VERIFICATION OF THE SPECIFIED DATA SHOULD BE MADE BY CONSULTING THE MOST RECENT JOINT HAZARD CLASSIFICATION SYSTEM LISTING OR OTHER APPROVED LISTING(S).

GENERAL NOTES

- A. THIS APPENDIX CANNOT STAND ALONE BUT MUST BE USED IN CONJUNCTION WITH THE BASIC UNITIZATION PROCEDURES DRAWING 19-48-4116-20PA1002. TO PRODUCE AN APPROVED UNIT LOAD, ALL PERTINENT PROCEDURES, SPECIFICATIONS AND CRITERIA SET FORTH WITHIN THE BASIC DRAWING WILL APPLY TO THE PROCEDURES DELINEATED IN THIS APPENDIX. ANY EXCEPTIONS TO THE BASIC PROCEDURES ARE SPECIFIED IN THIS APPENDIX.
- B. DIMENSIONS, CUBE AND WEIGHT OF A PALLET UNIT WILL VARY SLIGHTLY DEPENDING UPON THE ACTUAL DIMENSIONS OF THE BOXES AND THE WEIGHT OF THE SPECIFIC ITEM BEING UNITIZED.
- C. THE LOAD STRAPS MAY BE THREADED THROUGH THE STRAP SLOTS OF A PALLET OR PRE-POSITIONED ON THE PALLET DECK PRIOR TO PLACING THE BOXES ON THE PALLET. LOAD STRAPS MUST BE TENSIONED AND SEALED PRIOR TO APPLICATION OF TIEDOWN STRAPS.
- D. INSTALL EACH TIEDOWN STRAP TO PASS UNDER THE DECK BOARDS OF THE PALLET AND TO BE LOCATED AS SHOWN. TIEDOWN STRAPS WILL NOT BE APPLIED UNTIL THE LOAD STRAPS HAVE BEEN TENSIONED AND SEALED.
- E. THE FOLLOWING AMC DRAWINGS ARE APPLICABLE FOR OUTLOADING AND STORAGE OF THE ITEMS COVERED BY THIS APPENDIX.

CARLOADING	- - - -	19-48-4115-5PA1002
TRUCKLOADING	- - - -	19-48-4117-11PA1003
STORAGE	- - - -	19-48-4118-1-2-3-4-14-22PA1002
END OPENING ISO		
CONTAINER	- - - -	19-48-4153-15PA1002
MILVAN	- - - -	19-48-4166-15PA1003
SIDE OPENING ISO		
CONTAINER	- - - -	19-48-4267-15PA1009
- F. IF ITEMS COVERED HEREIN ARE UNITIZED PRIOR TO ISSUANCE OF THIS APPENDIX, THE BOXES NEED NOT BE REUNITIZED SOLELY TO CONFORM TO THIS APPENDIX.
- G. THE UNITIZATION PROCEDURES DEPICTED HEREIN MAY ALSO BE USED FOR UNITIZING BLASTING CAPS WHEN IDENTIFIED BY DIFFERENT NATIONAL STOCK NUMBERS (NSN) THAN WHAT IS SHOWN ON PAGE 2, PROVIDED THE BOX PACK DOES NOT VARY FROM WHAT IS DELINEATED HEREIN. THE EXPLOSIVE CLASSIFICATION OF OTHER ITEMS MAY BE DIFFERENT THAN WHAT IS SHOWN.
- H. THE STYLE 1 PALLET DELINEATED IN THE DETAIL AT LEFT NEED NOT HAVE CHAMFERS OR STRAP SLOTS AS SPECIFIED WITHIN MILITARY SPECIFICATION MIL-P-15011 WHEN USED FOR THE UNITIZATION OF ITEMS COVERED BY THIS APPENDIX.
- J. FOR DETAILS OF THE MIL-DTL-2427 WOODEN BOX SEE ARDEC DRAWING 13023565 (M21) OR 13023566 (M23).

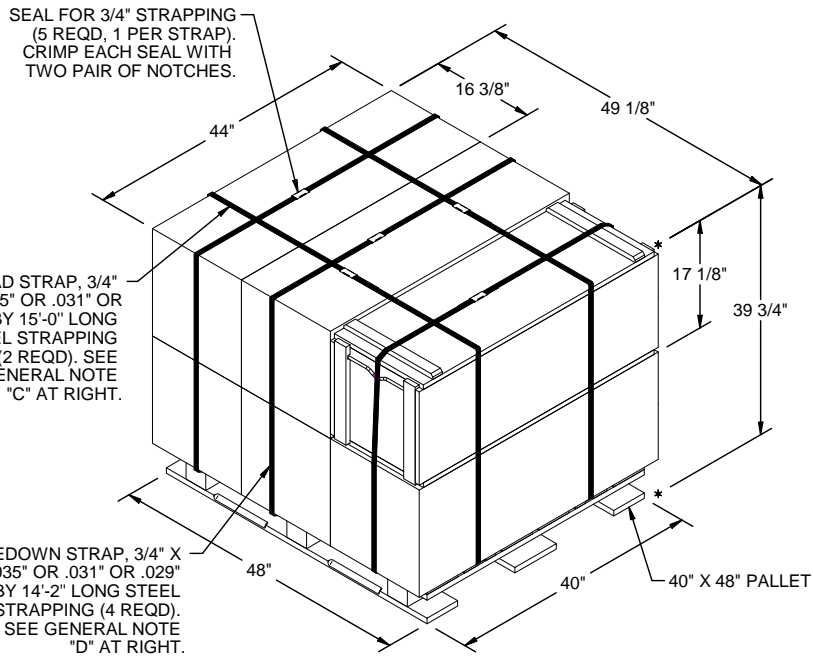

PALLET UNIT
SEE GENERAL NOTE "B" AT RIGHT.

6 BOXES OF BLASTING CAPS (40 PER BOX) @ 126 LBS	- - - - -	756 LBS
DUNNAGE	- - - - -	7 LBS
PALLET	- - - - -	80 LBS
<hr/>		
TOTAL WEIGHT	- - - - -	843 LBS (APPROX)
CUBE	- - - - -	49.7 CU FT (APPROX)

BILL OF MATERIAL			
PALLET, 40" X 48"	- - - - -	1 RECD	- - - - - 80 LBS
STEEL STRAPPING, 3/4"	- 72.50'	RECD	- - - - - 6.42 LBS
SEAL FOR 3/4" STRAPPING	- - - - -	5 RECD	- - - - - NIL

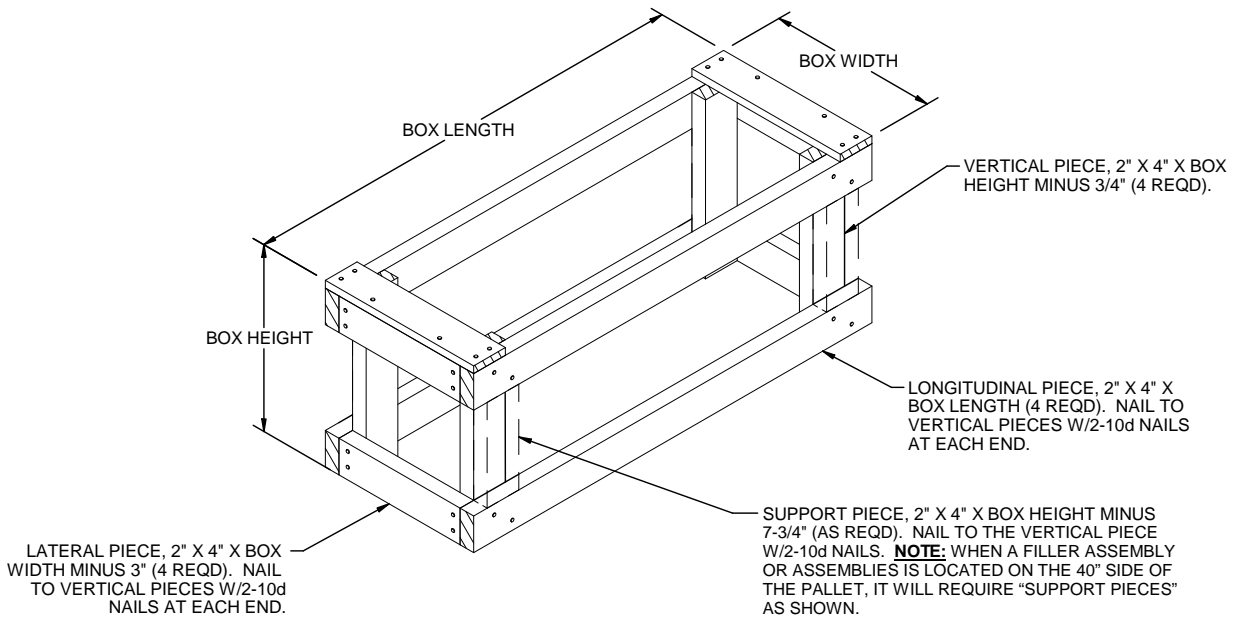

FILLER ASSEMBLY
(FOR MINUS ONE BOX)