

APPENDIX 121H

UNITIZING PROCEDURES FOR BOXED AMMUNITION AND COMPONENTS ON 4-WAY ENTRY PALLETS

CAP, BLASTING, SPECIAL ELECTRIC DELAY,
PACKED 500 PER WOODEN BOX, UNITIZED 10
BOXES PER 40" X 48" PALLET; APPROX BOX
SIZE 35-3/4" L X 20-5/8" W X 10-5/16" H

NOTICE: THIS APPENDIX CANNOT STAND ALONE BUT MUST BE USED IN CONJUNCTION WITH
THE BASIC UNITIZATION PROCEDURES DRAWING 19-48-4116-20PA1002.

DISTRIBUTION STATEMENT A.

APPROVED FOR PUBLIC RELEASE;
DISTRIBUTION IS UNLIMITED.

U.S. ARMY MATERIEL COMMAND DRAWING			
APPROVED, U.S. ARMY INDUSTRIAL OPERATIONS COMMAND <i>10/1/82</i> <i>Russell Pickens</i> <i>Timothy F...</i> AMSTA-AR-ESK AMSIO-TMJ		DRAFTSMAN BETTY KUNDERT ENGINEER SANDRA M. SCHULTZ	SUPPLY ENGINEERING DIVISION TRANSPORTATION ENGINEERING DIVISION VALIDATION ENGINEERING DIVISION
APPROVED BY ORDER OF COMMANDING GENERAL, U.S. ARMY MATERIEL COMMAND <i>Arthur J. ...</i> U.S. ARMY DEFENSE AMMUNITION CENTER		LOGISTICS ENGINEERING OFFICE <i>[Signature]</i> DECEMBER 1982	
REVISION NO. 1 OCTOBER 1997 SEE THE REVISION LISTING ON PAGE 2		CLASS 19	DIVISION 48
		DRAWING 4116/ 121H	FILE 20PA 1002

DO NOT SCALE

PALLET UNIT DATA				
ITEMS INCLUDED		HAZARD CLASS AND DIVISION ●		APPROX WEIGHT LBS
NSN	DODIC	OD CLASS	COMP GROUP	
1375-				
00-056-2799	M091	1.1	B	848
00-056-2800	M092	1.1	B	848
00-056-2801	M093	1.1	B	848
00-056-2802	M094	1.1	B	848
00-056-2803	M095	1.1	B	848
00-529-8517	M101	1.1	B	848
00-529-8518	M102	1.1	B	848
00-529-8515	M103	1.1	B	848
00-529-8520	M104	1.1	B	848
00-529-8519	M107	1.1	B	848
00-529-8521	M108	1.1	B	848
00-529-8522	M117	1.1	B	848
00-529-8523	M118	1.1	B	848
00-529-8516	M128	1.1	B	848
00-516-5634	M129	1.1	B	848

● HAZARD CLASSIFICATION DATA CONTAINED IN THE ABOVE CHART IS FOR GUIDANCE AND INFORMATIONAL PURPOSES ONLY. VERIFICATION OF THE SPECIFIED DATA SHOULD BE MADE BY CONSULTING THE MOST RECENT JOINT HAZARD CLASSIFICATION SYSTEM LISTING OR OTHER APPROVED LISTING(S).

REVISION

REVISION NO. 1, DATED OCTOBER 1997, CONSISTS OF:

1. ADDING ITEM BY NATIONAL STOCK NUMBER (NSN) TO "PALLET UNIT DATA" CHART.
2. CHANGING DRAWING NOMENCLATURE.
3. CHANGING BOX SIZE.
4. UPDATING TO CAD.

GENERAL NOTES

SEAL FOR 3/4" STRAPPING (6 REQD, 1 PER STRAP). CRIMP EACH SEAL WITH TWO PAIR OF NOTCHES.

TIEDOWN STRAP, 3/4" X .035" OR .031" X 13'-11" LONG STEEL STRAPPING. (5 REQD). SEE GENERAL NOTE "D" AT RIGHT.

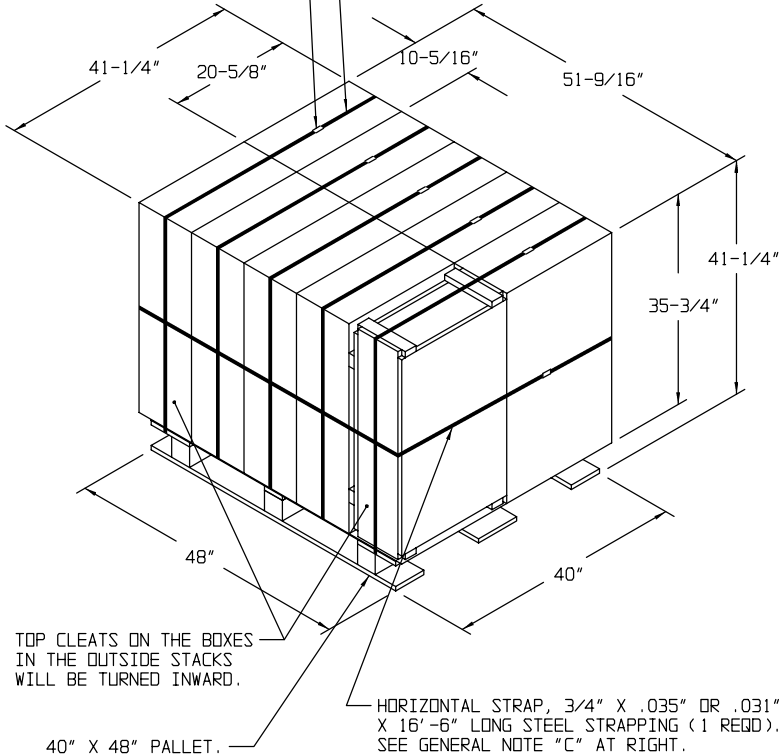

PALLET UNIT

SEE GENERAL NOTE "B" AT RIGHT.

10 BOXES OF BLASTING CAPS (500 PER BOX) AT 76 LBS	---	760 LBS (APPROX)
DUNNAGE	---	8 LBS
PALLET	---	80 LBS
<hr/>		
TOTAL WEIGHT	---	848 LBS (APPROX)
CUBE	---	50.8 CU FT (APPROX)

BILL OF MATERIAL

PALLET, 40" X 48"	---	1 REQD	---	80 LBS
STEEL STRAPPING, 3/4"	---	86.1' REQD	---	7.69 LBS
SEAL FOR 3/4" STRAPPING	---	6 REQD	---	NIL

- A. THIS APPENDIX CANNOT STAND ALONE BUT MUST BE USED IN CONJUNCTION WITH THE BASIC UNITIZATION PROCEDURES DRAWING 19-48-4116-20PA1002. TO PRODUCE AN APPROVED UNIT LOAD, ALL PERTINENT PROCEDURES, SPECIFICATIONS AND CRITERIA SET FORTH WITHIN THE BASIC DRAWING WILL APPLY TO THE PROCEDURES DELINEATED IN THIS APPENDIX. ANY EXCEPTIONS TO THE BASIC PROCEDURES ARE SPECIFIED IN THIS APPENDIX.
- B. DIMENSIONS, CUBE AND WEIGHT OF A PALLET UNIT WILL VARY SLIGHTLY DEPENDING UPON THE ACTUAL DIMENSIONS OF THE BOXES AND THE WEIGHT OF THE SPECIFIC ITEM BEING UNITIZED.
- C. INSTALL THE HORIZONTAL STRAP TO ENCIRCLE THE LAYER OF BOXES ON THE PALLET. HORIZONTAL STRAP MUST BE TENSIONED AND SEALED PRIOR TO THE APPLICATION OF TIEDOWN STRAPS.
- D. INSTALL EACH TIEDOWN STRAP TO PASS UNDER THE TOP DECK/STRINGER BOARDS OF THE PALLET AND TO BE LOCATED AS SHOWN. TIEDOWN STRAPS WILL NOT BE APPLIED UNTIL THE HORIZONTAL STRAP HAS BEEN TENSIONED AND SEALED.
- E. THE FOLLOWING AMC DRAWINGS ARE APPLICABLE FOR OUTLOADING AND STORAGE OF THE ITEMS COVERED BY THIS APPENDIX.
 - CARLOADING - - - - 19-48-4115-5PA1002
 - TRUCKLOADING - - - - 19-48-4117-11PA1003
 - STORAGE - - - - - 19-48-4118-1-2-3-4-14-22PA1002
 - END OPENING ISO CONTAINER - - - - - 19-48-4153-15PA1002
 - MILVAN - - - - - 19-48-4166-15PA1003
 - SIDE OPENING ISO CONTAINER - - - - - 19-48-4267-15PA1009
- F. IF ITEMS COVERED HEREIN ARE UNITIZED PRIOR TO ISSUANCE OF THIS APPENDIX, THE BOXES NEED NOT BE REUNITIZED SOLELY TO CONFORM TO THIS APPENDIX.
- G. IF THERE IS A NEED TO USE THE FILLER ASSEMBLIES AND AT LEAST TWO PALLET UNITS ARE BEING CONSTRUCTED, NOT MORE THAN 6 FILLERS WILL BE INSTALLED IN ANY ONE PALLET UNIT. USING TWO PALLET UNITS TO SATISFY THE PALLETIZATION CRITERIA APPLICABLE TO LESS-THAN-FULL PALLET UNITS IS AN EXCEPTION TO THE BASIC PROCEDURES. HOWEVER, THE EXCEPTION IS NECESSARY FOR THE AMMUNITION PACK COVERED BY THIS APPENDIX, TO MOST EFFECTIVELY GET AN ACCEPTABLE, COMPACT AND SOUND PALLET UNIT.
- H. THE UNITIZATION PROCEDURES DEPICTED HEREIN MAY ALSO BE USED FOR UNITIZING BLASTING CAPS WHEN IDENTIFIED BY DIFFERENT NATIONAL STOCK NUMBERS (NSN) THAN WHAT IS SHOWN ON PAGE 2, PROVIDED THE BOX PACK DOES NOT VARY FROM WHAT IS DELINEATED HEREIN. THE EXPLOSIVE CLASSIFICATION OF OTHER ITEMS MAY BE DIFFERENT THAN WHAT IS SHOWN.
- J. THE STYLE 1 PALLET DELINEATED IN THE DETAIL AT LEFT NEED NOT HAVE CHAMFERS OR STRAP SLOTS AS SPECIFIED WITHIN MILITARY SPECIFICATION MIL-P-15011 WHEN USED FOR THE UNITIZATION OF ITEMS COVERED BY THIS APPENDIX.
- K. FOR DETAILS OF THE WOODEN MIL-B-2427, TYPE II, CLASS 2 BOX SEE NAVSEA DRAWING NUMBER 2128449.

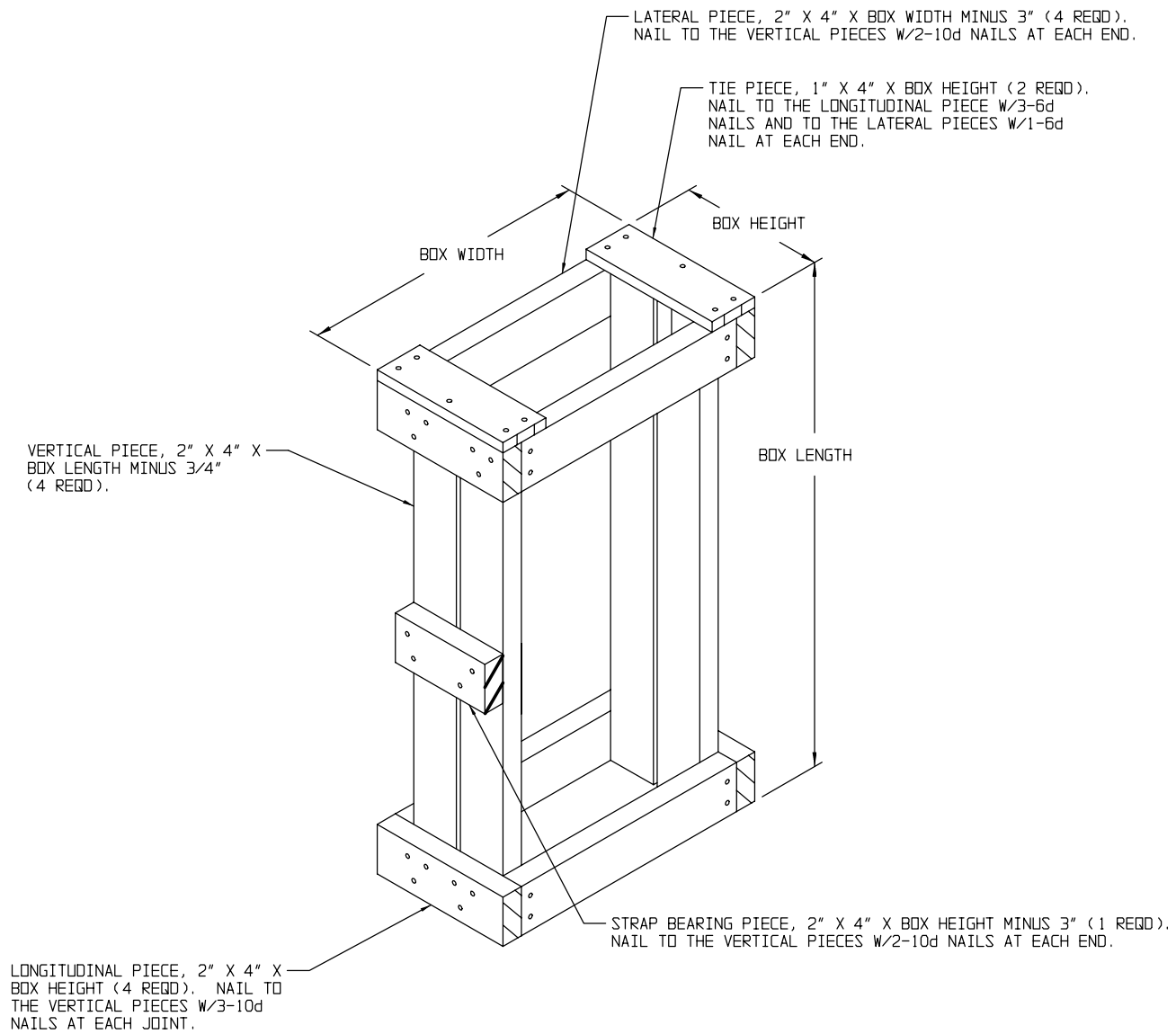

FILLER ASSEMBLY
(FOR MINUS ONE BOX)