

APPENDIX 121A

UNITIZATION PROCEDURES FOR BOXED AMMUNITION AND COMPONENTS ON 4-WAY ENTRY PALLETS

BLASTING CAP, NONELECTRIC, M7, PACKED 480 PER
WOODEN BOX, UNITIZED 27 BOXES PER 35" X 45 1/2"
PALLET; APPROX BOX SIZE 16 3/8" L X 11 1/4" W X
11 3/4" H

PALLET UNIT DATA						
ITEMS INCLUDED		HAZARD CLASSIFICATION ①				WEIGHT (LBS)
NSN	DODIC	DOT CLASS	CG CLASS	QD CLASS	COMP GROUP	
1375- 01-193-2976	M131	A	VIII	1.1	B	746

REVISIONS

REVISION NO. 1, DATED AUGUST 1985, CONSISTS OF:

1. CHANGING BOX DIMENSIONS.
2. CHANGING QUANTITY PER UNIT PACK.
3. UPDATING PALLET UNIT TO CONFORM TO 1 ABOVE.

REVISION NO. 2, DATED MAY 1986, CONSISTS OF:

CHANGING BOX DIMENSIONS.

NOTICE: THIS APPENDIX CANNOT STAND ALONG BUT MUST
BE USED IN CONJUNCTION WITH THE BASIC UNITIZATION
PROCEDURES DRAWING 19-48-4116-20PA1002.

① HAZARD CLASSIFICATION DATA CONTAINED IN THE ABOVE CHART IS FOR GUIDANCE AND INFORMATIONAL PURPOSES ONLY. VERIFICATION OF THE SPECIFIED DATA SHOULD BE MADE BY CONSULTING THE MOST RECENT JOINT HAZARD CLASSIFICATION SYSTEM LISTING OR OTHER APPROVED LISTING (S).

REVISIONS		DESIGNED BY P. B. B. / W. B. / H. W. / M. W. (P. 2)	FIELD NO.	MARK (P. 2)
1	AUG 85	Martin DARCOM-ESK AMSC-TND	RST	Quilley
APPROVED, U. S. ARMY ARMAMENT MATERIAL READINESS COMMAND				
2	MAY 86	Martin DARCOM-ESK AMSC-TND William Ernst	DRAR-LEP	DRAR-TND William Ernst
APPROVED BY ORDER OF COMMANDING GENERAL, U. S. ARMY MATERIEL DEVELOPMENT AND READINESS COMMAND (DARCOM)				
U. S. ARMY DEFENSE SUBSTITUTION CENTER AND SCHOOL				
U. S. ARMY DARCOM DRAWING				
MARCH 1983				
CLASS	DIVISION	DRAWING	FILE	
19	48	4116/ 121A	20PA 1002	

DO NOT SCALE

SEAL FOR 3/4" STRAPPING
(6 REQD, 1 PER STRAP).
CRIMP EACH SEAL WITH TWO
PAIR OF NOTCHES.

TIEDOWN STRAP, 3/4" X .035" OR
.031" X 12'-7" LONG STEEL STRAPPING
(3 REQD). SEE GENERAL NOTE "D"
AT RIGHT.

TOP CLEATS ON THE BOXES
IN THE OUTSIDE STACKS WILL
BE TURNED INWARD, EXCEPT
AS OTHERWISE SPECIFIED IN
MIL-STD-129.

HORIZONTAL STRAP,
3/4" X .035" OR .031"
X 15'-1" LONG STEEL
STRAPPING (3 REQD).
SEE GENERAL NOTE
"C" AT RIGHT.

35" X 45-1/2"
PALLET.

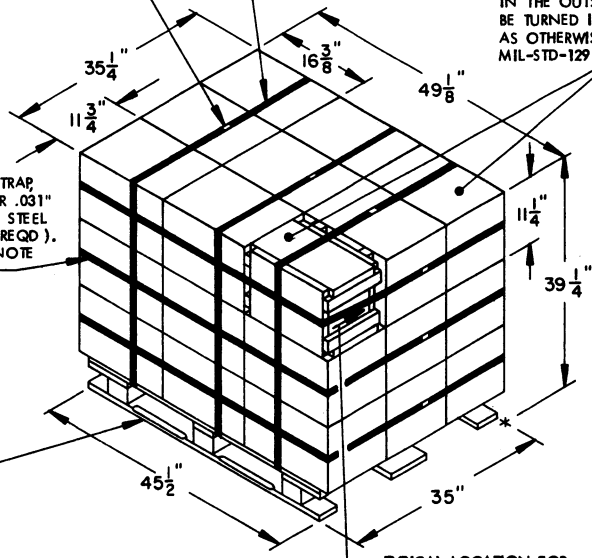

TYPICAL LOCATION FOR
SECUREMENT OF A STRAP
CUTTER. SEE GENERAL
NOTE "F" AT RIGHT.

PALLET UNIT

SEE GENERAL NOTE "B" AT RIGHT.

27 BOXES OF BLASTING CAPS (480 PER BOX) @ 25 LBS ----- 675 LBS (APPROX)
DUNNAGE ----- 6 LBS
PALLET ----- 65 LBS

TOTAL WEIGHT ----- 746 LBS (APPROX)
CUBE ----- 39.3 CU FT (APPROX)

BILL OF MATERIAL

PALLET, 35" X 45-1/2" ----- 1 REQD ----- 65 LBS
STEEL STRAPPING, 3/4" ----- 83.00' REQD ----- 5.93LBS
SEAL FOR 3/4" STRAPPING -- 6 REQD ----- NIL

GENERAL NOTES

- A. THIS APPENDIX CANNOT STAND ALONE BUT MUST BE USED IN CONJUNCTION WITH THE BASIC UNITIZATION PROCEDURES DRAWING 19-48-4116-20PA1002. TO PRODUCE AN APPROVED UNIT LOAD, ALL PERTINENT PROCEDURES, SPECIFICATIONS AND CRITERIA SET FORTH WITHIN THE BASIC DRAWING WILL APPLY TO THE PROCEDURES DELINEATED IN THIS APPENDIX. ANY EXCEPTIONS TO THE BASIC PROCEDURES ARE SPECIFIED IN THIS APPENDIX.
- B. DIMENSIONS, CUBE AND WEIGHT OF A PALLET UNIT WILL VARY SLIGHTLY DEPENDING UPON THE ACTUAL DIMENSIONS OF THE BOXES AND THE WEIGHT OF THE SPECIFIC ITEM BEING UNITIZED.
- C. INSTALL EACH HORIZONTAL STRAP TO ENCIRCLE A LAYER OF BOXES ON THE PALLET. HORIZONTAL STRAPS MUST BE TENSIONED AND SEALED PRIOR TO APPLICATION OF TIEDOWN STRAPS.
- D. INSTALL EACH TIEDOWN STRAP TO PASS UNDER THE TOP DECK BOARDS OF THE PALLET AND TO BE LOCATED AS SHOWN. TIEDOWN STRAPS WILL NOT BE APPLIED UNTIL THE HORIZONTAL STRAPS HAVE BEEN TENSIONED AND SEALED.
- E. THE FOLLOWING AMC (DARCOM) DRAWINGS ARE APPLICABLE FOR OUTLOADING AND STORAGE OF THE ITEMS COVERED BY THIS APPENDIX.

CARLOADING ----- DRAWING 19-48-4115-5PA1002
TRUCKLOADING ----- DRAWING 19-48-4117-11PA1003
STORAGE ----- DRAWING 19-48-4118-1-2-3-4-14-22PA1002
- F. FOR METHOD OF SECURING A STRAP CUTTER TO THE PALLET UNIT, SEE DARCOM DRAWING 19-48-4127-20P1000.
- G. IF ITEMS COVERED HEREIN ARE UNITIZED PRIOR TO ISSUANCE OF THIS APPENDIX, THE BOXES NEED NOT BE REUNITIZED SOLELY TO CONFORM TO THIS APPENDIX.
- H. THE UNITIZATION PROCEDURES DEPICTED HEREIN MAY ALSO BE USED FOR UNITIZING BLASTING CAPS WHEN IDENTIFIED BY DIFFERENT NATIONAL STOCK NUMBERS (NSN) THAN WHAT IS SHOWN ON THE TITLE PAGE, PROVIDED THE BOX PACK DOES NOT VARY FROM WHAT IS DELINEATED HEREIN. THE EXPLOSIVE CLASSIFICATION OF OTHER ITEMS MAY BE DIFFERENT THAN WHAT IS SHOWN.

LATERAL PIECE, 2" X 4" X BOX
HEIGHT (4 REQD). NAIL TO
VERTICAL PIECES W/2-10d
NAILS AT EACH END.

SUPPORT PIECE,
2" X 4" X CUT-TO-
FIT IN LENGTH
(AS REQD). NAIL TO
A VERTICAL PIECE W/2-10d
NAILS. NOTE: WHEN
A FILLER ASSEMBLY IS
LOCATED IN AN OUTER
STACK ON A 45-1/2" SIDE
OF THE PALLET, "FILLER
PIECES" WILL BE REQUIRED
TO BE POSITIONED AS
SHOWN.

LONGITUDINAL PIECE, 2" X 4"
X BOX LENGTH MINUS 3" (4 REQD).
NAIL TO VERTICAL PIECES W/2-10d
NAILS AT EACH END.

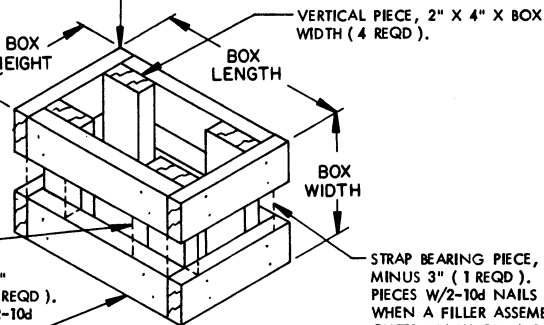

FILLER ASSEMBLY
(FOR MINUS ONE BOX)

STRAP BEARING PIECE, 2" X 4" X BOX HEIGHT
MINUS 3" (1 REQD). NAIL TO THE VERTICAL
PIECES W/2-10d NAILS AT EACH END. NOTE:
WHEN A FILLER ASSEMBLY IS LOCATED IN AN
OUTER STACK ON A 35" SIDE OF THE PALLET,
A "STRAP BEARING PIECE" WILL BE REQUIRED
TO BE POSITIONED UNDER THE HORIZONTAL
STRAP. STAPLE STRAP TO THE "STRAP BEARING
PIECE".