

## APPENDIX 121

# UNITIZATION PROCEDURES FOR BOXED AMMUNITION AND COMPONENTS ON 4-WAY ENTRY PALLETS

CAP, BLASTING, NONELECTRIC, SPECIAL, PACKED  
5,000 PER WOODEN BOX, UNITIZED 8 BOXES PER  
35" X 45 $\frac{1}{2}$ " PALLET; APPROX BOX SIZE 23 $\frac{7}{8}$ "L X  
16 $\frac{1}{4}$ "W X 10 $\frac{1}{4}$ "H

PALLET UNIT DATA						
ITEMS INCLUDED		HAZARD CLASSIFICATION				WEIGHT (LBS)
NSN	DODIC	DOT CLASS	CG CLASS	OD CLASS	COMP GROUP	
1375-00-028-5226	M131	A	VIII	1.1	B	748

NOTICE: THIS APPENDIX CANNOT STAND ALONE BUT  
MUST BE USED IN CONJUNCTION WITH THE BASIC  
UNITIZATION PROCEDURES DRAWING 19-48-4116-20PA1002.

REVISIONS				DRAFTSMAN <i>GRG/mgh</i>	PROJ ENG <i>GBF/ALM</i>
				CHECKER <i>GRG</i>	LDR ENGNG OFFICE <i>GBF</i>
APPROVED, U. S. ARMY ARMAMENT MATERIEL READINESS COMMAND					
				<i>Lawrence Kester</i>	<i>John J. ...</i>
				DARSAR-MAD	DARSAR-TMD
APPROVED BY ORDER OF COMMANDING GENERAL, U. S. ARMY MATERIEL DEVELOPMENT AND READINESS COMMAND (DARCOM)					
<i>John J. ...</i>					
U. S. ARMY DEFENSE AMMUNITION CENTER AND SCHOOL					
U. S. ARMY DARCOM DRAWING					
JUNE 1980					
CLASS	DIVISION	DRAWING	FILE		
19	48	4116/121	20PA 1002		

**DO NOT SCALE**

**GENERAL NOTES**

- A. THIS APPENDIX CANNOT STAND ALONE BUT MUST BE USED IN CONJUNCTION WITH THE BASIC UNITIZATION PROCEDURES DRAWING 19-48-4116-20PA1002. TO PRODUCE AN APPROVED UNIT LOAD, ALL PERTINENT PROCEDURES, SPECIFICATIONS AND CRITERIA SET FORTH WITHIN THE BASIC DRAWING WILL APPLY TO THE PROCEDURES DELINEATED IN THIS APPENDIX. ANY EXCEPTIONS TO THE BASIC PROCEDURES ARE SPECIFIED IN THIS APPENDIX.
- B. DIMENSIONS, CUBE AND WEIGHT OF A PALLET UNIT WILL VARY SLIGHTLY DEPENDING UPON THE ACTUAL DIMENSIONS OF THE BOXES AND THE WEIGHT OF THE SPECIFIC ITEM BEING UNITIZED.
- C. THE LOAD STRAPS MAY BE THREADED THROUGH THE STRAP SLOTS OF A PALLET OR PRE-POSITIONED ON THE PALLET DECK PRIOR TO PLACING BOXES ON THE PALLET.
- D. INSTALL EACH TIEDOWN STRAP TO PASS UNDER THE TOP DECK BOARDS OF THE PALLET AND TO BE LOCATED AS SHOWN. TIEDOWN STRAPS WILL BE TENSIONED AND SEALED PRIOR TO THE LOAD STRAPS.
- E. THE FOLLOWING DARCOM DRAWINGS ARE APPLICABLE FOR OUTLOADING AND STORAGE OF THE ITEMS COVERED BY THIS APPENDIX.
  - CARLOADING ----- DRAWING 19-48-4115-SPA1002
  - TRUCKLOADING ----- DRAWING 19-48-4117-11PA1003
  - STORAGE ----- DRAWING 19-48-4118-1-2-14-22PA1002
- F. FOR METHOD OF SECURING A STRAP CUTTER TO THE PALLET UNIT, SEE DARCOM DRAWING 19-48-4127-20P1000.
- G. IF ITEMS COVERED HEREIN ARE UNITIZED PRIOR TO ISSUANCE OF THIS APPENDIX, THE BOXES NEED NOT BE REUNITIZED SOLELY TO CONFORM TO THIS APPENDIX.
- H. THE UNITIZATION PROCEDURES DEPICTED HEREIN MAY ALSO BE USED FOR UNITIZING BLASTING CAPS WHEN IDENTIFIED BY DIFFERENT NATIONAL STOCK NUMBERS (NSN) THAN WHAT IS SHOWN ON THE TITLE PAGE, PROVIDED THE BOX PACK DOES NOT VARY FROM WHAT IS DELINEATED HEREIN. THE EXPLOSIVE CLASSIFICATION OF OTHER ITEMS MAY BE DIFFERENT THAN WHAT IS SHOWN.

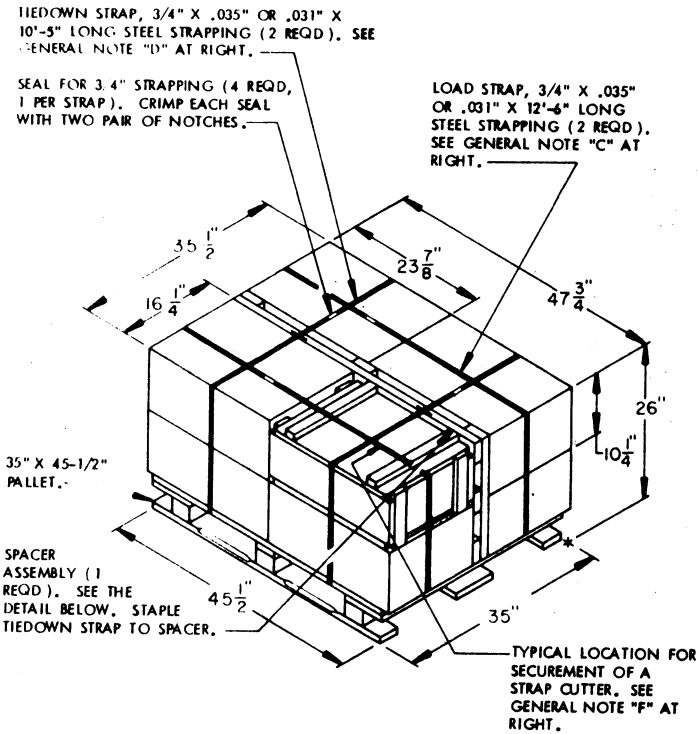

**PALLET UNIT**

SEE GENERAL NOTE "B" AT RIGHT.

8 BOXES OF BLASTING CAP (5,000 PER BOX) @ 82 LBS -----	656 LBS (APPROX)
DUNNAGE -----	27 LBS
PALLET -----	65 LBS
<b>TOTAL WEIGHT -----</b>	<b>748 LBS (APPROX)</b>
<b>CUBE -----</b>	<b>25.5 CU FT (APPROX)</b>

BILL OF MATERIAL		
LUMBER	LINEAR FEET	BOARD FEET
2" X 4"	16.88	11.25
NAILS	NO. REQD	POUNDS
10d (3")	18	0.28
PALLET, 35" X 45-1/2" -----	1 REQD -----	65 LBS
STEEL STRAPPING, 3/4" -----	45.83 REQD -----	3.27 LBS
SEAL FOR 3/4" STRAPPING -----	4 REQD -----	NIL
STAPLE -----	2 REQD -----	NIL

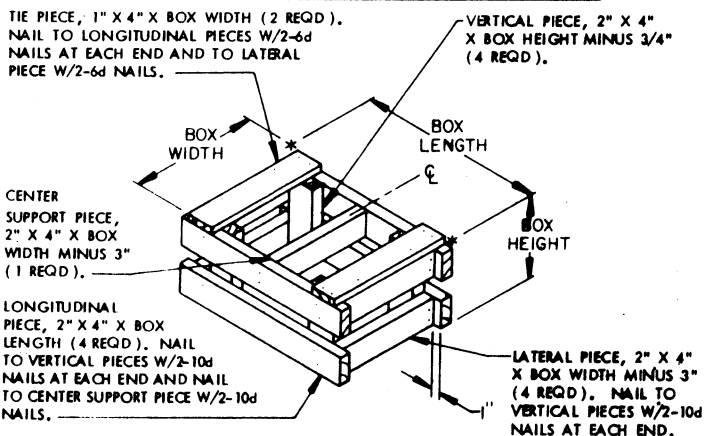

**FILLER ASSEMBLY**  
(FOR MINUS ONE BOX)

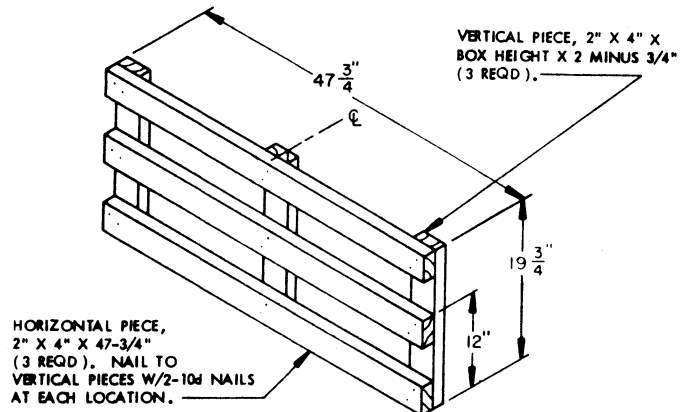

**SPACER ASSEMBLY**  
(1 REQD)