

APPENDIX 120Q

UNITIZATION PROCEDURES FOR BOXED AMMUNITION AND COMPONENTS ON 4-WAY ENTRY PALLETS

CHARGE, DEMOLITION, MK 36, PACKED 5 PER METAL
DRUM, UNITIZED 12 DRUMS PER 35" X 45 1/2"
PALLET; DRUM SIZE 11 1/2" DIA X 23" H

PALLET UNIT DATA						
ITEMS INCLUDED		HAZARD CLASSIFICATION ①				WEIGHT (LBS)
NSN	DODIC	DOT CLASS	CG CLASS	QD CLASS	COMP GROUP	
1375- 00-316-3610	M976	A	IX-B	1.1	D	1,044

REVISION

REVISION NO. 1, DATED AUGUST 1986, CONSISTS OF:
CHANGING QUANTITY PER UNIT PACK.

NOTICE: THIS APPENDIX CANNOT STAND ALONE BUT MUST BE USED IN
CONJUNCTION WITH THE BASIC UNITIZATION PROCEDURES DRAWING
19-48-4116-20PA1002.

① HAZARD CLASSIFICATION DATA CONTAINED IN THE ABOVE CHART IS FOR
GUIDANCE AND INFORMATIONAL PURPOSES ONLY. VERIFICATION OF
THE SPECIFIED DATA SHOULD BE MADE BY CONSULTING THE MOST
RECENT JOINT HAZARD CLASSIFICATION SYSTEM LISTING OR OTHER
APPROVED LISTING (S).

REVISIONS		DRAWN BY BJS/K/ST	PROJ ENG WRE/KRF	CHKD BY WPK/RJ
1	AUG 86	M. H. ... SINCAR-ESK	J. ... ANSMC-TND	W. ... LOS ENGINE OFFICE
APPROVED, U. S. ARMY ARMAMENT MATERIEL READINESS COMMAND				
<div style="display: flex; justify-content: space-between;"> <div style="text-align: center;"> <i>John L. Byrd</i> <small>DEBAR-LTY</small> </div> <div style="text-align: center;"> <i>John L. Byrd</i> <small>DEBAR-TND</small> </div> </div>				
APPROVED BY ORDER OF COMMANDING GENERAL, U. S. ARMY MATERIEL DEVELOPMENT AND READINESS COMMAND (DARCOM)				
<i>John L. Byrd</i> <small>U. S. ARMY DEFENSE AMMUNITION CENTER AND SCHOOL</small>				
U. S. ARMY DARCOM DRAWING				
AUGUST 1981				
CLASS	DIVISION	DRAWING	FILE	
19	48	4116/ 120Q	20PA 1002	

DO NOT SCALE

GENERAL NOTES

- A. THIS APPENDIX CANNOT STAND ALONE BUT MUST BE USED IN CONJUNCTION WITH THE BASIC UNITIZATION PROCEDURES DRAWING 19-48-4116-20PA1002. TO PRODUCE AN APPROVED UNIT LOAD, ALL PERTINENT PROCEDURES, SPECIFICATIONS AND CRITERIA SET FORTH WITHIN THE BASIC DRAWING WILL APPLY TO THE PROCEDURES DELINEATED IN THIS APPENDIX. ANY EXCEPTIONS TO THE BASIC PROCEDURES ARE SPECIFIED IN THIS APPENDIX.
- B. DIMENSIONS, CUBE AND WEIGHT OF A PALLET UNIT WILL VARY SLIGHTLY DEPENDING UPON THE ACTUAL DIMENSIONS OF THE DRUMS AND THE WEIGHT OF THE SPECIFIC ITEM BEING UNITIZED.
- C. INSTALL EACH HORIZONTAL STRAP TO ENCIRCLE A DUNNAGE ASSEMBLY. HORIZONTAL STRAPS MUST BE TENSIONED AND SEALED PRIOR TO APPLICATION OF TIEDOWN STRAPS.
- D. INSTALL EACH TIEDOWN STRAP TO PASS UNDER THE TOP DECK BOARDS OF THE PALLET AND TO BE LOCATED AS SHOWN. TIEDOWN STRAPS WILL NOT BE APPLIED UNTIL THE HORIZONTAL STRAPS HAVE BEEN TENSIONED AND SEALED.
- E. THE FOLLOWING AMC (DARCOM) DRAWINGS ARE APPLICABLE FOR OUTLOADING AND STORAGE OF THE ITEMS COVERED BY THIS APPENDIX.
 CARLOADING ----- DRAWING 19-48-4115-5PA1002
 TRUCKLOADING -- DRAWING 19-48-4117-11PA1003
 STORAGE ----- DRAWING 19-48-4118-1-2-3-4-14-22PA-1002
- F. FOR METHOD OF SECURING A STRAP CUTTER TO THE PALLET UNIT, SEE DARCOM DRAWING 19-48-4127-20P1000.
- G. IF ITEMS COVERED HEREIN ARE UNITIZED PRIOR TO ISSUANCE OF THIS APPENDIX, THE DRUMS NEED NOT BE REUNITIZED SOLELY TO CONFORM TO THIS APPENDIX.
- H. THE UNITIZATION PROCEDURES DEPICTED HEREIN MAY ALSO BE USED FOR UNITIZING DEMOLITION CHARGES WHEN IDENTIFIED BY DIFFERENT NATIONAL STOCK NUMBERS (NSN) THAN WHAT IS SHOWN ON THE TITLE PAGE, PROVIDED THE DRUM DOES NOT VARY FROM WHAT IS DELINEATED HEREIN. THE EXPLOSIVE CLASSIFICATION OF OTHER ITEMS MAY BE DIFFERENT THAN WHAT IS SHOWN.
- J. IF THERE IS A NEED TO USE FILLER ASSEMBLIES AND AT LEAST TWO PALLET UNITS ARE BEING CONSTRUCTED, NOT MORE THAN 8 FILLERS WILL BE INSTALLED IN ANY ONE PALLET UNIT. ADDITIONAL FILLERS CAN BE PLACED IN A SECOND PALLET UNIT AS REQUIRED WHEN THE QUANTITY OF 8 FILLERS IN THE FIRST REDUCED PALLET IS INSUFFICIENT TO SATISFY THE TOTAL REDUCTION NEEDED. USING TWO PALLET UNITS TO SATISFY THE PALLETIZATION CRITERIA APPLICABLE TO LESS-THAN-FULL PALLET UNITS IS AN EXCEPTION TO THE BASIC PROCEDURES. HOWEVER, THE EXCEPTION IS NECESSARY FOR THE AMMUNITION PACK COVERED BY THIS APPENDIX, TO MOST EFFECTIVELY OBTAIN AN ACCEPTABLE, COMPACT AND SOUND PALLET UNIT.

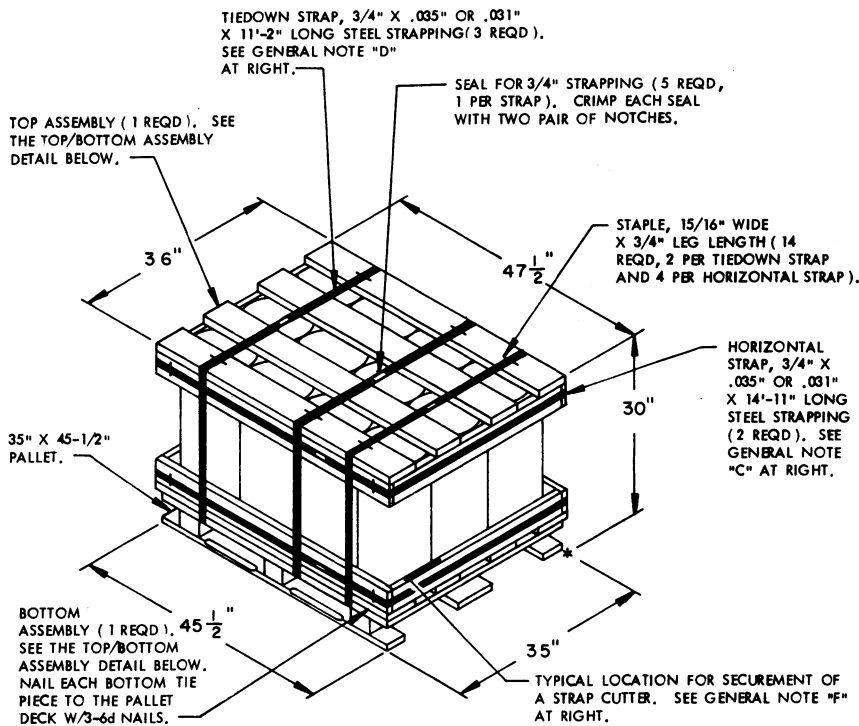

PALLET UNIT

SEE GENERAL NOTE "B" AT RIGHT.

12 DRUMS OF DEMOLITION CHARGES (5 PER DRUM) @ 77 LBS-----	924 LBS (APPROX)
DUNNAGE-----	55 LBS
PALLET-----	65 LBS

TOTAL WEIGHT-----	1,044 LBS (APPROX)
CUBE-----	29.7 CU FT (APPROX)

BILL OF MATERIAL		
LUMBER	LINEAR FEET	BOARD FEET
1" X 4"	27.33	9.11
1" X 6"	31.67	15.83
NAILS		POUNDS
6d (2")	88	0.52
PALLET, 35" X 45-1/2"----- 1 REQD ----- 65 LBS		
STEEL STRAPPING, 3/4"----- 63.33' REQD ----- 4.52 LBS		
SEAL FOR 3/4" STRAPPING----- 5 REQD ----- NIL		
STAPLE, 15/16" X 3/4"----- 14 REQD ----- NIL		

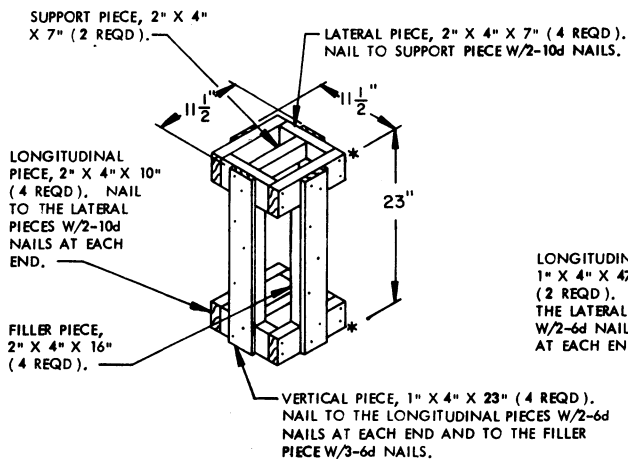

FILLER ASSEMBLY

(FOR MINUS ONE DRUM)

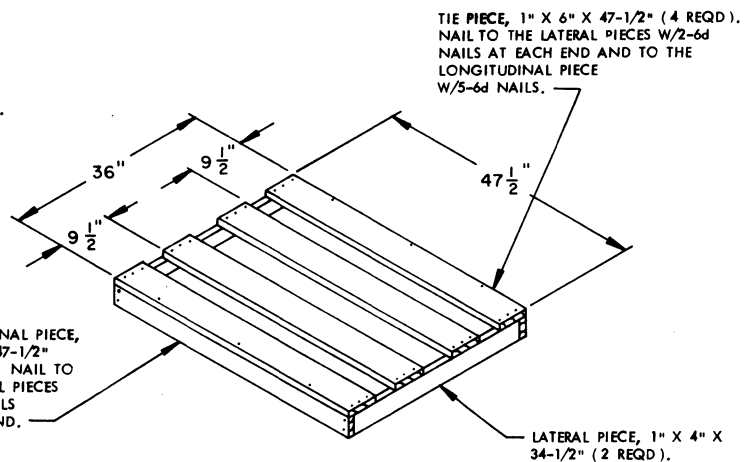

TOP/BOTTOM ASSEMBLY

(2 REQD)