

APPENDIX 120P

UNITIZATION PROCEDURES FOR BOXED AMMUNITION AND COMPONENTS ON 4-WAY ENTRY PALLETS

CHARGE , DEMOLITION, PRACTICE, PACKED 1 PER
WOODEN BOX, UNITIZED 50 BOXES PER 35" X 45 $\frac{1}{2}$ "
PALLET; APPROX BOX SIZE 19" L X 9 $\frac{5}{8}$ " W X 6 $\frac{7}{8}$ " H

PALLET UNIT DATA						
ITEMS INCLUDED		HAZARD CLASSIFICATION				WEIGHT (LBS)
NSN	DODIC	DOT CLASS	CG CLASS	QD CLASS	COMP GROUP	
1375- 00-433-7778	M784	---	---	---	---	2,622

NOTICE: THIS APPENDIX CANNOT STAND ALONE BUT MUST BE USED
IN CONJUNCTION WITH THE BASIC UNITIZATION PROCEDURES
DRAWING 19-48-4116-20PA1002.

REVISIONS				DRAFTSMAN 423 WRE/WW	PRED. DES. WRE/WW
				CHECKED RIG	LAW ENGINEER K. Miller
APPROVED, U. S. ARMY ARMAMENT MATERIEL READINESS COMMAND					
			 OSAR-LEP OSAR-THD APPROVED BY ORDER OF COMMANDING GENERAL, U. S. ARMY MATERIEL, DEVELOPMENT AND READINESS COMMAND (DARCOM) U.S. ARMY DEFENSE ARMAMENT CENTER AND SCHOOL		
U. S. ARMY DARCOM DRAWING					
MARCH 1983					
CLASS	DIVISION	DRAWING	FILE		
19	48	4116/ 120P	20PA 1002		

DO NOT SCALE

GENERAL NOTES

- A. THIS APPENDIX CANNOT STAND ALONE BUT MUST BE USED IN CONJUNCTION WITH THE BASIC UNITIZATION PROCEDURES DRAWING 19-48-4116-20PA1002. TO PRODUCE AN APPROVED UNIT LOAD, ALL PERTINENT PROCEDURES, SPECIFICATIONS AND CRITERIA SET FORTH WITHIN THE BASIC DRAWING WILL APPLY TO THE PROCEDURES DELINEATED IN THIS APPENDIX. ANY EXCEPTIONS TO THE BASIC PROCEDURES ARE SPECIFIED IN THIS APPENDIX.
- B. DIMENSIONS, CUBE AND WEIGHT OF A PALLET UNIT WILL VARY SLIGHTLY DEPENDING UPON THE ACTUAL DIMENSIONS OF THE BOXES AND THE WEIGHT OF THE SPECIFIC ITEM BEING UNITIZED.
- C. THE LOAD STRAPS MAY BE THREADED THROUGH THE STRAP SLOTS OF A PALLET OR PRE-POSITIONED ON THE PALLET DECK PRIOR TO PLACING BOXES ON THE PALLET. LOAD STRAPS MUST BE TENSIONED AND SEALED PRIOR TO APPLICATION OF TIEDOWN STRAPS.
- D. INSTALL EACH TIEDOWN STRAP TO PASS UNDER THE DECK/STRINGER BOARDS OF THE PALLET AND TO BE LOCATED AS SHOWN. TIEDOWN STRAPS WILL NOT BE APPLIED UNTIL THE LOAD STRAPS HAVE BEEN TENSIONED AND SEALED.
- E. THE FOLLOWING DARCOM DRAWINGS ARE APPLICABLE FOR OUT-LOADING AND STORAGE OF THE ITEMS COVERED BY THIS APPENDIX.
 CARLOADING -----DRAWING 19-48-4115-5PA1002
 TRUCKLOADING ----DRAWING 19-48-4117-11PA1003
 STORAGE -----DRAWING 19-48-4118-1-2-3-4-14-22PA1002
- F. FOR METHOD OF SECURING A STRAP CUTTER TO THE PALLET UNIT, SEE DARCOM DRAWING 19-48-4127-20P1000.
- G. IF ITEMS COVERED HEREIN ARE UNITIZED PRIOR TO ISSUANCE OF THIS APPENDIX, THE BOXES NEED NOT BE REUNITIZED SOLELY TO CONFORM TO THIS APPENDIX.
- H. THE UNITIZATION PROCEDURES DEPICTED HEREIN MAY ALSO BE USED FOR UNITIZING DEMOLITION CHARGES WHEN IDENTIFIED BY DIFFERENT NATIONAL STOCK NUMBERS (NSN) THAN WHAT IS SHOWN ON THE TITLE PAGE, PROVIDED THE BOX PACK DOES NOT VARY FROM WHAT IS DELINEATED HEREIN. THE EXPLOSIVE CLASSIFICATION OF OTHER ITEMS MAY BE DIFFERENT THAN WHAT IS SHOWN.

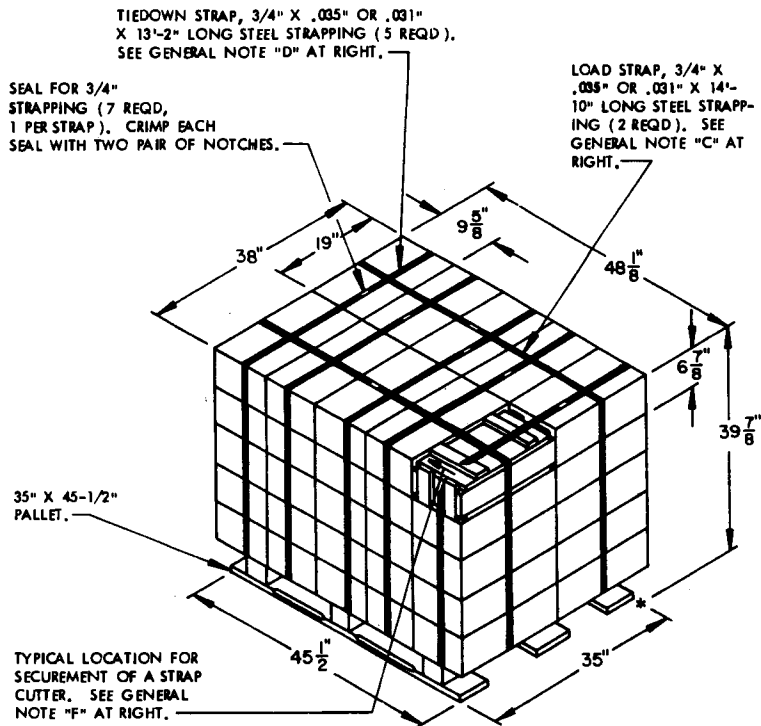

PALLET UNIT

SEE GENERAL NOTE "B" AT RIGHT.

50 BOXES OF DEMOLITION CHARGES (1 PER BOX) @ 51 LBS -----	2,550 LBS (APPROX)
DUNNAGE -----	7 LBS
PALLET -----	65 LBS
TOTAL WEIGHT -----	2,622 LBS (APPROX)
CUBE -----	42.2 CU FT (APPROX)

BILL OF MATERIAL

PALLET, 35" X 45-1/2" -----	1 REQD -----	65 LBS
STEEL STRAPPING, 3/4" -----	95.50' REQD -----	6.82 LBS
SEAL FOR 3/4" STRAPPING -----	7 REQD -----	NIL

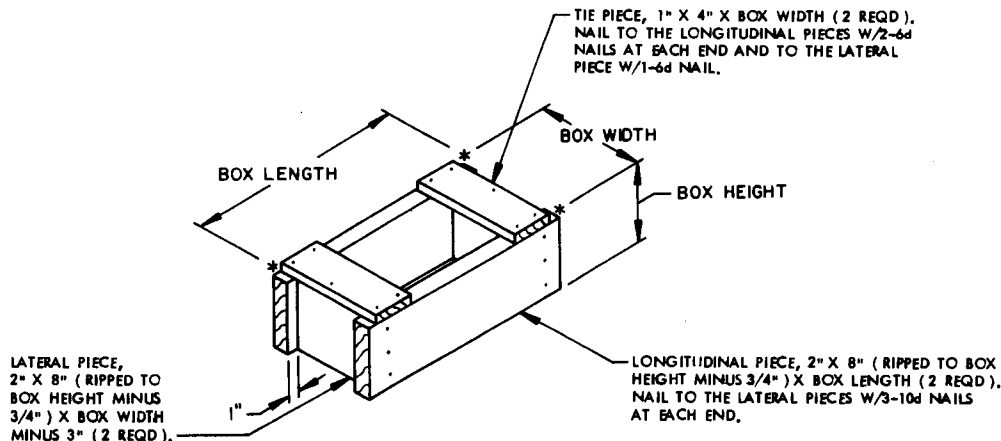

FILLER ASSEMBLY

(FOR MINUS ONE BOX)