

# APPENDIX 120G

## UNITIZATION PROCEDURES FOR BOXED AMMUNITION AND COMPO- NENTS ON 4-WAY ENTRY PALLETS

**CHARGE, ASSEMBLY, DEMOLITION, PACKED 2  
PER WOODEN BOX, UNITIZED 36 BOXES PER 35"  
X 45-1/2" PALLET; APPROX BOX SIZE 16-1/8" L X  
11-3/16" W X 12-3/8" H**

**NOTICE: THIS APPENDIX CANNOT STAND ALONE BUT MUST BE USED IN CONJUNCTION WITH THE BASIC UNITIZATION  
PROCEDURES DRAWING 19-48-4116-20PA1002.**

**DISTRIBUTION STATEMENT A:**

**APPROVED FOR PUBLIC RELEASE  
DISTRIBUTION IS UNLIMITED.**

### U.S. ARMY MATERIEL COMMAND DRAWING

<b>APPROVED, U.S. ARMY RESEARCH, DEVELOPMENT AND ENGINEERING COMMAND</b> PISKORIK.DAVID. A.1229069167 <small>Digitally signed by PISKORIK.DAVID.A.1229069167 DN: cn=PISKORIK.DAVID.A.1229069167, c=US, o=U.S. Government, ou=DOD, PK, USA Date: 2008.08.20 07:28:33 -0500</small>		<b>CAUTION: VERIFY PRIOR TO USE AT WWW.DAC.ARMY.MIL THAT THIS IS THE MOST CURRENT VERSION OF THIS DOCUMENT. THIS IS PAGE 1 OF 4.</b>			
<b>APPROVED, U.S. ARMY JOINT MUNITIONS COMMAND</b> CASILLAS.GILBERT. J.1230393644 <small>Digitally signed by CASILLAS.GILBERT. J.1230393644 DN: cn=US, o=U.S. Government, ou=DOD, ou=PKI, ou=USA, cn=CASILLAS.GILBERT. J.1230393644 Date: 2008.08.20 08:14:55 -0500</small>		<b>DO NOT SCALE</b>		<b>MARCH 1983</b>	
AMSRD-AAR-AIL-TP(R)		ENGINEER OR TECHNICIAN	BASIC REV.	GEORGE B. FECKE  RANDY DUNN	
<b>APPROVED BY ORDER OF COMMANDING GENERAL, U.S. ARMY MATERIEL COMMAND</b> CARNEY.GARY. BURTON.10387 08038 <small>Digitally signed by CARNEY.GARY. BURTON.1038708038 DN: cn=US, o=U.S. Government, ou=DoD, ou=PKI, ou=USA, cn=CARNEY.GARY. BURTON.1038708038 Date: 2008.07.01 10:19:18 -0500</small>		TRANSPORTATION ENGINEERING DIVISION		FIEFFER.LAURA. A.1230375727 <small>Digitally signed by FIEFFER.LAURA. A.1230375727 DN: cn=US, o=U.S. Government, ou=DOD, ou=PKI, ou=USA, cn=FIEFFER.LAURA. A.1230375727 Date: 2008.05.20 08:52:52 -0500</small>	
AMSJM-LIT		VALIDATION ENGINEERING DIVISION	BEAVER. JERRY. W.1230949952 <small>Digitally signed by BEAVER.JERRY. W.1230949952 DN: cn=US, o=U.S. Government, ou=PKI, ou=USA, cn=BEAVER.JERRY W.1230949952 Date: 2008.05.20 12:52:25 -0500</small>	TESTED	REVISION NO. 3
U.S. ARMY DEFENSE AMMUNITION CENTER		ENGINEERING DIRECTORATE		NORTUNEN.LARRY. R.1230549628 <small>Digitally signed by NORTUNEN.LARRY. R.1230549628 DN: cn=US, o=U.S. Government, ou=DOD, ou=PKI, ou=USA, cn=NORTUNEN.LARRY. R.1230549628 Date: 2008.05.20 12:49:49 -0500</small>	
				CLASS  <b>19</b>	DIVISION  <b>48</b>
				DRAWING  <b>4116/ 120G</b>	FILE  <b>20PA1002</b>
				<b>SEE THE REVISION LISTING ON PAGE 2</b>	

PALLET UNIT DATA				
ITEMS INCLUDED		*HAZARD CLASS AND DIVISION	*COMPATIBILITY GROUP	APPROX WEIGHT (LBS)
NSN	DODIC			
1375-				
00-028-5245	M756	1. 1	D	2, 127
00-926-3985	M757	1. 1	D	2, 127
01-398-0060	M757	1. 1	D	2, 127

\*HAZARD AND CLASSIFICATION DATA CONTAINED IN THE ABOVE CHART IS FOR GUIDANCE AND INFORMATIONAL PURPOSES ONLY. VERIFICATION OF THE SPECIFIED DATA SHOULD BE MADE BY CONSULTING THE MOST RECENT JOINT HAZARD CLASSIFICATION SYSTEM LISTING OR OTHER APPROVED LISTING(S).

### REVISIONS

REVISION NO. 1, DATED OCTOBER 1983, CONSISTS OF:

1. CHANGING BOX DIMENSIONS.
2. UPDATING DRAWING FORMAT.

REVISION NO. 2, DATED MARCH 1996, CONSISTS OF:

1. ADDING ITEM BY NATIONAL STOCK NUMBER (NSN) TO "PALLET UNIT DATA" CHART.
2. DELETED GENERAL NOTE "F" AND CHANGED LETTER OF OTHER GENERAL NOTES ACCORDINGLY.

REVISION NO. 3, DATED JUNE 2008, CONSISTS OF:

1. ADDING ITEM BY NATIONAL STOCK NUMBER (NSN) TO "PALLET UNIT DATA" CHART.
2. REORIENTING CORNER TOP LAYER BOXES IAW ECP R07K3014.

**GENERAL NOTES**

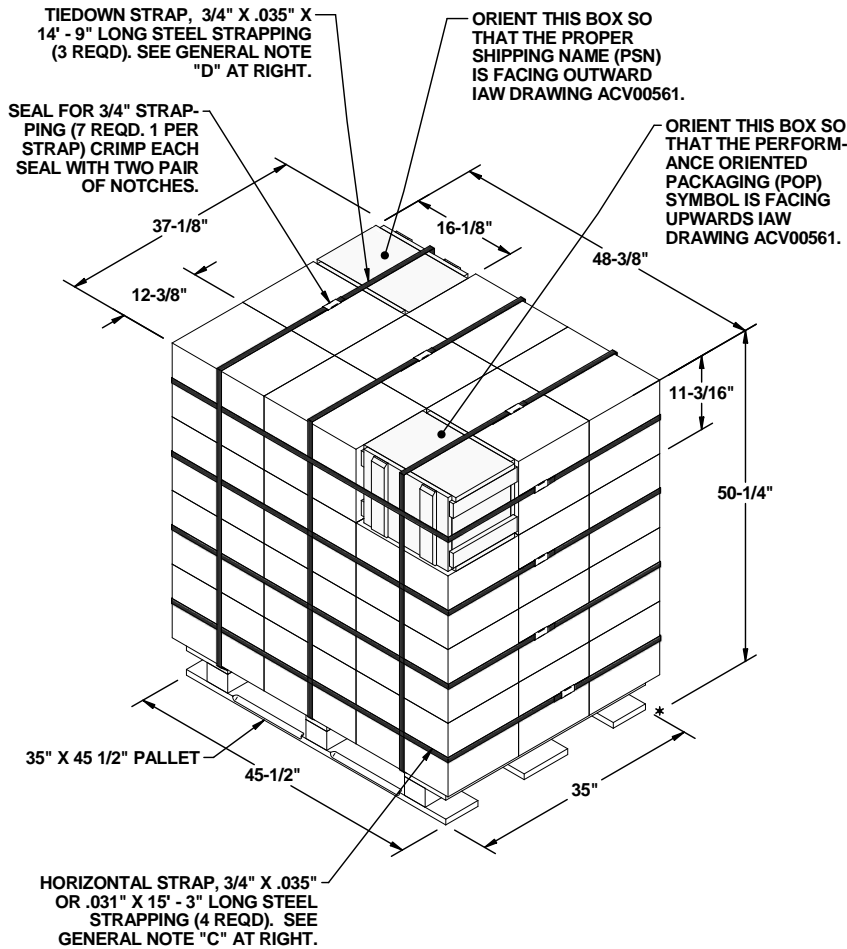

**PALLET UNIT**  
SEE GENERAL NOTE "B" AT RIGHT.

36 BOXES OF DEMOLITION CHARGE (2 PER BOX) AT 57 LBS	---	2,052 LBS
DUNNAGE	---	10 LBS
PALLET	---	65 LBS
<b>TOTAL WEIGHT</b>	---	<b>2,127 LBS (APPROX)</b>
<b>CUBE</b>	---	<b>52.2 CU FT (APPROX)</b>

BILL OF MATERIAL	
PALLET, 35" x 45-1/2"	1 REQD - - - - - 65 LBS
STEEL STRAPPING, 3/4"	105.25' REQD - - - - - 9.40 LBS
SEAL FOR 3/4" STRAPPING	7 REQD - - - - - NIL

- A. THIS APPENDIX CANNOT STAND ALONE BUT MUST BE USED IN CONJUNCTION WITH THE BASIC UNITIZATION PROCEDURES DRAWING 19-48-4116-20PA1002. TO PRODUCE AN APPROVED UNIT LOAD, ALL PERTINENT PROCEDURES, SPECIFICATIONS AND CRITERIA SET FORTH WITHIN THE BASIC DRAWING WILL APPLY TO THE PROCEDURES DELINEATED IN THIS APPENDIX. ANY EXCEPTIONS TO THE BASIC PROCEDURES ARE SPECIFIED IN THIS APPENDIX.
- B. DIMENSIONS, CUBE AND WEIGHT OF A PALLET UNIT WILL VARY SLIGHTLY DEPENDING UPON THE ACTUAL DIMENSIONS OF THE BOXES AND THE WEIGHT OF THE SPECIFIC ITEM BEING UNITIZED.
- C. INSTALL EACH HORIZONTAL STRAP TO ENCIRCLE A LAYER OF BOXES ON THE PALLET. NOTE THAT THE STRAPS WILL BE LOCATED AS SHOWN. HORIZONTAL STRAPS MUST BE TENSIONED AND SEALED PRIOR TO THE APPLICATION OF TIEDOWN STRAPS.
- D. INSTALL EACH TIEDOWN STRAP TO PASS UNDER THE TOP DECK BOARDS OF THE PALLET AND TO BE LOCATED AS SHOWN. TIEDOWN STRAPS WILL NOT BE APPLIED UNTIL THE HORIZONTAL STRAPS HAVE BEEN TENSIONED AND SEALED.
- E. THE FOLLOWING AMC DRAWINGS ARE APPLICABLE FOR OUTLOADING AND STORAGE OF THE ITEMS COVERED BY THIS APPENDIX.
  - CARLOADING - - - - - 19-48-4115-5PA1002
  - TRUCKLOADING - - - - - 19-48-4117-11PA1003
  - STORAGE - - - - - 19-48-4118-1-2-3-4-14-22PA1002
  - END OPENING ISO CONTAINER - - - - - 19-48-4153-15PA1002
  - MILVAN - - - - - 19-48-4166-15PA1003
  - SIDE OPENING ISO CONTAINER - - - - - 19-48-4267-15PA1009
- F. IF ITEMS COVERED HEREIN ARE UNITIZED PRIOR TO ISSUANCE OF THIS REVISION TO THIS APPENDIX, THE BOXES NEED NOT BE REUNITIZED SOLELY TO CONFORM TO THIS REVISION.
- G. THE UNITIZATION PROCEDURES DEPICTED HEREIN MAY ALSO BE USED FOR UNITIZING DEMOLITION CHARGE ASSEMBLIES WHEN IDENTIFIED BY DIFFERENT NATIONAL STOCK NUMBERS (NSN) THAN WHAT IS SHOWN ON PAGE 2, PROVIDED THE BOX PACK DOES NOT VARY FROM WHAT IS DELINEATED HEREIN. THE EXPLOSIVE CLASSIFICATION OF OTHER ITEMS MAY BE DIFFERENT THAN WHAT IS SHOWN.
- H. WHEN THE UNIT LOAD DEPICTED AT LEFT IS TO BE USED FOR UNITIZING MARINE CORPS AMMUNITION, ONE LAYER OF BOXES MUST BE OMITTED, TIEDOWN STRAP LENGTHS MUST BE DECREASED TO 12'-11", AND ONE HORIZONTAL STRAP MUST BE OMITTED. THIS WILL RESULT IN AN OVERALL UNIT HEIGHT OF 39", A GROSS UNIT WEIGHT OF 1,611 POUNDS, AND A UNIT CUBE OF 40.6 CUBIC FEET. ADDITIONALLY, THE UNIT MAY BE MODIFIED AS DESCRIBED WHEN BEING SHIPPED BY MILVAN OR ISO INTERMODAL FREIGHT CONTAINER, VAN TRAILER, OR BOXCAR. THE DETERMINATION TO REDUCE THE LOAD BY A LAYER FOR TRANSPORTATION WILL BE MADE BY THE RESPONSIBLE COMMAND AND WILL BE BASED UPON ECONOMICS OF TRANSPORTATION AND HANDLING.
- J. THE STYLE 1A PALLET DELINEATED IN THE DETAIL AT LEFT NEED NOT HAVE CHAMFERS OR STRAP SLOTS AS SPECIFIED WITHIN MILITARY SPECIFICATION MIL-P-15011 WHEN USED FOR THE UNITIZATION OF ITEMS COVERED BY THIS APPENDIX.
- K. FOR DETAILS OF THE WOODEN BOX SEE ARDEC DRAWING 8883618.

VERTICAL PIECE, 2" X 4"  
X BOX WIDTH MINUS 3/4"  
(4 REQD).

TIE PIECE, 1" X 4" X BOX LENGTH (2 REQD).  
NAIL TO LATERAL PIECES W/1-6d NAIL AT  
EACH END AND TO LONGITUDINAL PIECE  
W/2-6d NAILS.

BOX HEIGHT

BOX LENGTH

BOX WIDTH

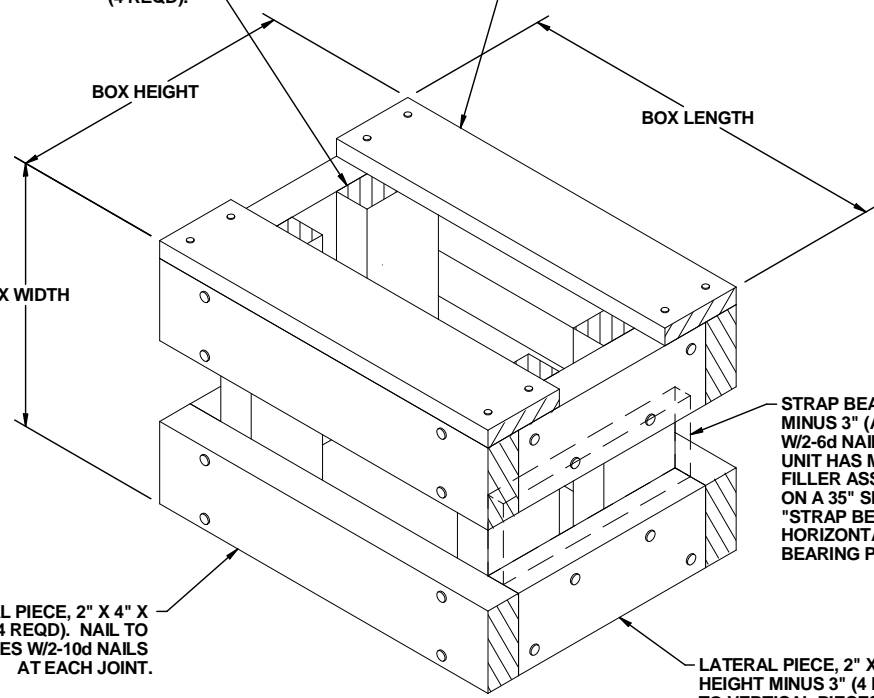

STRAP BEARING PIECE, 1" X 4" X BOX HEIGHT  
MINUS 3" (AS REQD). NAIL TO VERTICAL PIECES  
W/2-6d NAILS AT EACH END. NOTE: WHEN A  
UNIT HAS MORE THAN ONE BOX OMITTED, A  
FILLER ASSEMBLY LOCATED IN AN OUTER STACK  
ON A 35" SIDE OF THE PALLET WILL REQUIRE A  
"STRAP BEARING PIECE" POSITIONED UNDER THE  
HORIZONTAL STRAP. STAPLE STRAP TO "STRAP  
BEARING PIECE".

LONGITUDINAL PIECE, 2" X 4" X  
BOX LENGTH (4 REQD). NAIL TO  
VERTICAL PIECES W/2-10d NAILS  
AT EACH JOINT.

LATERAL PIECE, 2" X 4" X BOX  
HEIGHT MINUS 3" (4 REQD). NAIL  
TO VERTICAL PIECES W/2-10d NAILS  
AT EACH END.

**FILLER ASSEMBLY**  
(FOR MINUS ONE BOX)