

APPENDIX 120F

UNITIZATION PROCEDURES FOR BOXED AMMUNITION AND COMPONENTS ON 4-WAY ENTRY PALLETS

CHARGE, DEMOLITION, BLOCK, PACKED 20 PER
WIREBOUND BOX, UNITIZED 24 BOXES PER 35"
45-1/2" PALLET; APPROX BOX SIZE 17-5/8" L
X 13-7/8" W X 8" H

NOTICE: THIS APPENDIX CANNOT STAND ALONE BUT MUST BE USED IN CONJUNCTION WITH
THE BASIC UNITIZATION PROCEDURES DRAWING 19-48-4116-20PA1002.

DISTRIBUTION STATEMENT A.

APPROVED FOR PUBLIC RELEASE;
DISTRIBUTION IS UNLIMITED.

U. S. ARMY MATERIEL COMMAND DRAWING			
APPROVED, U. S. ARMY INDUSTRIAL OPERATIONS COMMAND <i>NLH</i> <i>David L. Robinson</i> AMSTA-AR-ESK	DRAFTSMAN ENGINEER BETTY J. KUNDERT SANDRA M. SCHULTZ		
<i>Stuckwisch</i> AMSIO-TMJ	SUPPLY ENGINEERING DIVISION <i>Sparger</i>	TRANSPORTATION ENGINEERING DIVISION <i>G. L. Willis</i>	VALIDATION ENGINEERING DIVISION <i>J. H. Kohn</i>
APPROVED BY ORDER OF COMMANDING GENERAL, U. S. ARMY MATERIEL COMMAND <i>Amy W. [Signature]</i>	LOGISTICS ENGINEERING OFFICE <i>Thomas J. [Signature]</i>		
U. S. ARMY DEFENSE AMMUNITION CENTER AND SCHOOL	JULY 1980		
REVISION NO. 1	SEPTEMBER 1995	CLASS 19	DIVISION 48
SEE THE REVISION LISTING ON PAGE 2		DRAWING 4116/ 120F	FILE 20PA 1002

DO NOT SCALE

PALLET UNIT DATA				
ITEMS INCLUDED		HAZARD CLASS AND DIVISION ●		APPROX WEIGHT LBS
NSN	DODIC	OD CLASS	COMP GROUP	
1375-00-728-5941	MO24	1.1	D	1,343
01-399-3718	MO24	1.1	D	1,343

- HAZARD CLASSIFICATION DATA CONTAINED IN THE ABOVE CHART IS FOR GUIDANCE AND INFORMATIONAL PURPOSES ONLY. VERIFICATION OF THE SPECIFIED DATA SHOULD BE MADE BY CONSULTING THE MOST RECENT JOINT HAZARD CLASSIFICATION SYSTEM LISTING OR OTHER APPROVED LISTING(S).

REVISION

REVISION NO. 1, DATED SEPTEMBER 1995, CONSISTS OF:

1. ADDING ITEM BY NATIONAL STOCK NUMBER (NSN) TO "PALLET UNIT DATA" CHART.

GENERAL NOTES

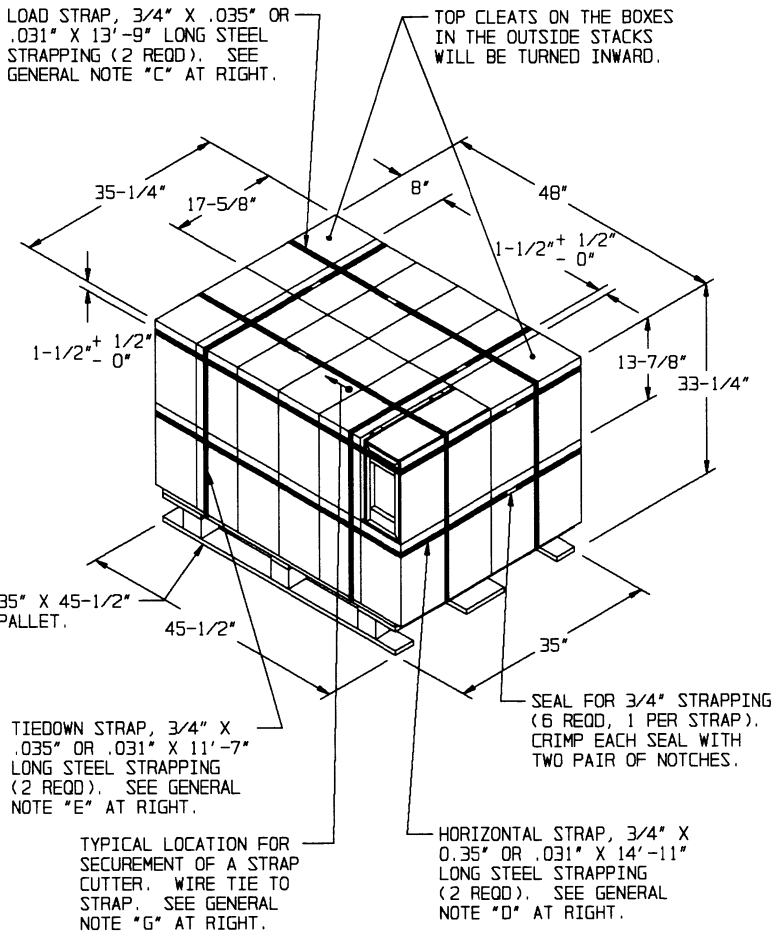

PALLET UNIT

SEE GENERAL NOTE "B" AT RIGHT.

24 BOXES OF DEMOLITION CHARGES (20 PER BOX) AT 53 LBS	--	1,272 LBS (APPROX)
DUNNAGE	-----	6 LBS
PALLET	-----	65 LBS

TOTAL WEIGHT	-----	1,343 LBS (APPROX)
CUBE	-----	32.6 CU FT (APPROX)

PALLET, 35" X 45-1/2"	---	1 REQD	-----	65 LBS	
STEEL STRAPPING, 3/4"	-	80.50'	REQD	-----	5.75 LBS
SEAL FOR 3/4" STRAPPING	-	6 REQD	-----	NIL	

- A. THIS APPENDIX CANNOT STAND ALONE BUT MUST BE USED IN CONJUNCTION WITH THE BASIC UNITIZATION PROCEDURES DRAWING 19-48-4116-20PA1002. TO PRODUCE AN APPROVED UNIT LOAD, ALL PERTINENT PROCEDURES, SPECIFICATIONS AND CRITERIA SET FORTH WITHIN THE BASIC DRAWING WILL APPLY TO THE PROCEDURES DELINEATED IN THIS APPENDIX. ANY EXCEPTIONS TO THE BASIC PROCEDURES ARE SPECIFIED IN THIS APPENDIX.
- B. DIMENSIONS, CUBE AND WEIGHT OF A PALLET UNIT WILL VARY SLIGHTLY DEPENDING UPON THE ACTUAL DIMENSIONS OF THE BOXES AND THE WEIGHT OF THE SPECIFIC ITEM BEING UNITIZED.
- C. THE LOAD STRAPS MAY BE THREADED THROUGH THE STRAP SLOTS OF A PALLET OR PRE-POSITIONED ON THE PALLET DECK PRIOR TO PLACING BOXES ON THE PALLET. LOAD STRAPS MUST BE TENSIONED AND SEALED PRIOR TO APPLICATION OF TIEDOWN STRAPS.
- D. INSTALL EACH HORIZONTAL STRAP TO ENCIRCLE A LAYER OF BOXES ON THE PALLET. NOTE THAT THE STRAPS WILL BE LOCATED AS SHOWN, NEAR THE TOP OF EACH LAYER. HORIZONTAL STRAPS MUST BE TENSIONED AND SEALED PRIOR TO THE APPLICATION OF TIEDOWN STRAPS.
- E. INSTALL EACH TIEDOWN STRAP TO PASS UNDER THE TOP DECK BOARDS OF THE PALLET. NOTE THAT THE STRAPS WILL BE LOCATED AS SHOWN, NEAR THE SIDE CLEATS OF THE END PANELS OF THE BOX. TIEDOWN STRAPS WILL NOT BE APPLIED UNTIL THE LOAD STRAPS HAVE BEEN TENSIONED AND SEALED.
- F. THE FOLLOWING AMC DRAWINGS ARE APPLICABLE FOR OUTLOADING AND STORAGE OF THE ITEMS COVERED BY THIS APPENDIX.
 - CARLOADING - - - - 19-48-4115-5PA1002
 - TRUCKLOADING - - - - 19-48-4117-11PA1003
 - STORAGE - - - - 19-48-4118-1-2-3-4-14-22PA1002
 - COMMERCIAL CONTAINER - - - - 19-48-4153-15PA1002
 - MILVAN - - - - 19-48-4166-15PA1003
 - SIDE OPENING COMMERCIAL CONTAINER - - - - 19-48-4267-15PA1009
- G. FOR METHOD OF SECURING A STRAP CUTTER TO THE PALLET UNIT, SEE AMC DRAWING 19-48-4127-20P1000.
- H. IF ITEMS COVERED HEREIN ARE UNITIZED PRIOR TO ISSUANCE OF THIS APPENDIX, THE BOXES NEED NOT BE REUNITIZED SOLELY TO CONFORM TO THIS APPENDIX.
- J. THE UNITIZATION PROCEDURES DEPICTED HEREIN MAY ALSO BE USED FOR UNITIZING DEMOLITION CHARGES WHEN IDENTIFIED BY DIFFERENT NATIONAL STOCK NUMBERS (NSN) THAN WHAT IS SHOWN ON PAGE 2, PROVIDED THE BOX PACK DOES NOT VARY FROM WHAT IS DELINEATED HEREIN. THE EXPLOSIVE CLASSIFICATION OF OTHER ITEMS MAY BE DIFFERENT THAN WHAT IS SHOWN.
- K. THE STYLE 1A PALLET DELINEATED IN THE DETAIL AT LEFT NEED NOT HAVE CHAMFERS OR STRAP SLOTS AS SPECIFIED WITHIN MILITARY SPECIFICATION MIL-P-15011 WHEN USED FOR THE UNITIZATION OF ITEMS COVERED BY THIS APPENDIX.

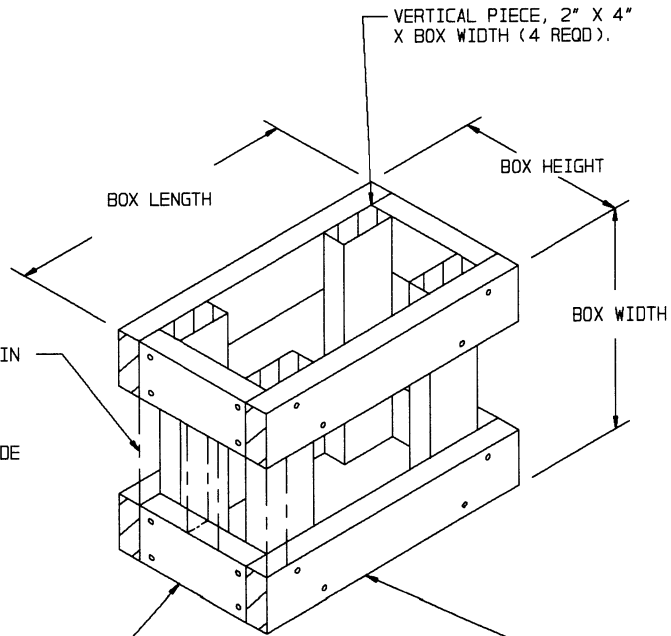

SUPPORT PIECE, 2" X 4" X CUT-TO-FIT IN LENGTH (AS REQD). NAIL TO VERTICAL PIECE W/2-10d NAILS. NOTE: WHEN A UNIT HAS MORE THAN EIGHT (8) BOXES OMITTED, THE FILLER ASSEMBLY OR ASSEMBLIES LOCATED ON THE 45-1/2" SIDE OR SIDES OF THE PALLET WILL REQUIRE SUPPORT PIECES AS SHOWN.

LATERAL PIECE, 2" X 4" X BOX HEIGHT MINUS 3" (4 REQD). NAIL TO VERTICAL PIECES W/2-10d NAILS AT EACH END.

LONGITUDINAL PIECE, 2" X 4" X BOX LENGTH (4 REQD). NAIL TO VERTICAL PIECES W/2-10d NAILS AT EACH END.

FILLER ASSEMBLY
(FOR MINUS ONE BOX)