

APPENDIX I20D

UNITIZATION PROCEDURES FOR BOXED AMMUNITION AND COMPONENTS ON 4-WAY ENTRY PALLETS

CHARGE, DEMOLITION, SHAPED, PACKED 1 PER
WOODEN BOX, UNITIZED 24 BOXES PER 40"
X 48" PALLET; APPROX BOX SIZE 20 $\frac{1}{2}$ " L X
11 $\frac{5}{8}$ " W X 13 $\frac{1}{8}$ " H

PALLET UNIT DATA						
ITEMS INCLUDED		HAZARD CLASSIFICATION ①				WEIGHT (LBS)
NSN	DODIC	DOT CLASS	CG CLASS	QD CLASS	COMP GROUP	
1375- 00-088-6691	M421	A	IX-B	1.1	D	1,647
00-028-5241	M421	A	IX-B	1.1	D	1,647

REVISION

REVISION NO. 1, DATED NOVEMBER 1985, CONSISTS OF:

1. CHANGING BOX DIMENSIONS.
2. UPDATING DRAWING FORMAT.

NOTICE: THIS APPENDIX CANNOT STAND ALONE BUT MUST
BE USED IN CONJUNCTION WITH THE BASIC UNITIZATION
PROCEDURES DRAWING 19-48-4116-20PA1002.

① HAZARD CLASSIFICATION DATA CONTAINED IN THE ABOVE CHART IS FOR GUIDANCE AND INFORMATIONAL PURPOSES ONLY. VERIFICATION OF THE SPECIFIED DATA SHOULD BE MADE BY CONSULTING THE MOST RECENT JOINT HAZARD CLASSIFICATION SYSTEM LISTING OR OTHER APPROVED LISTING (S).

DO NOT SCALE

REVISIONS				DRAWN BY <i>AL/MSK</i>	PROJ. ENG. <i>707/MSW</i>
1	NOV 85	<i>WRF</i>	<i>William Ernst</i>	<i>RST</i>	<i>John Boyd</i>
APPROVED, U. S. ARMY ARMAMENT MATERIEL READINESS COMMAND					
<i>Lawrence Kuetz</i> <i>Donald P. Feltz</i>					
APPROVED BY ORDER OF COMMANDING GENERAL, U. S. ARMY MATERIEL DEVELOPMENT AND READINESS COMMAND (DARCOM)					
<i>Stephen T. Boyd Jr.</i>					
U. S. ARMY REPERE AMMUNITION CENTER AND SCHOOL					
U. S. ARMY DARCOM DRAWING					
AUGUST 1979					
CLASS	DIVISION	DRAWING	FILE		
19	48	4116/ I20D	20PA 1002		

LOAD STRAP, 3/4" X .035" OR .031" X 15'-8"
LONG STEEL STRAPPING (2 REQD). SEE
GENERAL NOTE "C"
AT RIGHT.

TIEDOWN STRAP, 3/4" X .035" OR .031" X
13'-9" LONG STEEL STRAPPING (4 REQD).
SEE GENERAL NOTE "D" AT RIGHT.

GENERAL NOTES

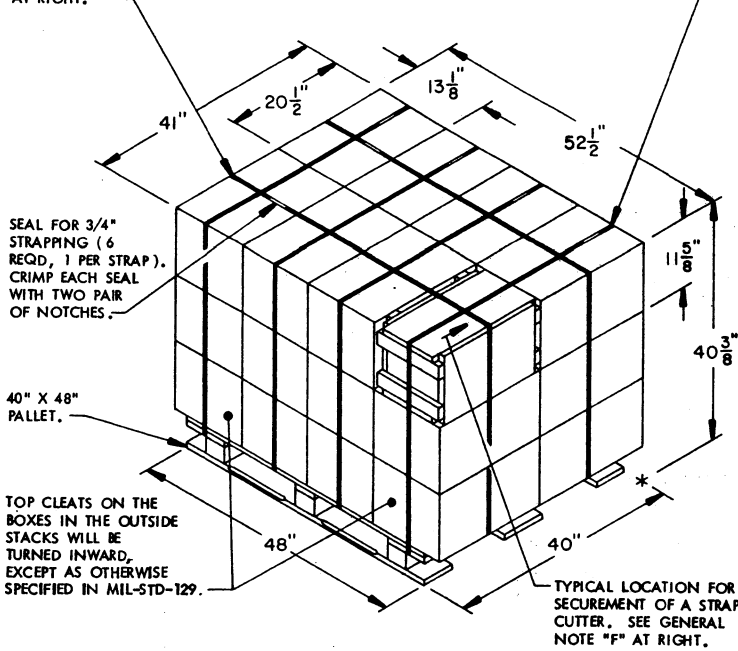

PALLET UNIT

SEE GENERAL NOTE "B" AT RIGHT.

24 BOXES OF DEMOLITION CHARGE (1 PER BOX) @ 65 LBS	-----	1,560 LBS (APPROX)
DUNNAGE	-----	7 LBS
PALLET	-----	80 LBS
TOTAL WEIGHT	-----	1,647 LBS (APPROX)
CUBE	-----	50.3 CU FT (APPROX)

- THIS APPENDIX CANNOT STAND ALONE BUT MUST BE USED IN CONJUNCTION WITH THE BASIC UNITIZATION PROCEDURES DRAWING 19-48-4116-20PA1002. TO PRODUCE AN APPROVED UNIT LOAD, ALL PERTINENT PROCEDURES, SPECIFICATIONS AND CRITERIA SET FORTH WITHIN THE BASIC DRAWING WILL APPLY TO THE PROCEDURES DELINEATED IN THIS APPENDIX. ANY EXCEPTIONS TO THE BASIC PROCEDURES ARE SPECIFIED IN THIS APPENDIX.
- DIMENSIONS, CUBE AND WEIGHT OF A PALLET UNIT WILL VARY SLIGHTLY DEPENDING UPON THE ACTUAL DIMENSIONS OF THE BOXES AND THE WEIGHT OF THE SPECIFIC ITEM BEING UNITIZED.
- THE LOAD STRAPS MAY BE THREADED THROUGH THE STRAP SLOTS OF A PALLET OR PRE-POSITIONED ON THE PALLET DECK PRIOR TO PLACING BOXES ON THE PALLET. LOAD STRAPS MUST BE TENSIONED AND SEALED PRIOR TO APPLICATION OF TIEDOWN STRAPS.
- INSTALL EACH TIEDOWN STRAP TO PASS UNDER THE DECK/STRINGER BOARDS OF THE PALLET AND TO BE LOCATED AS SHOWN. TIEDOWN STRAPS WILL NOT BE APPLIED UNTIL THE LOAD STRAPS HAVE BEEN TENSIONED AND SEALED.
- THE FOLLOWING AMC (DARCOM) DRAWINGS ARE APPLICABLE FOR OUT-LOADING AND STORAGE OF THE ITEMS COVERED BY THIS APPENDIX.

CARLOADING -----	DRAWING 19-48-4115-5PA1002
TRUCKLOADING -----	DRAWING 19-48-4117-11PA1003
STORAGE -----	DRAWING 19-48-4118-1-2-3-4-14-22 PA1002
- FOR METHOD OF SECURING A STRAP CUTTER TO THE PALLET UNIT, SEE DARCOM DRAWING 19-48-4127-20P1000.
- IF ITEMS COVERED HEREIN ARE UNITIZED PRIOR TO ISSUANCE OF THIS APPENDIX, THE BOXES NEED NOT BE REUNITIZED SOLELY TO CONFORM TO THIS APPENDIX.
- THE UNITIZATION PROCEDURES DEPICTED HEREIN MAY ALSO BE USED FOR UNITIZING DEMOLITION CHARGES WHEN IDENTIFIED BY DIFFERENT NATIONAL STOCK NUMBERS (NSN) THAN WHAT IS SHOWN ON THE TITLE PAGE, PROVIDED THE BOX PACK DOES NOT VARY FROM WHAT IS DELINEATED HEREIN. THE EXPLOSIVE CLASSIFICATION OF OTHER ITEMS MAY BE DIFFERENT THAN WHAT IS SHOWN.
- THE STYLE 1 PALLET DELINEATED IN THE DETAIL AT LEFT NEED NOT HAVE CHAMFERS OR STRAP SLOTS AS SPECIFIED WITHIN MILITARY SPECIFICATION MIL-P-15011 WHEN USED FOR THE UNITIZATION OF THE ITEMS COVERED BY THIS APPENDIX. IF THE PALLET TO BE USED DOES NOT HAVE STRAP SLOTS, HOWEVER, THE LOAD STRAPS MUST BE PRE-POSITIONED ON THE PALLET DECK PRIOR TO PLACING THE BOXES ON THE PALLET.

BILL OF MATERIAL

PALLET, 40" X 48" -----	1 REQD -----	80 LBS
STEEL STRAPPING, 3/4" -----	86.33' REQD -----	6.17 LBS
SEAL FOR 3/4" STRAPPING -----	6 REQD -----	NIL

