

APPENDIX 120B

UNITIZATION PROCEDURES FOR BOXED AMMUNITION AND COMPONENTS ON 4-WAY ENTRY PALLETS

CHARGE, DEMOLITION, BLOCK, PACKED 192 PER
WOODEN BOX, UNITIZED 24 BOXES PER 35" X 45½"
PALLET; APPROX BOX SIZE 18" L X 16⅝" W X 9¾" H

PALLET UNIT DATA						
ITEMS INCLUDED		HAZARD CLASSIFICATION				WEIGHT
NSN	DODIC	DOT CLASS	CG CLASS	QD CLASS	COMP GROUP	(LBS)
1375- 00-590-1377 00-926-9394	MCB0	A	IX-B	1.1	D	2,087
	MCB0	A	IX-B	1.1	D	2,087

NOTICE: THIS APPENDIX CANNOT STAND ALONE BUT MUST BE USED IN CONJUNCTION WITH THE BASIC UNITIZATION PROCEDURES DRAWING 19-48-4116-20PA1002.

REVISIONS				DRAFTSMAN <i>PJB/mek</i>	PROJ ENG <i>WJW</i>
				CHECKER <i>RSH</i>	LOC ENGRS OFFICE <i>Jeh</i>
APPROVED, U. S. ARMY ARMAMENT MATERIEL READINESS COMMAND					
<i>William E. Ernst</i>					
DRBAR-LEP			DRBAR-TMD		
APPROVED BY ORDER OF COMMANDING GENERAL, U. S. ARMY MATERIEL DEVELOPMENT AND READINESS COMMAND (DARCOM)					
<i>William E. Ernst</i>					
U. S. ARMY DARCOM DRAWING					
MARCH 1983					
CLASS	DIVISION	DRAWING	FILE		
19	48	4116/ 120B	20PA 1002		

DO NOT SCALE

GENERAL NOTES

- A. THIS APPENDIX CANNOT STAND ALONE BUT MUST BE USED IN CONJUNCTION WITH THE BASIC UNITIZATION PROCEDURES DRAWING 19-48-4116-20PA1002. TO PRODUCE AN APPROVED UNIT LOAD, ALL PERTINENT PROCEDURES, SPECIFICATIONS AND CRITERIA SET FORTH WITHIN THE BASIC DRAWING WILL APPLY TO THE PROCEDURES DELINEATED IN THIS APPENDIX. ANY EXCEPTIONS TO THE BASIC PROCEDURES ARE SPECIFIED IN THIS APPENDIX.
- B. DIMENSIONS, CUBE AND WEIGHT OF A PALLET UNIT WILL VARY SLIGHTLY DEPENDING UPON THE ACTUAL DIMENSIONS OF THE BOXES AND THE WEIGHT OF THE SPECIFIC ITEM BEING UNITIZED.
- C. THE LOAD STRAPS MAY BE INSTALLED THROUGH THE STRAP SLOTS OF A PALLET OR PRE-POSITIONED ON THE PALLET DECK PRIOR TO PLACING BOXES ON THE PALLET. LOAD STRAPS MUST BE TENSIONED AND SEALED PRIOR TO APPLICATION OF TIEDOWN STRAPS.
- D. INSTALL EACH TIEDOWN STRAP TO PASS UNDER THE TOP DECK BOARDS OF THE PALLET AND TO BE LOCATED AS SHOWN. TIEDOWN STRAPS WILL NOT BE APPLIED UNTIL THE LOAD STRAPS HAVE BEEN TENSIONED AND SEALED.
- E. THE FOLLOWING DARCOM DRAWINGS ARE APPLICABLE FOR OUT-LOADING AND STORAGE OF THE ITEMS COVERED BY THIS APPENDIX.
 CARLOADING-----DRAWING 19-48-4115-5PA1002
 TRUCKLOADING-----DRAWING 19-48-4117-11PA1003
 STORAGE-----DRAWING 19-48-4118-1-2-3-4-14-22PA1002
- F. FOR METHOD OF SECURING A STRAP CUTTER TO THE PALLET UNIT, SEE DARCOM DRAWING 19-48-4127-20P1000.
- G. IF ITEMS COVERED HEREIN ARE UNITIZED PRIOR TO ISSUANCE OF THIS APPENDIX, THE BOXES NEED NOT BE REUNITIZED SOLELY TO CONFORM TO THIS APPENDIX.
- H. THE UNITIZATION PROCEDURES DEPICTED HEREIN MAY ALSO BE USED FOR UNITIZING DEMOLITION CHARGES WHEN IDENTIFIED BY DIFFERENT NATIONAL STOCK NUMBERS (NSN) THAN WHAT IS SHOWN ON THE TITLE PAGE, PROVIDED THE BOX PACK DOES NOT VARY FROM WHAT IS DELINEATED HEREIN. THE EXPLOSIVE CLASSIFICATION OF OTHER ITEMS MAY BE DIFFERENT THAN WHAT IS SHOWN.
- J. WHEN THE UNIT LOAD DEPICTED AT LEFT IS TO BE USED FOR UNITIZING MARINE CORPS AMMUNITION, ONE LAYER OF BOXES MUST BE OMITTED, TIEDOWN STRAP LENGTHS MUST BE DECREASED TO 12'-0", AND LOAD STRAP LENGTHS MUST BE DECREASED TO 14'-4". THIS WILL RESULT IN AN OVERALL UNIT HEIGHT OF 34'-3/4", A GROSS WEIGHT OF 1,582 POUNDS, AND A UNIT CUBE OF 36.1 CUBIC FEET. ADDITIONALLY, THE UNIT LOAD MAY BE MODIFIED AS DESCRIBED WHEN BEING SHIPPED BY MILVAN OR COMMERCIAL INTERMODAL FREIGHT CONTAINER, CONVENTIONAL VAN TRAILER OR CONVENTIONAL OR HIGH-CAPACITY BOXCAR. THE DETERMINATION TO REDUCE THE LOAD BY A LAYER FOR TRANSPORTATION WILL BE MADE BY THE RESPONSIBLE COMMAND AND WILL BE BASED UPON ECONOMICS OF TRANSPORTATION AND HANDLING.

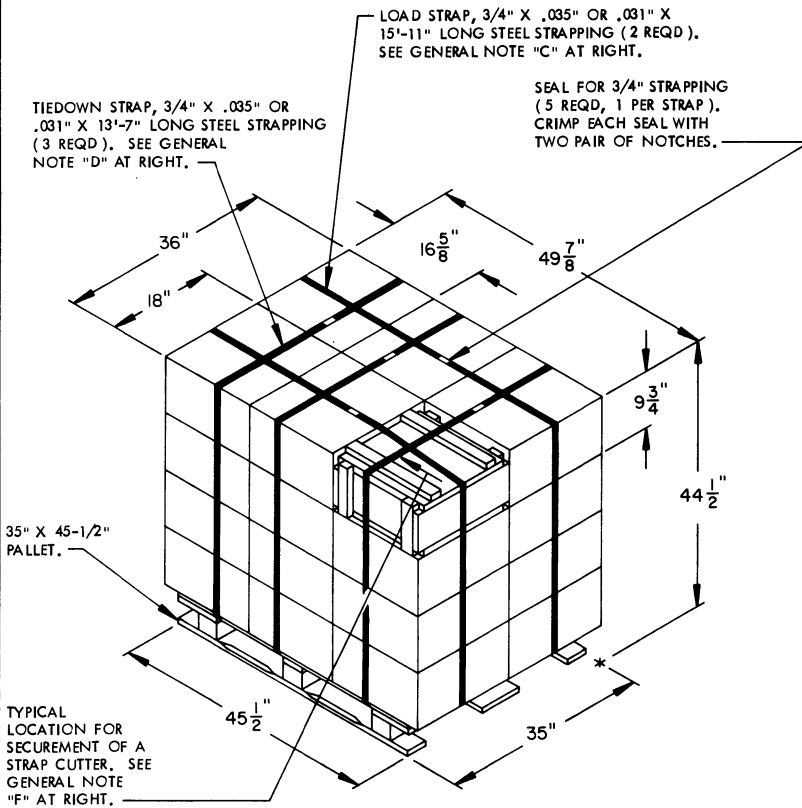

PALLET UNIT

SEE GENERAL NOTE "B" AT RIGHT.

24 BOXES OF CHARGE, DEMOLITION (192 PER BOX) @ 84 LBS -----	2,016 LBS (APPROX)
DUNNAGE -----	6 LBS
PALLET -----	65 LBS
TOTAL WEIGHT-----	2,087 LBS (APPROX)
CUBE-----	46.2 CUBIC FEET (APPROX)

BILL OF MATERIAL		
PALLET, 35" X 45-1/2" -----	1 REQD-----	65 LBS
STEEL STRAPPING, 3/4" -----	72.58' REQD-----	5.18 LBS
SEAL FOR 3/4" STRAPPING-----	5 REQD-----	NIL

