

APPENDIX 120A

UNITIZATION PROCEDURES FOR BOXED AMMUNITION AND COMPONENTS ON 4-WAY ENTRY PALLETS

CHARGE, DEMOLITION, BLOCK, PACKED 30 PER
WIREBOUND BOX, UNITIZED 54 BOXES PER 40"
X 48" PALLET; APPROX BOX SIZE 13-3/4" L X
11-9/16" W X 8" H

NOTICE: THIS APPENDIX CANNOT STAND ALONE BUT MUST BE USED IN CONJUNCTION WITH
THE BASIC UNITIZATION PROCEDURES DRAWING 19-48-4116-20PA1002.

DISTRIBUTION STATEMENT A.

APPROVED FOR PUBLIC RELEASE:
DISTRIBUTION IS UNLIMITED.

U. S. ARMY MATERIEL COMMAND DRAWING			
APPROVED, U. S. ARMY INDUSTRIAL OPERATIONS COMMAND <i>NLM</i> <i>David W. Peterson</i> AMSTA-AR-ESK	DRAFTSMAN BETTY J. KUNDERT ENGINEER SANDRA M. SCHULTZ		
<i>David E. Steinhilber</i> AMSIO-TMJ	SUPPLY ENGINEERING DIVISION <i>T. J. Muehle</i>	TRANSPORTATION ENGINEERING DIVISION <i>W. J. Smith</i>	VALIDATION ENGINEERING DIVISION <i>J. K. Keenan</i>
APPROVED BY ORDER OF COMMANDING GENERAL, U. S. ARMY MATERIEL COMMAND <i>Terry V. Doolledge</i> DEFENSE AMMUNITION CENTER	LOGISTICS ENGINEERING OFFICE <i>William F. Ernst</i> JANUARY 1981		
REVISION NO. 3	OCTOBER 1996	CLASS 19	DIVISION 48
SEE THE REVISION LISTING ON PAGE 2		DRAWING 4116/ 120A	FILE 20PA 1002

DO NOT SCALE

PALLET UNIT DATA				
ITEMS INCLUDED		HAZARD CLASS AND DIVISION ●		APPROX WEIGHT LBS
NSN	DODIC	OD CLASS	COMP GROUP	
1375-00-724-7040	MO23	1.1	D	2,630
01-389-3854	MO23	1.1	D	2,630

- HAZARD CLASSIFICATION DATA CONTAINED IN THE ABOVE CHART IS FOR GUIDANCE AND INFORMATIONAL PURPOSES ONLY. VERIFICATION OF THE SPECIFIED DATA SHOULD BE MADE BY CONSULTING THE MOST RECENT JOINT HAZARD CLASSIFICATION SYSTEM LISTING OR OTHER APPROVED LISTING(S).

REVISIONS

REVISION NO. 1, DATED JUNE 1985, CONSISTS OF:

1. CHANGING BOX DIMENSIONS.
2. UPDATING PALLET UNIT TO CONFORM TO 1 ABOVE.

REVISION NO. 2, DATED SEPTEMBER 1995, CONSISTS OF:

1. ADDING ITEM BY NATIONAL STOCK NUMBER TO "PALLET UNIT DATA" CHART.

REVISION NO. 3, DATED OCTOBER 1996 CONSISTS OF:

1. CHANGING HEIGHT OF BOX
2. UPDATING THE PALLET TO CONFORM TO NO. 1 ABOVE.
3. ADDING THE PACKAGE REFERENCE TO GENERAL NOTES.
4. DELETING SPACER ASSEMBLY.

GENERAL NOTES

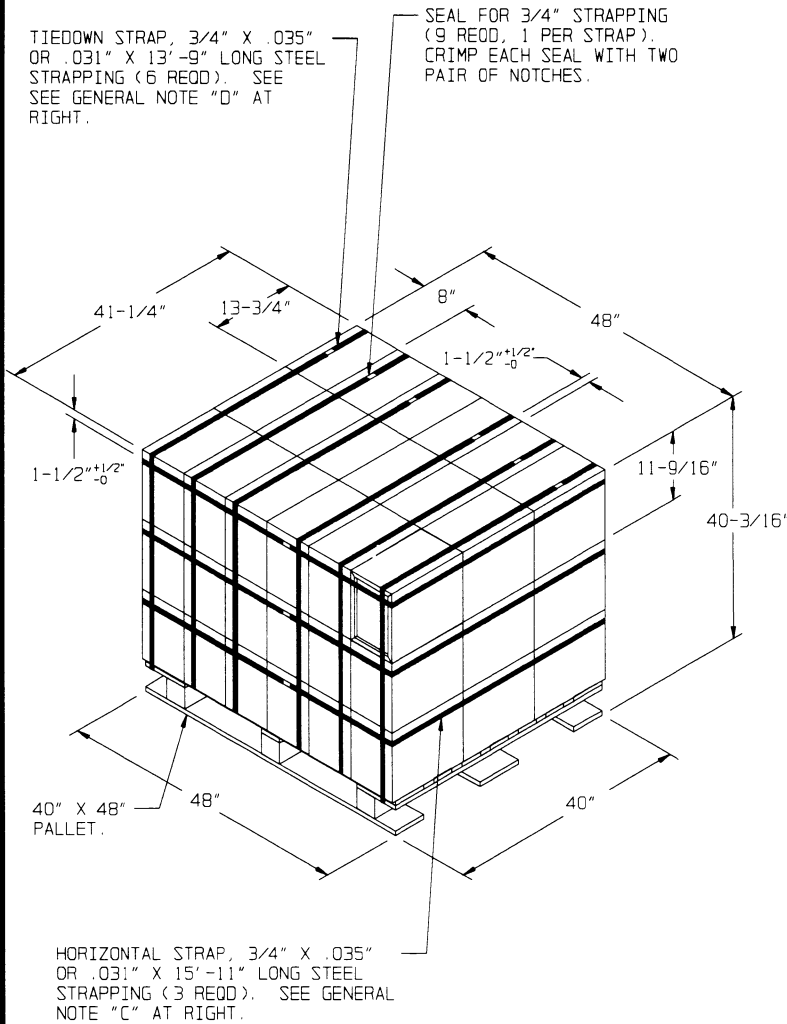

PALLET UNIT

SEE GENERAL NOTE "B" AT RIGHT.

54 BOXES OF DEMOLITION CHARGE (30 PER BOX) AT 47 LBS	--	2,538 LBS (APPROX)
DUNNAGE	-----	12 LBS
PALLET	-----	80 LBS

TOTAL WEIGHT	-----	2,630 LBS (APPROX)
CUBE	-----	46.0 CU FT (APPROX)

BILL OF MATERIAL

PALLET, 40" X 48"	-----	1 REOD	-----	80 LBS
STEEL STRAPPING, 3/4"	-----	130.25' REOD	-----	11.63 LBS
SEAL FOR 3/4" STRAPPING	-----	9 REOD	-----	NIL

- A. THIS APPENDIX CANNOT STAND ALONE BUT MUST BE USED IN CONJUNCTION WITH THE BASIC UNITIZATION PROCEDURES DRAWING 19-48-4116-20PA1002. TO PRODUCE AN APPROVED UNIT LOAD, ALL PERTINENT PROCEDURES, SPECIFICATIONS AND CRITERIA SET FORTH WITHIN THE BASIC DRAWING WILL APPLY TO THE PROCEDURES DELINEATED IN THIS APPENDIX. ANY EXCEPTIONS TO THE BASIC PROCEDURES ARE SPECIFIED IN THIS APPENDIX.
- B. DIMENSIONS, CUBE AND WEIGHT OF A PALLET UNIT WILL VARY SLIGHTLY DEPENDING UPON THE ACTUAL DIMENSIONS OF THE BOXES AND THE WEIGHT OF THE SPECIFIC ITEM BEING UNITIZED.
- C. INSTALL EACH HORIZONTAL STRAP TO ENCIRCLE A LAYER OF BOXES ON THE PALLET. NOTE THAT THE STRAPS WILL BE LOCATED AS DIMENSIONED, NEAR THE TOP OF EACH LAYER. HORIZONTAL STRAPS MUST BE TENSIONED AND SEALED PRIOR TO APPLICATION OF TIEDOWN STRAPS.
- D. INSTALL EACH TIEDOWN STRAP TO PASS UNDER THE DECK/ STRINGER BOARDS OF THE PALLET. NOTE THAT THE STRAPS WILL BE LOCATED AS DIMENSIONED, NEAR THE SIDE CLEATS OF THE END PANELS OF THE BOX. TIEDOWN STRAPS WILL NOT BE APPLIED UNTIL THE HORIZONTAL STRAPS HAVE BEEN TENSIONED AND SEALED.
- E. THE FOLLOWING AMC DRAWINGS ARE APPLICABLE FOR OUTLOADING AND STORAGE OF THE ITEMS COVERED BY THIS APPENDIX.
 - CARLOADING - - - - 19-48-4115-5PA1002
 - TRUCKLOADING - - - 19-48-4117-11PA1003
 - STORAGE - - - - - 19-48-4118-1-2-3-4-14-22PA1002
 - END OPENING ISO CONTAINER - - - - 19-48-4153-15PA1002
 - MILVAN - - - - - 19-48-4166-15PA1003
 - SIDE OPENING ISO CONTAINER - - - - 19-48-4267-15PA1009
- F. IF ITEMS COVERED HEREIN ARE UNITIZED PRIOR TO ISSUANCE OF THIS APPENDIX, THE BOXES NEED NOT BE REUNITIZED SOLELY TO CONFORM TO THIS APPENDIX.
- G. THE UNITIZATION PROCEDURES DEPICTED HEREIN MAY ALSO BE USED FOR UNITIZING DEMOLITION CHARGES WHEN IDENTIFIED BY DIFFERENT NATIONAL STOCK NUMBERS (NSN) THAN WHAT IS SHOWN ON PAGE 2, PROVIDED THE BOX PACK DOES NOT VARY FROM WHAT IS DELINEATED HEREIN. THE EXPLOSIVE CLASSIFICATION OF OTHER ITEMS MAY BE DIFFERENT THAN WHAT IS SHOWN.
- H. THE STYLE 1 PALLET DELINEATED IN THE DETAIL AT LEFT NEED NOT HAVE CHAMFERS OR STRAP SLOTS AS SPECIFIED WITHIN MILITARY SPECIFICATION MIL-P-15011 WHEN USED FOR THE UNITIZATION OF THE ITEMS COVERED BY THIS APPENDIX.
- J. DIMENSIONS ARE APPROXIMATE AND MAY REQUIRE ADJUSTMENTS FOR THE LENGTH AND HEIGHT DEPENDING UPON THE OVERALL BOX DIMENSION. (SEE BASIC PROCEDURES).
- K. FOR DETAILS OF THE WIREBOUND BOX SEE 8876127.

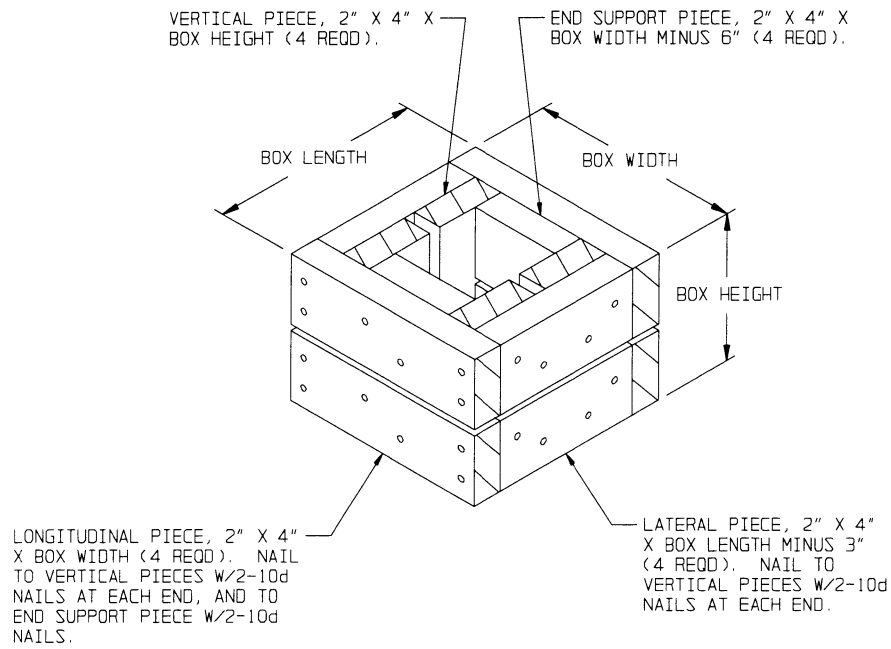

FILLER ASSEMBLY

(FOR MINUS ONE BOX)