

APPENDIX 120

UNITIZATION PROCEDURES FOR BOXED AMMUNITION AND COMPONENTS ON 4-WAY ENTRY PALLETS

CHARGE, DEMOLITION, BLOCK, PACKED VARIOUS
QUANTITIES PER WOODEN BOX, UNITIZED 24 BOXES PER
35" X 45½" PALLET; APPROX BOX SIZE 22½" L X 11¼" W X 9⅝" H

PALLET UNIT DATA						
ITEMS INCLUDED		HAZARD CLASSIFICATION				WEIGHT (LBS)
NSN	DODIC	DOT CLASS	CG CLASS	QD CLASS	COMP GROUP	
1375-						
00-028-5140	M031	A	IX-B	1.1	D	1,728
00-028-5142	M032	A	IX-B	1.1	D	1,776
00-926-9316	M031	A	IX-B	1.1	D	1,704
00-935-6139	M032	A	IX-B	1.1	D	1,788
00-028-5147	M034	A	IX-B	1.1	D	1,788

NOTE: THIS DRAWING SUPERCEDES DRAWING
19-48-4116/120C-20PA1002 DATED MAY 1980.

HAZARD CLASSIFICATION DATA CONTAINED IN THE ABOVE CHART IS FOR GUIDANCE AND INFORMATIONAL PURPOSES ONLY. VERIFICATION OF THE SPECIFIED DATA SHOULD BE MADE BY CONSULTING THE MOST RECENT JOINT HAZARD CLASSIFICATION SYSTEM LISTING OR OTHER APPROVED LISTING(S).

REVISIONS

REVISION NO. 1, DATED JANUARY 1978, CONSISTS OF:

1. CHANGING BOX DIMENSIONS.
2. ADDING SIX (6) MORE BOXES TO THE PALLET UNIT.
3. CHANGING UNITIZATION PROCEDURES TO CONFORM TO 1 AND 2 ABOVE.

REVISION NO. 2, DATED JULY 1984, CONSISTS OF:

1. ADDING ITEMS BY NATIONAL STOCK NUMBER TO "PALLET UNIT DATA" CHART.
2. ADDING SUPERSESSION NOTE.

NOTICE: THIS APPENDIX CANNOT STAND ALONE BUT MUST BE USED IN CONJUNCTION WITH THE BASIC UNITIZATION PROCEDURES DRAWING 19-48-4116-20PA1002.

REVISIONS				DRAFTSMAN AOK/mkx	PROJ ENG MWD/10m
1	JAN 78			9.8.78	
2	JUL 84				
APPROVED BY ORDER OF COMMANDING GENERAL, U. S. ARMY MATERIEL DEVELOPMENT AND READINESS COMMAND (DARCOM)					
DARCOM ARMO CENTER					
U. S. ARMY DARCOM DRAWING					
OCTOBER 1977					
CLASS	DIVISION	DRAWING	FILE		
19	48	4116/120	20PA 1002		

DO NOT SCALE

GENERAL NOTES

- A. THIS APPENDIX CANNOT STAND ALONE BUT MUST BE USED IN CONJUNCTION WITH THE BASIC UNITIZATION PROCEDURES DRAWING 19-48-4116-20PA1002. TO PRODUCE AN APPROVED UNIT LOAD, ALL PERTINENT PROCEDURES, SPECIFICATIONS AND CRITERIA SET FORTH WITHIN THE BASIC DRAWING WILL APPLY TO THE PROCEDURES DELINEATED IN THIS APPENDIX. ANY EXCEPTIONS TO THE BASIC PROCEDURES ARE SPECIFIED IN THIS APPENDIX.
- B. DIMENSIONS, CUBE AND WEIGHT OF A PALLET UNIT WILL VARY SLIGHTLY DEPENDING UPON THE ACTUAL DIMENSIONS OF THE BOXES AND THE WEIGHT OF THE SPECIFIC ITEM BEING UNITIZED.
- C. INSTALL EACH HORIZONTAL STRAP TO ENIRCLE A LAYER OF BOXES ON THE PALLET. HORIZONTAL STRAPS MUST BE TENSIONED AND SEALED PRIOR TO APPLICATION OF TIEDOWN STRAPS.
- D. INSTALL EACH TIEDOWN STRAP TO PASS UNDER THE TOP DECK BOARDS OF THE PALLET AND TO BE LOCATED AS SHOWN. TIEDOWN STRAPS WILL NOT BE APPLIED UNTIL THE HORIZONTAL STRAPS HAVE BEEN TENSIONED AND SEALED.
- E. THE FOLLOWING DARCOM DRAWINGS ARE APPLICABLE FOR OUTLOADING AND STORAGE OF THE ITEMS COVERED BY THIS APPENDIX.

CARLOADING -----	DRAWING 19-48-4115-5PA1002
TRUCKLOADING -----	DRAWING 19-48-4117-11PA1003
STORAGE -----	DRAWING 19-48-4118-1-2-3-4-14-22PA 1002
- F. FOR METHOD OF SECURING A STRAP CUTTER TO THE PALLET UNIT, SEE DARCOM DRAWING 19-48-4127-20P1000.
- G. IF ITEMS COVERED HEREIN ARE UNITIZED PRIOR TO ISSUANCE OF THIS APPENDIX, THE BOXES NEED NOT BE REUNITIZED SOLELY TO CONFORM TO THIS APPENDIX.
- H. THE UNITIZATION PROCEDURES DEPICTED HEREIN MAY ALSO BE USED FOR UNITIZING DEMOLITION CHARGES WHEN IDENTIFIED BY DIFFERENT NATIONAL STOCK NUMBERS (NSN) THAN WHAT IS SHOWN ON THE TITLE PAGE, PROVIDED THE BOX PACK DOES NOT VARY FROM WHAT IS DELINEATED HEREIN. THE EXPLOSIVE CLASSIFICATION OF OTHER ITEMS MAY BE DIFFERENT THAN WHAT IS SHOWN.

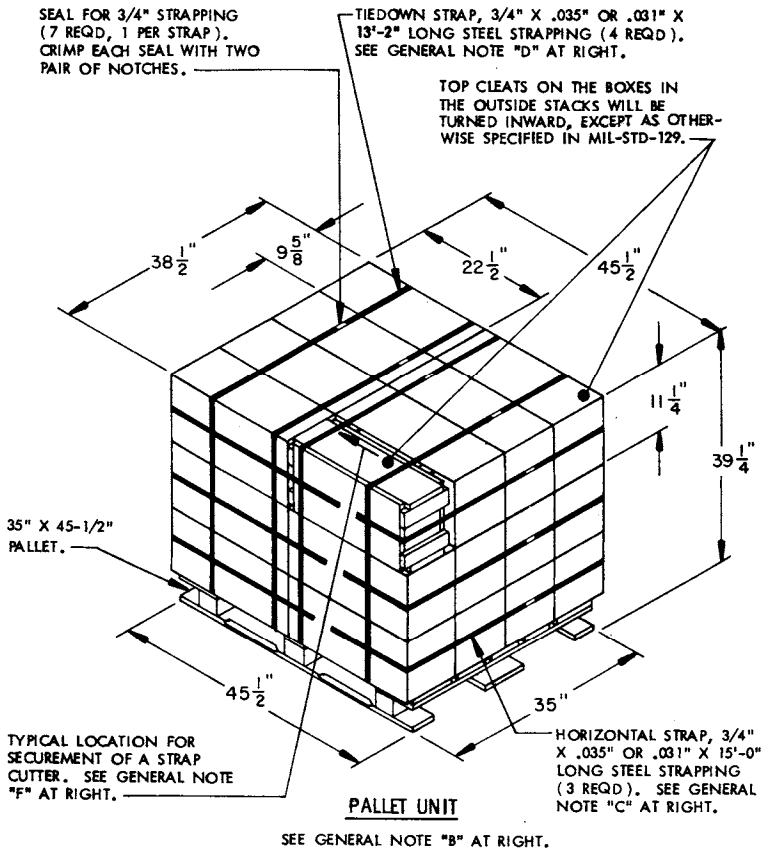

24 BOXES OF DEMOLITION CHARGE (48 PER BOX) @ 71.5 LBS -----	1,716 LBS (APPROX)
DUNNAGE -----	7 LBS
PALLET -----	65 LBS
TOTAL WEIGHT -----	1,788 LBS (APPROX)
CUBE -----	39.8 CU FT (APPROX)

BILL OF MATERIAL		
PALLET, 35" X 45-1/2" -----	1 REQD -----	65 LBS
STEEL STRAPPING, 3/4" -----	97.67' REQD -----	6.98 LBS
SEAL FOR 3/4" STRAPPING --	7 REQD -----	NIL

