

## APPENDIX 12

# UNITIZATION PROCEDURES FOR BOXED AMMUNITION AND COMPONENTS ON 4-WAY ENTRY PALLETS

CARTRIDGE, CALIBER .38, PACKED 1200 IN M2 SERIES  
METAL CONTAINERS, 2 PER WIREBOUND BOX, UNITIZED  
36 BOXES PER 40" X 48" PALLET; APPROX BOX  
SIZE 14½" L X 12¾" W X 8⅜" H

PALLET UNIT DATA						
ITEMS INCLUDED		HAZARD CLASSIFICATION <sup>①</sup>				WEIGHT (LBS)
NSN	DODIC	DOT CLASS	CG CLASS	QD CLASS	COMP GROUP	
1305- 00-322-6391	A400	C	I	1.4	S	3,401
00-123-0548	A404	C	I	1.4	S	3,537

① HAZARD CLASSIFICATION DATA CONTAINED IN THE ABOVE CHART IS FOR GUIDANCE AND INFORMATIONAL PURPOSES ONLY. VERIFICATION OF THE SPECIFIED DATA SHOULD BE MADE BY CONSULTING THE MOST RECENT JOINT HAZARD CLASSIFICATION SYSTEM LISTING OR OTHER APPROVED LISTING (S).

### REVISION

REVISION NO. 1, DATED JULY 1985, CONSISTS OF:

1. ADDING ALTERNATE LOAD STRAPS TO "PALLET UNIT" DRAWING.
2. ADDING GENERAL NOTES.
3. ADDING HAZARD CLASSIFICATION NOTE.

**NOTICE:** THIS APPENDIX CANNOT STAND ALONE BUT MUST BE USED IN CONJUNCTION WITH THE BASIC UNITIZATION PROCEDURES DRAWING 19-48-4116-20PA1002.

REVISIONS				DRAFTSMAN AGB/mk	PROJ ENG MWD/kew
1	JUL 85	WIRE W/STR	<i>William G. Smet</i>	CHIEF GRG/102-1	LOG ENGINE OFFICE <i>John Boyd</i>
				APPROVED, U. S. ARMY ARMAMENT MATERIEL READINESS COMMAND	
				DREAR - MAD <i>John W. Kuster</i> <i>Donald P. Feltus</i> DREAR - TMD	
				APPROVED BY ORDER OF COMMANDING GENERAL, U. S. ARMY MATERIEL DEVELOPMENT AND READINESS COMMAND (DARCOM) <i>John F. Boyd</i>	
				U. S. ARMY DEFENSE AMMUNITION CENTER AND SCHOOL	
				U. S. ARMY DARCOM DRAWING NOVEMBER 1979	
		CLASS	DIVISION	DRAWING	FILE
		19	48	4116/12	20PA 1002

DO NOT SCALE

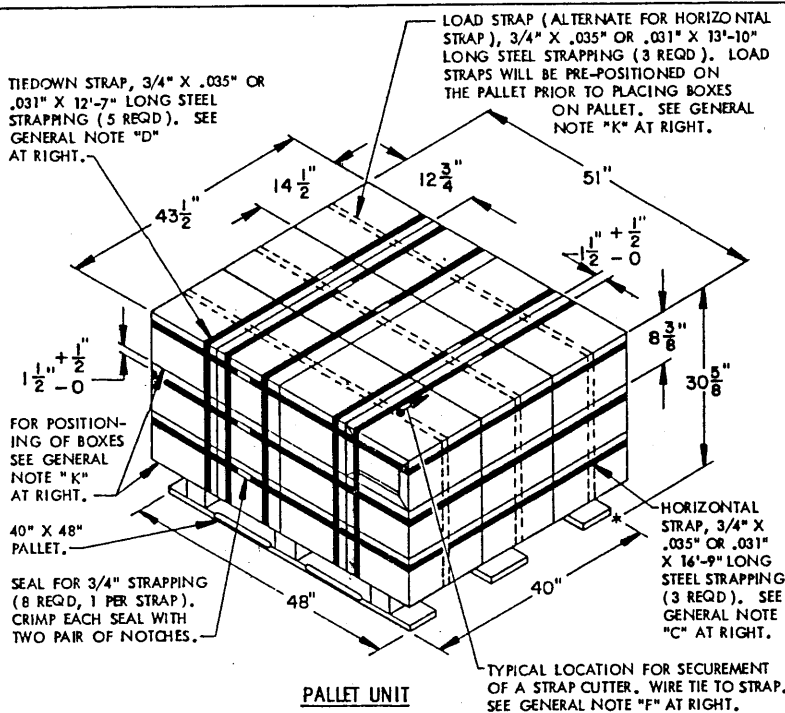

**PALLET UNIT**

SEE GENERAL NOTE "B" AT RIGHT.

36 BOXES OF .38 CALIBER CARTRIDGE (2400 PER BOX) @ 92 LBS	---	3,312 LBS (APPROX)
DUNNAGE	---	9 LBS
PALLET	---	80 LBS

TOTAL WEIGHT ----- 3,401 LBS (APPROX)

CUBE ----- 39.3 CU FT (APPROX)

**BILL OF MATERIAL**

PALLET, 40" X 48" -----	1 REQD -----	80 LBS
STEEL STRAPPING, 3/4" -----	113.17 REQD -----	8.08 LBS
SEAL FOR 3/4" STRAPPING --	8 REQD -----	NIL

**GENERAL NOTES**

- A. THIS APPENDIX CANNOT STAND ALONE BUT MUST BE USED IN CONJUNCTION WITH THE BASIC UNITIZATION PROCEDURES DRAWING 19-48-4116-20PA1002. TO PRODUCE AN APPROVED UNIT LOAD, ALL PERTINENT PROCEDURES, SPECIFICATIONS AND CRITERIA SET FORTH WITHIN THE BASIC DRAWING WILL APPLY TO THE PROCEDURES DELINEATED IN THIS APPENDIX. ANY EXCEPTIONS TO THE BASIC PROCEDURES ARE SPECIFIED IN THIS APPENDIX.
- B. DIMENSIONS, CUBE AND WEIGHT OF A PALLET UNIT WILL VARY SLIGHTLY DEPENDING UPON THE ACTUAL DIMENSIONS OF THE BOXES AND THE WEIGHT OF THE SPECIFIC ITEM BEING UNITIZED.
- C. INSTALL EACH HORIZONTAL STRAP TO ENIRCLE EACH LAYER OF BOXES ON THE PALLET. NOTE THAT THE STRAPS WILL BE LOCATED AS DIMENSIONED, NEAR THE TOP OF EACH LAYER. HORIZONTAL STRAPS MUST BE TENSIONED AND SEALED PRIOR TO APPLICATION OF TIEDOWN STRAPS.
- D. INSTALL EACH TIEDOWN STRAP TO PASS UNDER THE TOP DECK BOARDS OF THE PALLET. NOTE THAT THE STRAPS WILL BE LOCATED AS DIMENSIONED. TIEDOWN STRAPS WILL NOT BE APPLIED UNTIL THE HORIZONTAL STRAPS HAVE BEEN TENSIONED AND SEALED.
- E. THE FOLLOWING AMC (DARCOM) DRAWINGS ARE APPLICABLE FOR OUTLOADING AND STORAGE OF THE ITEMS COVERED BY THIS APPENDIX.  
 CARLOADING ----- DRAWING 19-48-4115-5PA1002  
 TRUCKLOADING --- DRAWING 19-48-4117-11PA1003  
 STORAGE '----- DRAWING 19-48-4118-1-2-3-4-14-22PA1002.
- F. FOR METHOD OF SECURING A STRAP CUTTER TO THE PALLET UNIT, SEE DARCOM DRAWING 19-48-4127-20P1000.
- G. IF ITEMS COVERED HEREIN ARE UNITIZED PRIOR TO ISSUANCE OF THIS APPENDIX, THE BOXES NEED NOT BE REUNITIZED SOLELY TO CONFORM TO THIS APPENDIX.
- H. THE UNITIZATION PROCEDURES DEPICTED HEREIN MAY ALSO BE USED FOR UNITIZING .38 CALIBER CARTRIDGES WHEN IDENTIFIED BY DIFFERENT NATIONAL STOCK NUMBER(S) (NSN) THAN WHAT IS SHOWN ON THE TITLE PAGE, PROVIDED THE BOX PACK DOES NOT VARY FROM WHAT IS DELINEATED HEREIN. THE EXPLOSIVE CLASSIFICATION OF OTHER ITEMS MAY BE DIFFERENT THAN WHAT IS SHOWN.
- J. THE STYLE 1 PALLET DELINEATED IN THE DETAIL AT LEFT NEED NOT HAVE CHAMFERS OR STRAP SLOTS AS SPECIFIED WITHIN MILITARY SPECIFICATION MIL-P-15011 WHEN USED FOR THE UNITIZATION OF THE ITEMS COVERED BY THIS APPENDIX.
- K. WHEN LOAD STRAPS ARE USED IN LIEU OF HORIZONTAL STRAPS IN THE UNIT LOAD AT LEFT, POSITION THE THREE OUTBOARD BOXES ON THE 40" SIDES OF THE BOTTOM LAYER OF THE UNIT WITH THE TOPS DOWNWARD, AND THE THREE OUTBOARD BOXES ON THE 40" SIDES OF THE TOP LAYER OF THE UNIT WITH TOPS UPWARD.

