

APPENDIX 115D

UNITIZATION PROCEDURES FOR BOXED AMMUNITION AND COMPONENTS ON 4-WAY ENTRY PALLETS

CHAFF, COUNTERMEASURE, XMI, PACKED 120 PER
WOODEN BOX, UNITIZED 16 BOXES PER 35" X
45½" PALLET; APPROX BOX SIZE 19½" L X 14" W
X 11½" H

PALLET UNIT DATA						
ITEMS INCLUDED		HAZARD CLASSIFICATION				WEIGHT (LBS)
NSN	DODIC	DOT CLASS	CG CLASS	QD CLASS	COMP GROUP	
UNASSIGNED		—	—	—	—	1,111

NOTICE: THIS APPENDIX CANNOT STAND ALONE BUT MUST
BE USED IN CONJUNCTION WITH THE BASIC UNITIZATION
PROCEDURES DRAWING 19-48-4116-20PA1002.

REVISIONS				PROJ. ENG. DEF/NEW								
				CHECKER: <i>RSB</i> U.S. ARMY OFFICE: <i>John Boyd</i>								
				APPROVED, U. S. ARMY ARMAMENT MATERIAL READINESS COMMAND DRAWER - 202 APPROVED BY ORDER OF COMMANDING GENERAL, U. S. ARMY MATERIAL DEVELOPMENT AND READINESS COMMAND (DARCOM) U.S. ARMY DEPOT AMMUNITION CENTER AND SCHOOL								
				U. S. ARMY DARCOM DRAWING OCTOBER 1979								
				<table border="1" style="width: 100%; border-collapse: collapse;"> <tr> <th style="width: 25%;">CLASS</th> <th style="width: 25%;">DIVISION</th> <th style="width: 25%;">DRAWING</th> <th style="width: 25%;">FILE</th> </tr> <tr> <td style="text-align: center;">19</td> <td style="text-align: center;">48</td> <td style="text-align: center;">4116/ 115D</td> <td style="text-align: center;">20PA 1002</td> </tr> </table>	CLASS	DIVISION	DRAWING	FILE	19	48	4116/ 115D	20PA 1002
CLASS	DIVISION	DRAWING	FILE									
19	48	4116/ 115D	20PA 1002									

DO NOT SCALE

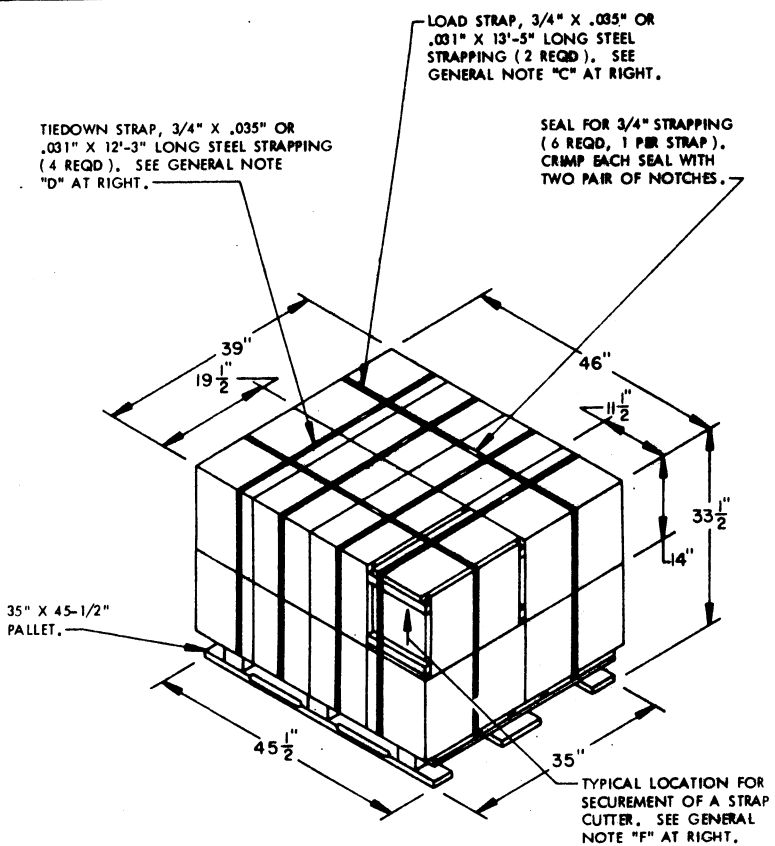

PALLET UNIT

SEE GENERAL NOTE "B" AT RIGHT.

16 BOXES OF C'AFF (120 PER BOX) @ 65 LBS -----	1,040 LBS (APPROX)
DUNNAGE -----	6 LBS
PALLET -----	65 LBS
TOTAL WEIGHT -----	1,111 LBS (APPROX)
CUBE -----	34,8 CU FT (APPROX)

BILL OF MATERIAL

PALLET, 35" X 45-1/2" -----	1 REQD -----	65 LBS
STEEL STRAPPING, 3/4" -----	75,83' REQD -----	5,42 LBS
SEAL FOR 3/4" STRAPPING -----	6 REQD -----	NIL

TIE PIECE, 1" X 4" X BOX HEIGHT (2 REQD). NAIL TO LONGITUDINAL PIECES W/1-6d NAIL AT EACH END AND TO LATERAL PIECE W/3-6d NAILS.

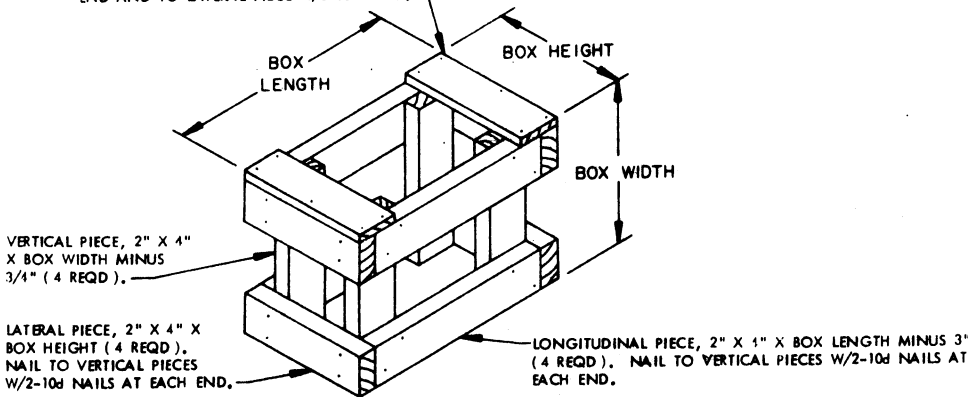

FILLER ASSEMBLY

(FOR MINUS ONE BOX)

GENERAL NOTES

- A. THIS APPENDIX CANNOT STAND ALONE BUT MUST BE USED IN CONJUNCTION WITH THE BASIC UNITIZATION PROCEDURES DRAWING 19-48-4116-20PA1002. TO PRODUCE AN APPROVED UNIT LOAD, ALL PERTINENT PROCEDURES, SPECIFICATIONS AND CRITERIA SET FORTH WITHIN THE BASIC DRAWING WILL APPLY TO THE PROCEDURES DELINEATED IN THIS APPENDIX. ANY EXCEPTIONS TO THE BASIC PROCEDURES ARE SPECIFIED IN THIS APPENDIX.
- B. DIMENSIONS, CUBE AND WEIGHT OF A PALLET UNIT WILL VARY SLIGHTLY DEPENDING UPON THE ACTUAL DIMENSIONS OF THE BOXES AND THE WEIGHT OF THE SPECIFIC ITEM BEING UNITIZED.
- C. THE LOAD STRAPS MAY BE THREADED THROUGH THE STRAP SLOTS OF A PALLET OR PRE-POSITIONED ON THE PALLET DECK PRIOR TO PLACING BOXES ON THE PALLET. LOAD STRAPS MUST BE TENSIONED AND SEALED PRIOR TO APPLICATION OF TIEDOWN STRAPS.
- D. INSTALL EACH TIEDOWN STRAP TO PASS UNDER THE TOP DECK BOARDS OF THE PALLET AND TO BE LOCATED AS SHOWN. TIEDOWN STRAPS WILL NOT BE APPLIED UNTIL THE LOAD STRAPS HAVE BEEN TENSIONED AND SEALED.
- E. THE FOLLOWING DARCOM DRAWINGS ARE APPLICABLE FOR OUT-LOADING AND STORAGE OF THE ITEMS COVERED BY THIS APPENDIX.

CARLOADING -----	DRAWING 19-48-4115-SPA1002
TRUCKLOADING -----	DRAWING 19-48-4117-11PA1003
STORAGE -----	DRAWING 19-48-4118-1-14-22PA1002
- F. FOR METHOD OF SECURING A STRAP CUTTER TO THE PALLET UNIT, SEE DARCOM DRAWING 19-48-4127-20P1000.
- G. IF ITEMS COVERED HEREIN ARE UNITIZED PRIOR TO ISSUANCE OF THIS APPENDIX, THE BOXES NEED NOT BE REUNITIZED SOLELY TO CONFORM TO THIS APPENDIX.
- H. THE UNITIZATION PROCEDURES DEPICTED HEREIN MAY ALSO BE USED FOR UNITIZING C'AFF WHEN IDENTIFIED BY DIFFERENT NATIONAL STOCK NUMBERS (NSN) THAN WHAT IS SHOWN ON THE TITLE PAGE, PROVIDED THE BOX PACK DOES NOT VARY FROM WHAT IS DELINEATED HEREIN. THE EXPLOSIVE CLASSIFICATION OF OTHER ITEMS MAY BE DIFFERENT THAN WHAT IS SHOWN.