

APPENDIX 115B

UNITIZATION PROCEDURES FOR BOXED AMMUNITION AND COMPO- NENTS ON 4-WAY ENTRY PALLETS

FLARE, COUNTERMEASURE OR IR COUNTERMEASURE DECOY, PACKED VARIOUS QUANTITIES PER WIREBOUND BOX, UNITIZED 36 BOXES PER 40" X 48" PALLET; APPROX BOX SIZE 14-5/8" L X 13-1/8" W X 11-3/8" H

NOTICE: THIS APPENDIX CANNOT STAND ALONE BUT MUST BE USED IN CONJUNCTION WITH THE BASIC UNITIZATION PROCEDURES DRAWING 19-48-4116-20PA1002.

DISTRIBUTION STATEMENT A:

APPROVED FOR PUBLIC RELEASE
DISTRIBUTION IS UNLIMITED.

U.S. ARMY MATERIEL COMMAND DRAWING

<p>APPROVED, U.S. ARMY RESEARCH, DEVELOPMENT AND ENGINEERING COMMAND</p> <p>REHMSTEDT.MA RK.J.1230548400</p> <p style="font-size: small;">Digitally signed by REHMSTEDT.MARK.J.1230548400 DN: cn=US, o=U.S. Government, ou=DoD, ou=PKI, ou=USA, c=US cm=REHMSTEDT.MARK.J.1230548400 Date: 2010.12.28 13:45:28 -06'00'</p> <p style="text-align: right;">RDAR-EIL-TP</p>	<p>CAUTION: VERIFY PRIOR TO USE AT WWW.DAC.ARMY.MIL THAT THIS IS THE MOST CURRENT VERSION OF THIS DOCUMENT. THIS IS PAGE 1 OF 4.</p>													
<p>APPROVED, U.S. ARMY JOINT MUNITIONS COMMAND</p> <p>CASILLAS.GILBE RT.J.1230393644</p> <p style="font-size: small;">Digitally signed by CASILLAS.GILBERT.J.1230393644 DN: cn=US, o=U.S. Government, ou=DoD, ou=PKI, ou=USA, c=US cm=CASILLAS.GILBERT.J.1230393644 Date: 2011.01.05 07:00:05 -06'00'</p> <p style="text-align: right;">AMSJM-LIT</p>	<p>DO NOT SCALE</p> <table border="1" style="width: 100%; border-collapse: collapse;"> <tr> <td style="width: 20%;">ENGINEER OR TECHNICIAN</td> <td style="width: 10%;">BASIC</td> <td style="width: 70%;">WILLIAM R. FRERICHS</td> </tr> <tr> <td></td> <td>REV.</td> <td>MADELINE BANKS</td> </tr> </table>	ENGINEER OR TECHNICIAN	BASIC	WILLIAM R. FRERICHS		REV.	MADELINE BANKS	<p>AUGUST 1979</p> <table border="1" style="width: 100%; border-collapse: collapse;"> <tr> <td style="width: 50%;">REVISION NO. 5</td> <td style="width: 50%;">DECEMBER 2010</td> </tr> </table>		REVISION NO. 5	DECEMBER 2010			
ENGINEER OR TECHNICIAN	BASIC	WILLIAM R. FRERICHS												
	REV.	MADELINE BANKS												
REVISION NO. 5	DECEMBER 2010													
<p>APPROVED BY ORDER OF COMMANDING GENERAL, U.S. ARMY MATERIEL COMMAND</p> <p>CARNEY.GARY .BURTON.1038 708038</p> <p style="font-size: small;">Digitally signed by CARNEY.GARY.BURTON.1038708038 DN: cn=US, o=U.S. Government, ou=DoD, ou=PKI, ou=USA, c=US cm=CARNEY.GARY.BURTON.1038708038 Date: 2011.01.05 10:54:50 -06'00'</p> <p style="text-align: center;">U.S. ARMY DEFENSE AMMUNITION CENTER</p>	<p>TRANSPORTATION ENGINEERING DIVISION</p> <p>VALIDATION ENGINEERING DIVISION</p> <p>ENGINEERING DIRECTORATE</p>	<p>FIEFFER.LAUR A.A.1230375727</p> <p>BARICKMAN. PHILIP.W.123 0202202</p> <p>BEAVER.JERRY .W.1230949952</p>	<p style="font-size: x-small;">Digitally signed by FIEFFER.LAURA.A.1230375727 DN: cn=US, o=U.S. Government, ou=DoD, ou=PKI, ou=USA, c=US cm=FIEFFER.LAURA.A.1230375727 Date: 2010.12.03 12:15:38 -06'00'</p> <p style="font-size: x-small;">Digitally signed by BARICKMAN.PHILIP.W.1230202202 DN: cn=US, o=U.S. Government, ou=DoD, ou=PKI, ou=USA, c=US cm=BARICKMAN.PHILIP.W.1230202202 Date: 2010.12.10 11:23:08 -06'00'</p> <p style="font-size: x-small;">Digitally signed by BEAVER.JERRY.W.1230949952 DN: cn=US, o=U.S. Government, ou=DoD, ou=PKI, ou=USA, c=US cm=BEAVER.JERRY.W.1230949952 Date: 2010.12.10 11:23:08 -06'00'</p> <p style="text-align: center;">TESTED</p>	<table border="1" style="width: 100%; border-collapse: collapse;"> <tr> <td style="width: 25%;">SEE THE REVISION LISTING ON PAGE 2</td> <td style="width: 25%;">CLASS</td> <td style="width: 25%;">DIVISION</td> <td style="width: 25%;">DRAWING</td> <td style="width: 25%;">FILE</td> </tr> <tr> <td></td> <td style="text-align: center;">19</td> <td style="text-align: center;">48</td> <td style="text-align: center;">4116/ 115B</td> <td style="text-align: center;">20PA1002</td> </tr> </table>	SEE THE REVISION LISTING ON PAGE 2	CLASS	DIVISION	DRAWING	FILE		19	48	4116/ 115B	20PA1002
SEE THE REVISION LISTING ON PAGE 2	CLASS	DIVISION	DRAWING	FILE										
	19	48	4116/ 115B	20PA1002										

PALLET UNIT DATA				
ITEMS INCLUDED		*HAZARD CLASS AND DIVISION	*COMPATIBILITY GROUP	APPROX WEIGHT (LBS)
NSN	DODIC			
1370-				
01-048-2138	L410	1. 3	G	2, 502
01-460-1684	LA14	4. 2	G	2, 918
01-534-9804	LA14	4. 2	G	2, 918
01-460-1687	LA15	1. 3	G	2, 864
01-534-3060	LA15	1. 3	G	2, 864
01-468-6077	LA19	4. 2	G	2, 682
01-468-6076	LA20	4. 2	G	2, 610
01-495-9793	LA30	1. 3	G	2, 214
01-495-9790	LA31	1. 3	G	3, 657

*HAZARD AND CLASSIFICATION DATA CONTAINED IN THE ABOVE CHART IS FOR GUIDANCE AND INFORMATIONAL PURPOSES ONLY. VERIFICATION OF THE SPECIFIED DATA SHOULD BE MADE BY CONSULTING THE MOST RECENT JOINT HAZARD CLASSIFICATION SYSTEM LISTING OR OTHER APPROVED LISTING(S).

REVISIONS

REVISION NO. 1, DATED MAY 1996, CONSISTS OF:

1. CHANGING BOX SIZE AND WEIGHT.
2. CHANGING PALLET CONFIGURATION FROM A 35" X 45-1/2" PALLET TO A 40' X 48" PALLET.
3. DELETING GENERAL NOTE RELATING TO STRAP CUTTER AND RE-LETTERING OTHER GENERAL NOTES.

REVISION NO. 2, DATED JANUARY 2001, CONSISTS OF:

1. CHANGING TITLE.
2. UPDATING DRAWING FORMAT.
3. ADDING ITMES BY NATIONAL STOCK NUMBER (NSN) TO THE "PALLET UNIT DATA CHART".
4. ADDING BOX DRAWING REFERNCE GENERAL NOTE.

REVISION NO. 3, DATED FEBRUARY 2003, CONSISTS OF:

1. ADDING ITEMS BY NATIONAL STOCK NUMBER (NSN) TO THE "PALLET UNIT DATA CHART".
2. ADDING TWO ADDITIONAL TIEDOWN STRAPS TO ACCOMMODATE THE 99 POUND BOX (LA31).
3. ADDING SECOND TIEDOWN STRAP GENERAL NOTE IAW 2 ABOVE.

REVISION NO. 4, DATED APRIL 2009, CONSISTS OF:

1. ADDING ITEMS BY NATIONAL STOCK NUMBER (NSN) TO THE "PALLET UNIT DATA CHART" IN ACCORDANCE WITH ECP R08K3009.
2. UPDATING DRAWING FORMAT.

REVISION NO. 5, DATED DECEMBER 2010, CONSISTS OF CHANGES PER ECP R10K3002:

1. ADDING ITEMS BY NATIONAL STOCK NUMBER (NSN) TO THE "PALLET UNIT DATA CHART".
2. UPDATING GENERAL NOTES "J" (BOX ORIENTATION) AND "N" (BOX DRAWING NUMBERS).
3. ADDING HORIZONTAL STRAPS AND MAKING LOAD STRAPS ALTERNATIVE.
4. ADDING GENERAL NOTES "L" (ALTERNATIVE STRAPS) AND "M" (BOX HANDLES).
5. CHANGING BOX DIMENSIONS.

GENERAL NOTES

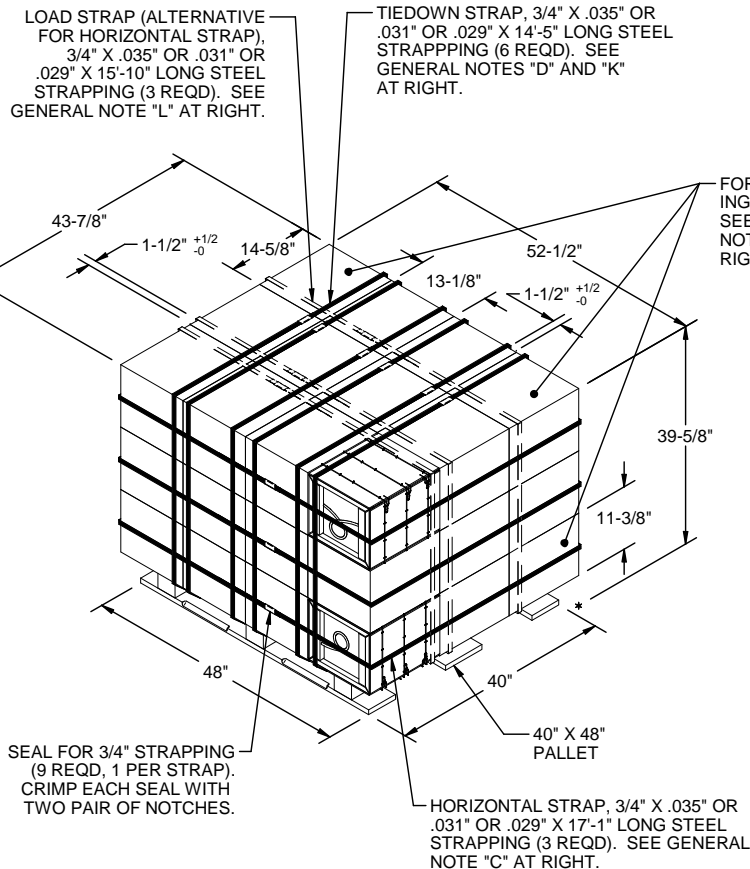

FOR POSITIONING OF BOXES SEE GENERAL NOTE "J" AT RIGHT.

PALLET UNIT
SEE GENERAL NOTE "B" AT RIGHT.

36 BOXES OF FLARES (100 PER BOX) @ 99 LBS	-----	3,564 LBS (APPROX)
DUNNAGE	-----	13 LBS*
PALLET	-----	80 LBS
<hr/>		
TOTAL WEIGHT	-----	3,657 LBS (APPROX)
CUBE	-----	52.8 CU FT (APPROX)

*SEE GENERAL NOTE "K" AT RIGHT

BILL OF MATERIAL

PALLET, 40" X 48"	-----	1 REQD	-----	80 LBS
STEEL STRAPPING, 3/4"	-----	137.75' REQD	-----	12.30 LBS
SEAL FOR 3/4" STRAPPING	-----	9 REQD	-----	NIL

- A. THIS APPENDIX CANNOT STAND ALONE BUT MUST BE USED IN CONJUNCTION WITH THE BASIC UNITIZATION PROCEDURES DRAWING 19-48-4116-20PA1002. TO PRODUCE AN APPROVED UNIT LOAD, ALL PERTINENT PROCEDURES, SPECIFICATIONS AND CRITERIA SET FORTH WITHIN THE BASIC DRAWING WILL APPLY TO THE PROCEDURES DELINEATED IN THIS APPENDIX. ANY EXCEPTIONS TO THE BASIC PROCEDURES ARE SPECIFIED IN THIS APPENDIX.
- B. DIMENSIONS, CUBE AND WEIGHT OF A PALLET UNIT WILL VARY SLIGHTLY DEPENDING UPON THE ACTUAL DIMENSIONS OF THE BOXES AND THE WEIGHT OF THE SPECIFIC ITEM BEING UNITIZED.
- C. INSTALL EACH HORIZONTAL STRAP TO BE LOCATED AS SHOWN. HORIZONTAL STRAPS MUST BE TENSIONED AND SEALED AFTER THE APPLICATION OF TIEDOWN STRAPS.
- D. INSTALL EACH TIEDOWN STRAP TO PASS UNDER THE TOP DECK BOARDS OF THE PALLET AND TO BE LOCATED AS SHOWN. TIEDOWN STRAPS WILL NOT BE APPLIED UNTIL THE HORIZONTAL STRAPS HAVE BEEN TENSIONED AND SEALED.
- E. THE FOLLOWING AMC DRAWINGS ARE APPLICABLE FOR OUTLOADING AND STORAGE OF THE ITEMS COVERED BY THIS APPENDIX.

CARLOADING	-----	19-48-4115-5PA1002
TRUCKLOADING	-----	19-48-4117-11PA1003
STORAGE	-----	19-48-4118-1-2-3-4-14-22PA1002
END OPENING ISO CONTAINER	-----	19-48-4153-15PA1002
MILVAN	-----	19-48-4166-15PA1003
SIDE OPENING ISO CONTAINER	-----	19-48-4267-15PA1009
- F. IF ITEMS COVERED HEREIN ARE UNITIZED PRIOR TO ISSUANCE OF THIS REVISION TO THIS APPENDIX, THE BOXES NEED NOT BE REUNITIZED SOLELY TO CONFORM TO THIS REVISION.
- G. THE UNITIZATION PROCEDURES DEPICTED HEREIN MAY ALSO BE USED FOR UNITIZING FLARES OR DECOYS WHEN IDENTIFIED BY DIFFERENT NATIONAL STOCK NUMBERS (NSN) THAN WHAT IS SHOWN ON PAGE 2, PROVIDED THE BOX PACK DOES NOT VARY FROM WHAT IS DELINEATED HEREIN. THE EXPLOSIVE CLASSIFICATION OF OTHER ITEMS MAY BE DIFFERENT THAN WHAT IS SHOWN.
- H. THE STYLE 1 PALLET DELINEATED IN THE DETAIL AT LEFT NEED NOT HAVE CHAMFERS OR STRAP SLOTS AS SPECIFIED WITHIN MILITARY SPECIFICATION MIL-P-15011 WHEN USED FOR THE UNITIZATION OF ITEMS COVERED BY THIS APPENDIX.
- J. POSITION THE SIX OUTBOARD BOXES ON THE 40" SIDES OF THE BOTTOM LAYER OF THE UNIT WITH THE TOPS DOWNWARD, AND THE SIX OUTBOARD BOXES ON THE 40" SIDES OF THE TOP LAYER OF THE UNIT WITH THE TOPS TURNED UPWARDS.
- K. WHEN THE TOTAL WEIGHT OF A 36-BOX UNIT IS 2,800 POUNDS OR LESS, ONLY FOUR TIEDOWN STRAPS WILL BE REQUIRED TO RETAIN THE BOXES ON THE PALLET. ELIMINATE THE TWO CENTER TIEDOWN STRAPS. THIS WILL RESULT IN A REDUCED DUNNAGE WEIGHT OF 9.73 POUNDS AND A TOTAL STRAPPING REQUIREMENT OF 108.92 FEET.
- L. LOAD STRAPS MAY BE USED AS AN ALTERNATIVE TO HORIZONTAL STRAPS. THE LOAD STRAPS MUST BE PRE-POSITIONED ON THE PALLET DECK PRIOR TO PLACING BOXES ON THE PALLET. NOTE THAT THE LOAD STRAPS WILL BE LOCATED AS SHOWN. LOAD STRAPS MUST BE TENSIONED AND SEALED PRIOR TO APPLICATION OF TIEDOWN STRAPS
- M. THE DETAIL ABOVE DEPICTS HANDLES ON THE DETAILED BOXES. THE ACTUAL BOXES TO BE UNITIZED MAY OR MAY NOT HAVE HANDLES, DEPENDING ON THE MODEL OF THE ITEM TO BE UNITIZED. IF THE BOXES DO CONTAIN HANDLES, THEN THE HANDLES MAY BE EITHER WEBBING OR ROPE STYLE.
- N. FOR DETAILS OF THE WIREBOUND BOX SEE DRAWING 9313716, 12988808, OR 12988845.

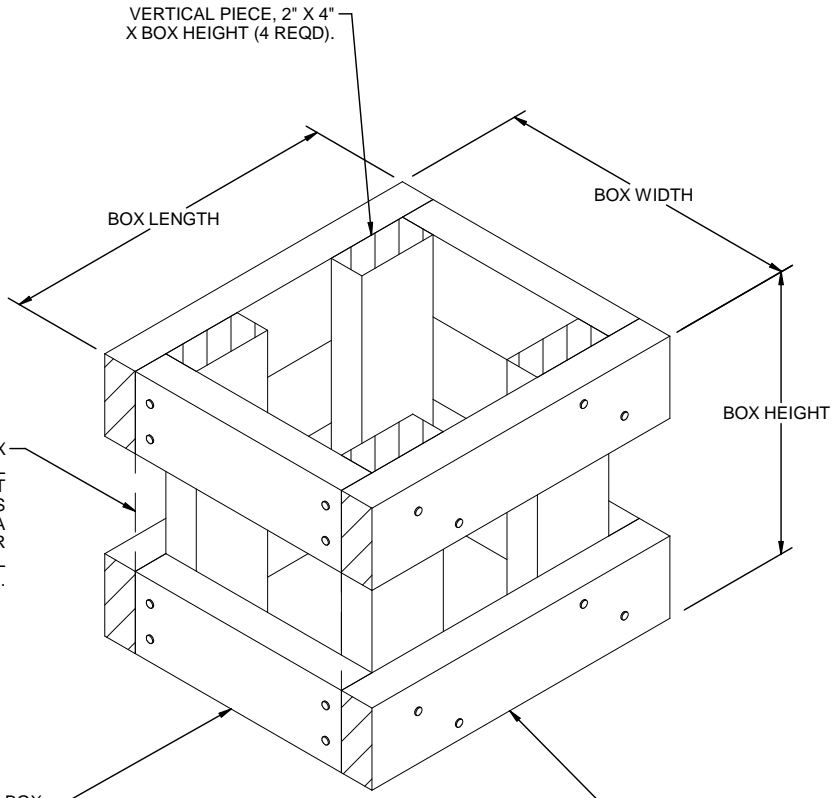

FILLER PIECE, 2" X 6" (RIPPED TO FIT) X BOX WIDTH MINUS 3" (AS REQD). NAIL TO VERTICAL PIECES W/2-10d NAILS AT EACH END. NOTE THAT WHEN A UNIT HAS MORE THAN FOUR BOXES OMITTED, A FILLER ASSEMBLY LOCATED IN AN OUTER STACK ON A 48" SIDE OF THE PALLET WILL REQUIRE A FILLER PIECE AS SHOWN.

LATERAL PIECE, 2" X 4" X BOX WIDTH MINUS 3" (4 REQD). NAIL TO VERTICAL PIECES W/2-10d NAILS AT EACH END.

LONGITUDINAL PIECE, 2" X 4" X BOX LENGTH (4 REQD). NAIL TO VERTICAL PIECES W/2-10d NAILS AT EACH JOINT.

FILLER ASSEMBLY
(FOR MINUS ONE BOX)