

APPENDIX 115A

UNITIZATION PROCEDURES FOR BOXED AMMUNITION AND COMPONENTS ON 4-WAY ENTRY PALLETS

CARTRIDGE, 25.4MM, DECOY, M839, PACKED 50 PER
PA19 SERIES METAL CONTAINER, 2 PER WOODEN
BOX, UNITIZED 24 BOXES PER 40" X 48" PALLET;
APPROX BOX SIZE 14 $\frac{1}{2}$ " L X 13 $\frac{3}{8}$ " W X 13 $\frac{1}{4}$ " H

| PALLET UNIT DATA | | | | | | |
|----------------------|-------|-----------------------|-------------|-------------|---------------|-----------------|
| ITEMS INCLUDED | | HAZARD CLASSIFICATION | | | | WEIGHT (LBS) |
| NSN | DODIC | DOT CLASS | CG CLASS | QD CLASS | COMP GROUP | |
| 1305- 01-082-8986 | A965 | C | I | 1.4 | S | 1,695 |

NOTICE: THIS APPENDIX CANNOT STAND ALONE BUT MUST
BE USED IN CONJUNCTION WITH THE BASIC UNITIZATION
PROCEDURES DRAWING 19-48-4116-20PA1002.

REVISION

REVISION NO. 1, DATED AUGUST 1981, CONSISTS OF:

1. ADDING NATIONAL STOCK NUMBER TO "PALLET UNIT DATA" CHART.
2. UPDATING STORAGE DRAWING NUMBER.

DO NOT SCALE

| REVISIONS | | | | DRAFTSMAN <i>GRG/mak</i> | PROJ ENG <i>WRF/KW</i> |
|--|----------|---------------|---------------|---|---------------------------|
| 1 | AUG 81 | <i>WRF</i> | <i>WRF/KW</i> | <i>RSW</i> | <i>W7 Ernst</i> |
| APPROVED, U. S. ARMY ARMAMENT MATERIEL READINESS COMMAND | | | | <small>APPROVED BY ORDER OF COMMANDING GENERAL, U. S. ARMY MATERIEL DEVELOPMENT AND READINESS COMMAND (DARCOM)</small> <i>John L. Boyd Jr.</i> <small>U. S. ARMY DEFENSE AMMUNITION CENTER AND SCHOOL</small> | |
| U. S. ARMY DARCOM DRAWING | | | | | |
| OCTOBER 1979 | | | | | |
| CLASS | DIVISION | DRAWING | FILE | | |
| 19 | 48 | 4116/ 115A | 20PA 1002 | | |

TIEDOWN STRAP, 3/4" X .035" OR .031" X 12'-9" LONG STEEL STRAPPING (4 REQD). SEE GENERAL NOTE "C" AT RIGHT.

SEAL FOR 3/4" STRAPPING (6 REQD, 1 PER STRAP). CRIMP EACH SEAL WITH TWO PAIR OF NOTCHES.

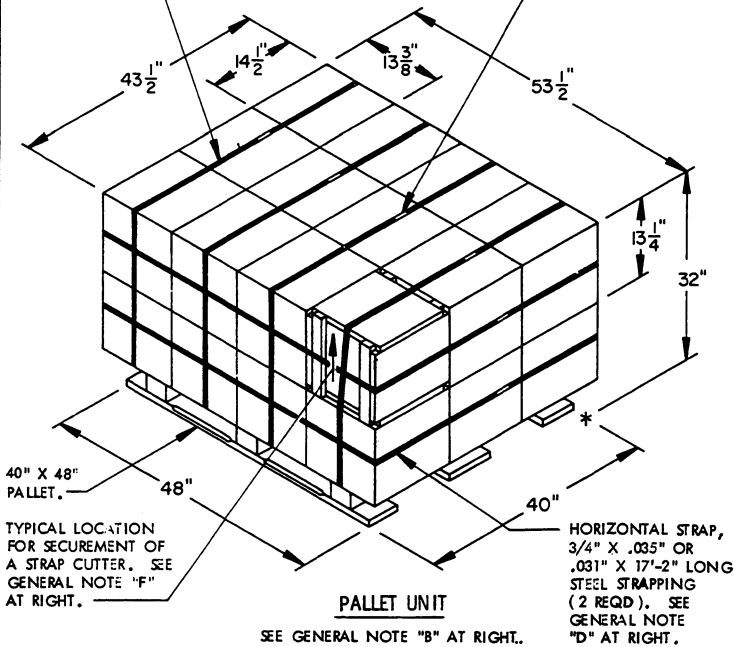

24 BOXES OF 25.4MM CARTRIDGE (100 PER BOX) @ 67 LBS ----- 1,608 LBS (APPROX)
 DUNNAGE ----- 7 LBS
 PALLET ----- 80 LBS

TOTAL WEIGHT ----- 1,695 LBS (APPROX)
 CUBE ----- 43.1 CU FT (APPROX)

GENERAL NOTES

- A. THIS APPENDIX CANNOT STAND ALONE BUT MUST BE USED IN CONJUNCTION WITH THE BASIC UNITIZATION PROCEDURES DRAWING 19-48-4116-20PA1002. TO PRODUCE AN APPROVED UNIT LOAD, ALL PERTINENT PROCEDURES, SPECIFICATIONS AND CRITERIA SET FORTH WITHIN THE BASIC DRAWING WILL APPLY TO THE PROCEDURES DELINEATED IN THIS APPENDIX. ANY EXCEPTIONS TO THE BASIC PROCEDURES ARE SPECIFIED IN THIS APPENDIX.
- B. DIMENSIONS, CUBE AND WEIGHT OF A PALLET UNIT WILL VARY SLIGHTLY DEPENDING UPON THE ACTUAL DIMENSIONS OF THE BOXES AND THE WEIGHT OF THE SPECIFIC ITEM BEING UNITIZED.
- C. INSTALL EACH TIEDOWN STRAP TO PASS UNDER THE TOP DECK BOARDS OF THE PALLET AND BE LOCATED AS SHOWN. TIEDOWN STRAPS WILL BE APPLIED BUT NOT TENSIONED UNTIL THE HORIZONTAL STRAPS HAVE BEEN TENSIONED AND SEALED.
- D. INSTALL EACH HORIZONTAL STRAP TO ENCIRCLE EACH LAYER OF BOXES ON THE PALLET. HORIZONTAL STRAPS MUST BE TENSIONED AND SEALED PRIOR TO TENSIONING OF TIEDOWN STRAPS.
- E. THE FOLLOWING DARCOM DRAWINGS ARE APPLICABLE FOR OUTLOADING AND STORAGE OF THE ITEMS COVERED BY THIS APPENDIX.

| | |
|--------------------|--|
| CARLOADING ----- | DRAWING 19-48-4115-5PA1002 |
| TRUCKLOADING ----- | DRAWING 19-48-4117-11PA1003 |
| STORAGE ----- | DRAWING 19-48-4118-1-2-3-4-14-22PA1002 |
- F. FOR METHOD OF SECURING A STRAP CUTTER TO THE PALLET UNIT, SEE DARCOM DRAWING 19-48-4127-20P1000.
- G. IF ITEMS COVERED HEREIN ARE UNITIZED PRIOR TO ISSUANCE OF THIS APPENDIX, THE BOXES NEED NOT BE REUNITIZED SOLELY TO CONFORM TO THIS APPENDIX.
- H. THE UNITIZATION PROCEDURES DEPICTED HEREIN MAY ALSO BE USED FOR UNITIZING 25.4MM CARTRIDGES WHEN IDENTIFIED BY DIFFERENT NATIONAL STOCK NUMBERS (NSN) THAN WHAT IS SHOWN ON THE TITLE PAGE, PROVIDED THE BOX PACK DOES NOT VARY FROM WHAT IS DELINEATED HEREIN. THE EXPLOSIVE CLASSIFICATION OF OTHER ITEMS MAY BE DIFFERENT THAN WHAT IS SHOWN.

BILL OF MATERIAL

| | | |
|-------------------------|------------|----------|
| PALLET, 40" X 48" | 1 REQD | 80 LBS |
| STEEL STRAPPING, 3/4" | 85.33 REQD | 6.10 LBS |
| SEAL FOR 3/4" STRAPPING | 6 REQD | NIL |

TIE PIECE, 1" X 4" X BOX WIDTH (2 REQD). NAIL TO LONGITUDINAL PIECES W/1-6d NAIL AT EACH END AND TO LATERAL PIECE W/3-6d NAILS.

END CLEATS, 1" X 4" X BOX HEIGHT MINUS 3/4" (4 REQD). NAIL TO LATERAL PIECES W/2-6d NAILS AT EACH END.

LATERAL PIECE, 2" X 4" X BOX WIDTH (4 REQD). NAIL TO VERTICAL PIECES W/2-10d NAILS AT EACH END.

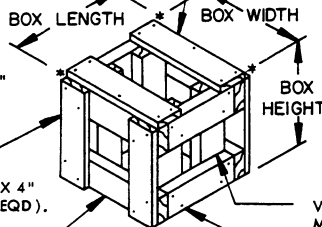

VERTICAL PIECE, 2" X 4" X BOX HEIGHT MINUS 3/4" (4 REQD).

LONGITUDINAL PIECE, 2" X 4" X BOX LENGTH MINUS 4-1/2" (4 REQD). NAIL TO VERTICAL PIECES W/2-10d NAILS AT EACH END.

FILLER ASSEMBLY
(FOR MINUS ONE BOX)