

APPENDIX 113B

UNITIZATION PROCEDURES FOR BOXED AMMUNITION AND COMPO- NENTS ON 4-WAY ENTRY PALLETS

**SIMULATOR, BOOBY TRAP, WHISTLING, PACKED
150 PER WIREBOUND BOX, UNITIZED 30 BOXES PER
40" X 48" PALLET; APPROX BOX SIZE 18-1/2" L X 13-
1/2" W X 10" H**

NOTICE: THIS APPENDIX CANNOT STAND ALONE BUT MUST BE USED IN CONJUNCTION WITH THE BASIC UNITIZATION
PROCEDURES DRAWING 19-48-4116-20PA1002.

DISTRIBUTION STATEMENT A:

APPROVED FOR PUBLIC RELEASE
DISTRIBUTION IS UNLIMITED.

U.S. ARMY MATERIEL COMMAND DRAWING

<p>APPROVED, U.S. ARMY FIELD SUPPORT COMMAND <i>T.P.R.</i> <i>David G. Pedroni</i> AMSRD-AAR-AIL-TP</p>	<p>CAUTION: VERIFY PRIOR TO USE AT WWW.DAC.ARMY.MIL THAT THIS IS THE MOST CURRENT VERSION OF THIS DOCUMENT. THIS IS PAGE 1 OF 4.</p>		
<p><i>David G. Pedroni</i> AMSFSS-ST</p>	DO NOT SCALE		JULY 1980
	ENGINEER OR TECHNICIAN	BASIC REV.	GEORGE FECKE PATRICK DOUGHERTY
<p>APPROVED BY ORDER OF COMMANDING GENERAL, U.S. ARMY MATERIEL COMMAND <i>J. P. Williams</i></p>	TRANSPORTATION ENGINEERING DIVISION	SEE THE REVISION LISTING ON PAGE 2	
<p>U.S. ARMY DEFENSE AMMUNITION CENTER</p>	VALIDATION ENGINEERING DIVISION	TESTED	CLASS
	ENGINEERING DIRECTORATE	DIVISION	DRAWING
		FILE	FILE
	19	48	4116/ 113B
			20PA1002

PALLET UNIT DATA				
ITEMS INCLUDED		*HAZARD CLASS AND DIVISION	*COMPATIBILITY GROUP	APPROX WEIGHT (LBS)
NSN	DODIC			
1370-00-028-5255	L600	1. 3	G	1, 559

*HAZARD AND CLASSIFICATION DATA CONTAINED IN THE ABOVE CHART IS FOR GUIDANCE AND INFORMATIONAL PURPOSES ONLY. VERIFICATION OF THE SPECIFIED DATA SHOULD BE MADE BY CONSULTING THE MOST RECENT JOINT HAZARD CLASSIFICATION SYSTEM LISTING OR OTHER APPROVED LISTING(S).

REVISIONS

REVISION NO. 1, DATED MAY 1985, CONSISTS OF:

1. CHANGING BOX DIMENSIONS.
2. UPDATING PALLET UNIT TO CONFORM WITH 1 ABOVE.

REVISION NO. 2, DATED OCTOBER 1989, CONSISTS OF:

1. CHANGING BOX TYPE.
2. CHANGING BOX WEIGHT.
3. UPDATING PALLET UNIT TO CONFORM WITH 1 AND 2 ABOVE.

REVISION NO. 3, DATED JULY 2005, CONSISTS OF:

1. DELETING NOTE FOR STRAP CUTTER.
2. UPDATING DRAWING FORMAT AND GENERAL NOTES.

GENERAL NOTES

SEAL FOR 3/4" STRAPPING
(7 REQ'D, 1 PER STRAP).
CRIMP EACH SEAL WITH
TWO PAIR OF NOTCHES.

TIEDOWN STRAP, 3/4" X .035" OR
.031" X 14'-0" LONG STEEL
STRAPPING (5 REQ'D). SEE
GENERAL NOTE "D" AT RIGHT.

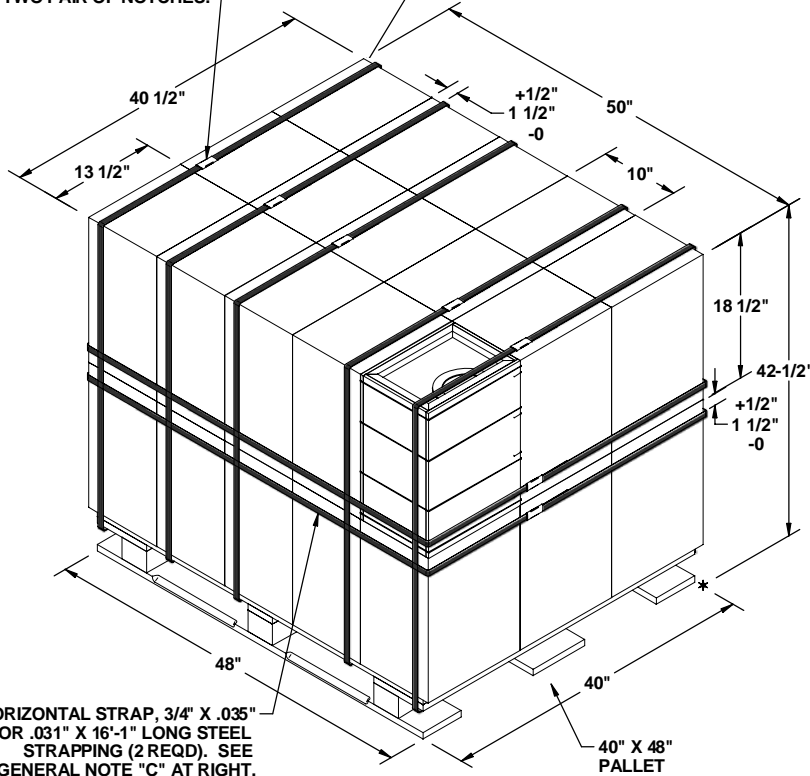

HORIZONTAL STRAP, 3/4" X .035"
OR .031" X 16'-1" LONG STEEL
STRAPPING (2 REQ'D). SEE
GENERAL NOTE "C" AT RIGHT.

PALLET UNIT
SEE GENERAL NOTE "B" AT RIGHT.

30 BOXES OF SIMULATORS (150 PER BOX) @ 49 LBS	1,470 LBS
DUNNAGE	9 LBS
PALLET	80 LBS

TOTAL WEIGHT	1,559 LBS (APPROX)
CUBE	49.8 CU FT (APPROX)

A. THIS APPENDIX CANNOT STAND ALONE BUT MUST BE USED IN CONJUNCTION WITH THE BASIC UNITIZATION PROCEDURES DRAWING 19-48-4116-20PA1002. TO PRODUCE AN APPROVED UNIT LOAD, ALL PERTINENT PROCEDURES, SPECIFICATIONS AND CRITERIA SET FORTH WITHIN THE BASIC DRAWING WILL APPLY TO THE PROCEDURES DELINEATED IN THIS APPENDIX. ANY EXCEPTIONS TO THE BASIC PROCEDURES ARE SPECIFIED IN THIS APPENDIX.

B. DIMENSIONS, CUBE AND WEIGHT OF A PALLET UNIT WILL VARY SLIGHTLY DEPENDING UPON THE ACTUAL DIMENSIONS OF THE BOXES AND THE WEIGHT OF THE SPECIFIC ITEM BEING UNITIZED.

C. INSTALL EACH HORIZONTAL STRAP TO ENCIRCLE A LAYER OF BOXES ON THE PALLET. HORIZONTAL STRAPS MUST BE TENSIONED AND SEALED PRIOR TO APPLICATION OF THE TIEDOWN STRAPS.

D. INSTALL EACH TIEDOWN STRAP TO PASS UNDER THE DECK/STRINGER BOARDS OF THE PALLET AND TO BE LOCATED AS SHOWN. TIEDOWN STRAPS WILL NOT BE APPLIED UNTIL THE HORIZONTAL STRAPS HAVE BEEN TENSIONED AND SEALED.

E. THE FOLLOWING AMC DRAWINGS ARE APPLICABLE FOR OUTLOADING AND STORAGE OF THE ITEMS COVERED BY THIS APPENDIX.

CARLOADING	19-48-4115-5PA1002
TRUCKLOADING	19-48-4117-11PA1003
STORAGE	19-48-4118-1-2-3-4-14-22PA1002

END OPENING ISO CONTAINER	19-48-4153-15PA1002
MILVAN	19-48-4166-15PA1003
SIDE OPENING ISO CONTAINER	19-48-4267-15PA1009

F. IF ITEMS COVERED HEREIN ARE UNITIZED PRIOR TO ISSUANCE OF THIS REVISION TO THIS APPENDIX, THE BOXES NEED NOT BE REUNITIZED SOLELY TO CONFORM TO THIS APPENDIX.

G. THE UNITIZATION PROCEDURES DEPICTED HEREIN MAY ALSO BE USED FOR UNITIZING SIMULATOR, BOOBY TRAP WHEN IDENTIFIED BY DIFFERENT NATIONAL STOCK NUMBERS (NSN) THAN WHAT IS SHOWN ON PAGE 2, PROVIDED THE BOX PACK DOES NOT VARY FROM WHAT IS DELINEATED HEREIN. THE EXPLOSIVE CLASSIFICATION OF OTHER ITEMS MAY BE DIFFERENT THAN WHAT IS SHOWN.

H. THE STYLE 1 PALLET DELINEATED IN THE DETAIL AT LEFT NEED NOT HAVE CHAMFERS OR STRAP SLOTS AS SPECIFIED WITHIN MILITARY SPECIFICATION MIL-P-15011 WHEN USED FOR THE UNITIZATION OF ITEMS COVERED BY THIS APPENDIX.

J. FOR DETAILS OF THE MIL-B-46506 WIREBOUND BOX SEE ARDEC DRAWING 9354477.

BILL OF MATERIAL

PALLET, 40" X 48"	1 REQ'D	80 LBS
STEEL STRAPPING, 3/4"	102.17' REQ'D	9.12 LBS
SEAL FOR 3/4" STRAPPING	7 REQ'D	NIL

TIE PIECE, 1" X 4" BY BOX HEIGHT
(2 REQD). NAIL TO LONGITUDINAL
PIECE W/3-6d NAILS AND TO LATERAL
PIECE W/1-6d NAIL AT EACH END.

VERTICAL PIECE, 2" X 4" BY BOX
LENGTH MINUS 3/4" (4 REQD).

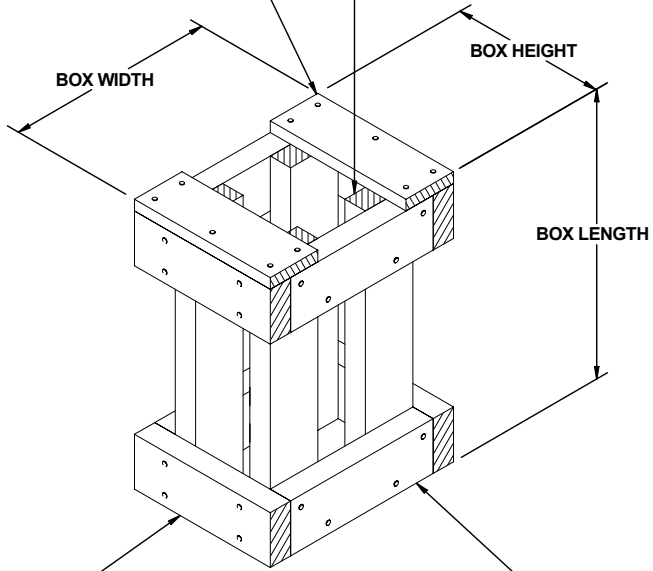

LONGITUDINAL PIECE, 2" X 4"
BY BOX HEIGHT (4 REQD).
NAIL TO VERTICAL PIECES
W/2-10d NAILS AT EACH JOINT.

LATERAL PIECE, 2" X 4" BY BOX WIDTH
MINUS 3" (4 REQD). NAIL TO VERTICAL
PIECES W/2-10d NAILS AT EACH JOINT.

FILLER ASSEMBLY
FOR MINUS ONE BOX