

# APPENDIX 112A

## UNITIZATION PROCEDURES FOR BOXED AMMUNITION AND COMPONENTS ON 4-WAY ENTRY PALLETS

M21 ARTILLERY FLASH SIMULATOR, PACKED 162  
PER WOODEN BOX, UNITIZED 12 BOXES PER 42"  
X 53" PALLET; APPROX BOX SIZE 22" L X  
15-7/8" W X 21-1/16" H

NOTICE: THIS APPENDIX CANNOT STAND ALONE BUT MUST BE USED IN CONJUNCTION WITH  
THE BASIC UNITIZATION PROCEDURES DRAWING 19-48-4116-20PA1002.

**DISTRIBUTION STATEMENT A.**

APPROVED FOR PUBLIC RELEASE;  
DISTRIBUTION IS UNLIMITED.

U. S. ARMY MATERIEL COMMAND DRAWING				
APPROVED, U. S. ARMY ARMAMENT, MUNITIONS AND CHEMICAL COMMAND <i>N.H.</i> <i>David D. Perkowski</i> AMSTA-AR-ESK	DRAFTSMAN ENGINEER D. WHITMORE SANDRA M. SCHULTZ			
<i>David D. Perkowski</i> AMSTA-AR-ESK	<i>T. J. McMillan</i> SUPPLY ENGINEERING DIVISION	<i>Diana C. Fisher</i> TRANSPORTATION ENGINEERING DIVISION	<i>W. H. ...</i> VALIDATION ENGINEERING DIVISION	
APPROVED BY ORDER OF COMMANDING GENERAL, U. S. ARMY MATERIEL COMMAND <i>William F Ernst</i> U. S. ARMY DEFENSE AMMUNITION CENTER AND SCHOOL	LOGISTICS ENGINEERING OFFICE <i>William F Ernst</i> NOVEMBER 1980			
	CLASS	DIVISION	DRAWING	FILE
REVISION NO. 4	JANUARY 1995	19	48	4116/ 112A
SEE THE REVISION LISTING ON PAGE 2				20PA 1002

DO NOT SCALE

PALLET UNIT DATA				
ITEMS INCLUDED		HAZARD CLASS AND DIVISION ●		APPROX WEIGHT LBS
NSN	DODIC	OD CLASS	COMP GROUP	
1370-				
01-034-1397	L602	1.4	G	1,212
01-128-0418	L602	1.4	G	1,212
01-344-5849	L709	1.3	G	1,212

- HAZARD CLASSIFICATION DATA CONTAINED IN THE ABOVE CHART IS FOR GUIDANCE AND INFORMATIONAL PURPOSES ONLY. VERIFICATION OF THE SPECIFIED DATA SHOULD BE MADE BY CONSULTING THE MOST RECENT JOINT HAZARD CLASSIFICATION SYSTEM LISTING OR OTHER APPROVED LISTING(S).

### REVISIONS

REVISION NO. 1, DATED JANUARY 1984, CONSISTS OF:

1. ADDING ITEM BY NATIONAL STOCK NUMBER TO "PALLET UNIT DATA" CHART.
2. ADDING HAZARD CLASSIFICATION INFORMATION NOTE.

REVISION NO. 2, DATED APRIL 1986, CONSISTS OF:

1. UPDATING BOX DIMENSION.
2. CHANGING PALLET UNIT TO CONFORM TO 1. ABOVE.

REVISION NO. 3, DATED JULY 1992, CONSISTS OF:

1. ADDING ITEM BY NATIONAL STOCK NUMBER TO "PALLET UNIT DATA" CHART.

REVISION NO. 4, DATED JANUARY 1995, CONSISTS OF:

1. CHANGING THE HAZARD CLASS INFORMATION AND WEIGHT FOR TWO NSN'S ON "PALLET UNIT DATA" CHART.

**GENERAL NOTES**

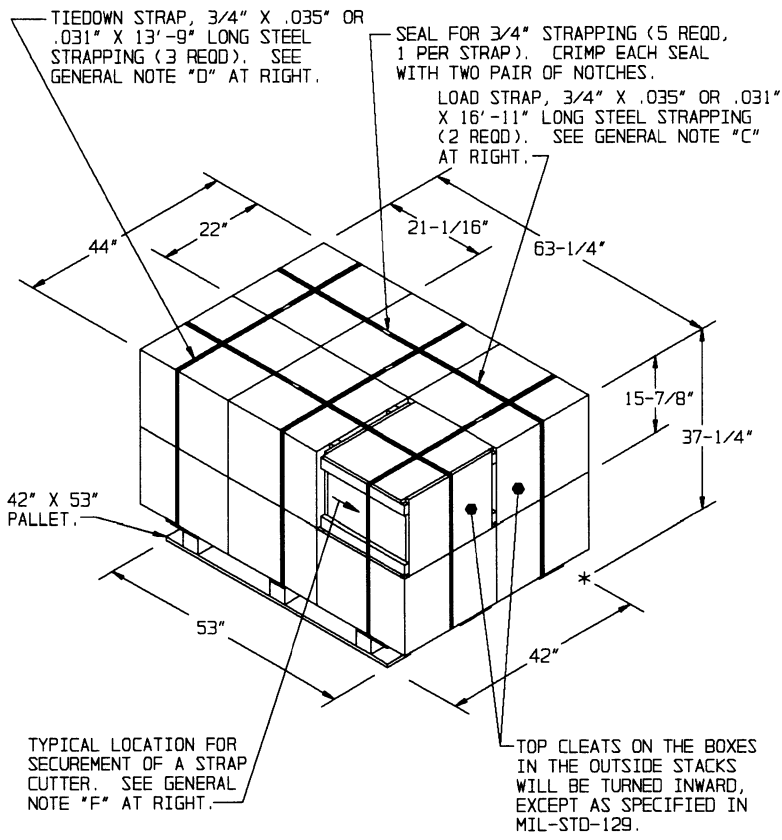

- A. THIS APPENDIX CANNOT STAND ALONE BUT MUST BE USED IN CONJUNCTION WITH THE BASIC UNITIZATION PROCEDURES DRAWING 19 48 4116 20PA1002. TO PRODUCE AN APPROVED UNIT LOAD, ALL PERTINENT PROCEDURES, SPECIFICATIONS AND CRITERIA SET FORTH WITHIN THE BASIC DRAWING WILL APPLY TO THE PROCEDURES DELINEATED IN THIS APPENDIX. ANY EXCEPTIONS TO THE BASIC PROCEDURES ARE SPECIFIED IN THIS APPENDIX.
- B. DIMENSIONS, CUBE AND WEIGHT OF A PALLET UNIT WILL VARY SLIGHTLY DEPENDING UPON THE ACTUAL DIMENSIONS OF THE BOXES AND THE WEIGHT OF THE SPECIFIC ITEM BEING UNITIZED.
- C. THE LOAD STRAPS MAY BE THREADED THROUGH THE STRAP SLOTS OF A PALLET OR PRE-POSITIONED ON THE PALLET DECK PRIOR TO PLACING BOXES ON THE PALLET. LOAD STRAPS MUST BE TENSIONED AND SEALED PRIOR TO APPLICATION OF TIEDOWN STRAPS.
- D. INSTALL EACH TIEDOWN STRAP TO PASS UNDER THE DECK/STRINGER BOARDS OF THE PALLET AND TO BE LOCATED AS SHOWN. TIEDOWN STRAPS WILL NOT BE APPLIED UNTIL THE LOAD STRAPS HAVE BEEN TENSIONED AND SEALED.
- E. THE FOLLOWING AMC DRAWINGS ARE APPLICABLE FOR OUTLOADING AND STORAGE OF THE ITEMS COVERED BY THIS APPENDIX.
  - CARLOADING - - - - 19-48-4115-5PA1002
  - TRUCKLOADING - - - 19 48 4117 11PA1003
  - STORAGE - - - - - 19-48-4118-1-2-3-4-14-22PA1002
  - END OPENING ISO
  - CONTAINER - - - - 19-48-4153-15PA1002
  - MILVAN - - - - - 19-48-4166-15PA1003
  - SIDE OPENING ISO
  - CONTAINER - - - - 19-48-4267-15PA1009
- F. FOR METHOD OF SECURING A STRAP CUTTER TO THE PALLET UNIT, SEE AMC DRAWING 19 48 4127 20P1000.
- G. IF ITEMS COVERED HEREIN ARE UNITIZED PRIOR TO ISSUANCE OF THIS APPENDIX, THE BOXES NEED NOT BE REUNITIZED SOLELY TO CONFORM TO THIS APPENDIX.
- H. THE UNITIZATION PROCEDURES DEPICTED HEREIN MAY ALSO BE USED FOR UNITIZING SIMULATORS WHEN IDENTIFIED BY DIFFERENT NATIONAL STOCK NUMBERS (NSN) THAN WHAT IS SHOWN ON PAGE 2, PROVIDED THE BOX PACK DOES NOT VARY FROM WHAT IS DELINEATED HEREIN. THE EXPLOSIVE CLASSIFICATION OF OTHER ITEMS MAY BE DIFFERENT THAN WHAT IS SHOWN.
- J. THE 63-1/4" WIDTH DIMENSION IS AN EXCEPTION TO THE BASIC PROCEDURES. HOWEVER, THIS EXCEPTION IS NECESSARY FOR THE AMMUNITION PACK COVERED IN THIS APPENDIX, TO MOST EFFECTIVELY GET AN ACCEPTABLE, COMPACT AND SOUND PALLET UNIT.
- K. THE STYLE 1B PALLET DELINEATED IN THE DETAIL AT LEFT NEED NOT HAVE CHAMFERS OR STRAP SLOTS AS SPECIFIED WITHIN MILITARY SPECIFICATION MIL-P-15011 WHEN USED FOR THE UNITIZATION OF ITEMS COVERED BY THIS APPENDIX.

**PALLET UNIT**

SEE GENERAL NOTE "B" AT RIGHT.

12 BOXES OF SIMULATORS (162 PER BOX) AT 93 LBS	- - - - -	1,116 LBS (APPROX)
DUNNAGE	- - - - -	6 LBS
PALLET	- - - - -	90 LBS
<hr/>		
TOTAL WEIGHT	- - - - -	1,212 LBS (APPROX)
CUBE	- - - - -	60.0 CU FT (APPROX)

BILL OF MATERIAL			
PALLET, 42" X 53"	- - - - -	1 REQD	- - - - - 90 LBS
STEEL STRAPPING, 3/4"	- 75.08'	REQD	- - - - - 5.36 LBS
SEAL FOR 3/4" STRAPPING	- - 5 REQD	- - - - -	- - - - - NIL

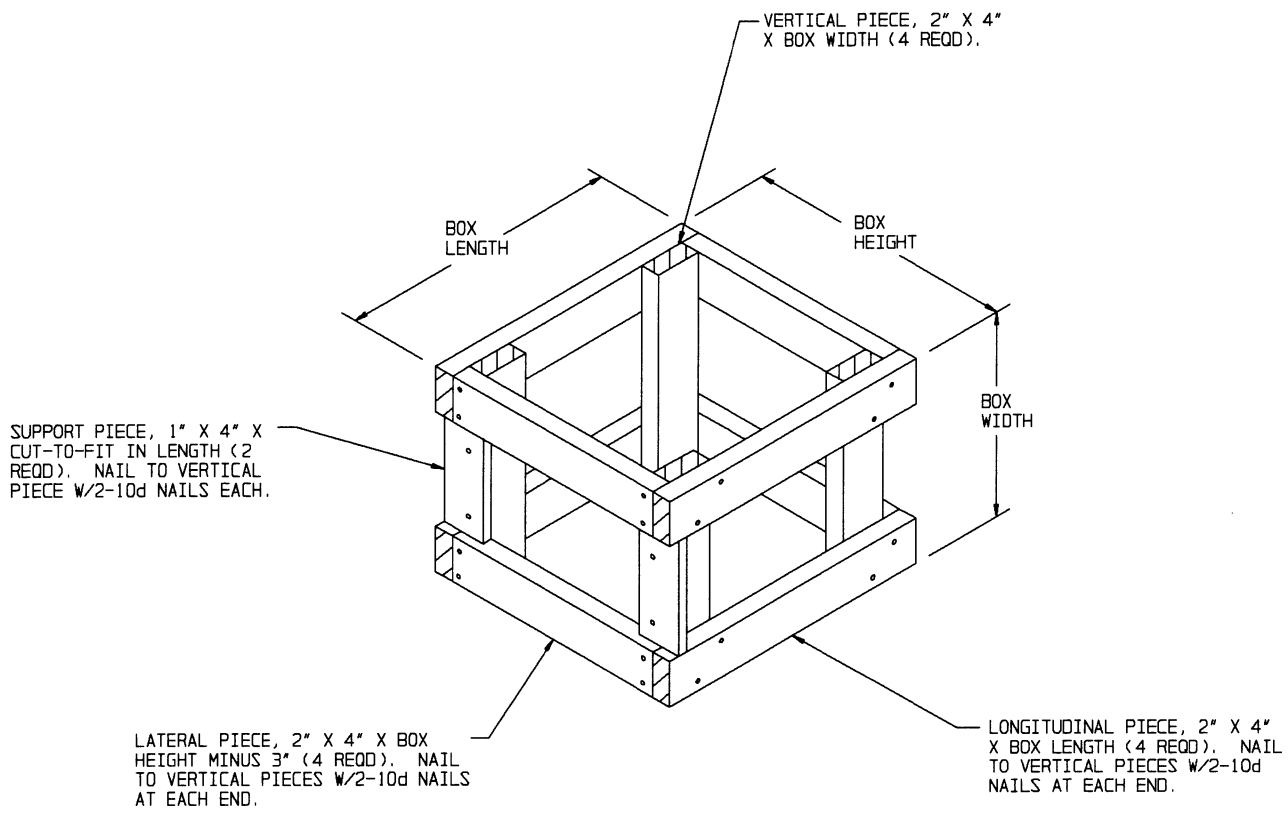

**FILLER ASSEMBLY**  
 (FOR MINUS ONE BOX)